

# SIEMENS

## SIMATIC TI545/TI555

### System Manual

Order Number: PPX:545/555-8101-2  
Manual Assembly Number: 2586546-0084  
Second Edition

**Copyright 1994 by Siemens Industrial Automation, Inc.  
All Rights Reserved — Printed in USA**

Reproduction, transmission or use of this document or contents is not permitted without express consent of Siemens Industrial Automation, Inc. All rights, including rights created by patent grant or registration of a utility model or design, are reserved.

Since Siemens Industrial Automation, Inc. does not possess full access to data concerning all of the uses and applications of customer's products, we do not assume responsibility either for customer product design or for any infringements of patents or rights of others which may result from our assistance.

Technical data is subject to change.

We check the contents of every manual for accuracy at the time it is approved for printing; however, there may be undetected errors. Any errors found will be corrected in subsequent editions. Any suggestions for improvement are welcomed.

## MANUAL PUBLICATION HISTORY

SIMATIC TI545/TI555 System Manual

Order Manual Number: PPX:545/555-8101-2

*Refer to this history in all correspondence and/or discussion about this manual.*

---

<b>Event</b>	<b>Date</b>	<b>Description</b>
Original Issue	02/93	Original Issue (2801030-0001)
Second Edition	10/94	Second Edition (2801030-0002)

---

## LIST OF EFFECTIVE PAGES

---

Pages	Description	Pages	Description
Cover/Copyright	Second		
History/Effective Pages	Second		
iii — xii	Second		
1-1 — 1-8	Second		
2-1 — 2-15	Second		
3-1 — 3-21	Second		
4-1 — 4-20	Second		
5-1 — 5-10	Second		
6-1 — 6-5	Second		
7-1 — 7-16	Second		
A-1 — A-4	Second		
B-1 — B-4	Second		
C-1 — C-4	Second		
D-1 — D-13	Second		
Index-1 — Index-4	Second		
Registration	Second		

# Contents

---

## Preface

## Chapter 1 System Overview

<b>1.1</b>	<b>Features</b> .....	<b>1-2</b>
<b>1.2</b>	<b>Hardware Description</b> .....	<b>1-6</b>
	Series 505 Base Assemblies .....	1-6
	Local and Remote I/O .....	1-6
	Series 505 Power Supply .....	1-6
	Communication Ports .....	1-7
	I/O Port .....	1-7
	Battery Backup .....	1-7
	Real-time Clock .....	1-8
	Programming Software .....	1-8
	Program Storage in EEPROM .....	1-8
	Program Storage in EPROM .....	1-8

## Chapter 2 Pre-installation Guidelines

<b>2.1</b>	<b>Planning Your Installation</b> .....	<b>2-2</b>
	Defining Control .....	2-2
	Calculating Power Needs .....	2-2
<b>2.2</b>	<b>Safety Considerations</b> .....	<b>2-3</b>
	Operator Safety Switches .....	2-4
	Emergency Stop Switch .....	2-4
	JOG or INCH Switch .....	2-5
<b>2.3</b>	<b>Enclosure and Temperature Considerations</b> .....	<b>2-6</b>
	Enclosure Selection .....	2-6
	Temperature Considerations .....	2-6
<b>2.4</b>	<b>Guidelines for Fuses/Circuit Breakers</b> .....	<b>2-7</b>
	Fusing the Controller and Remote I/O Base .....	2-7
<b>2.5</b>	<b>Definition and Source of Electrical Noise</b> .....	<b>2-8</b>
	Electrical Noise .....	2-8
<b>2.6</b>	<b>Correcting Noise Problems</b> .....	<b>2-9</b>
	Noise Snubbing .....	2-9
	Noise Isolation .....	2-11
<b>2.7</b>	<b>Wiring Considerations</b> .....	<b>2-12</b>
	Guidelines .....	2-12

---

<b>2.8</b>	<b>Power System Grounding</b> .....	<b>2-13</b>
	Earth Ground .....	2-13
	Grounding the Controller .....	2-14
	Grounding the Cabinet or Rack .....	2-14
	Ground Connections .....	2-14

## Chapter 3 Installing Series 505 System Hardware

<b>3.1</b>	<b>Overview of Installation Procedures</b> .....	<b>3-2</b>
<b>3.2</b>	<b>Series 505 Bases</b> .....	<b>3-3</b>
	Description .....	3-3
	Connecting Series 500 Bases .....	3-3
<b>3.3</b>	<b>Rack Mounting Series 505 Base</b> .....	<b>3-4</b>
	PPX:505-6516, 16-Slot Base .....	3-4
<b>3.4</b>	<b>Panel Mounting Series 505 Bases</b> .....	<b>3-5</b>
	Series 505 Bases PPX:505-6516, PPX:505-6508, PPX:505-6504 .....	3-5
<b>3.5</b>	<b>Installing Series 505 Power Supply</b> .....	<b>3-9</b>
	Power Budget for Series 505 Base .....	3-9
	Power Supply Placement in Bases .....	3-9
	Installing and Removing the Power Supply .....	3-9
<b>3.6</b>	<b>Installing the TI545/TI555 CPU</b> .....	<b>3-11</b>
	CPU/RBC Location in a Base .....	3-11
	Installing and Removing the CPU .....	3-12
	CPU Battery .....	3-13
	Setting CPU Dipswitches .....	3-13
	Using Port 1 .....	3-14
	Using Port 2 .....	3-14
	Setting Baud Rates .....	3-15
	Enabling Battery Backup .....	3-15
<b>3.7</b>	<b>Installing Series 505 Remote Base Controller</b> .....	<b>3-16</b>
	RBC Placement in Bases .....	3-16
	Dipswitches .....	3-16
	Setting RS-232 Port Baud Rates (SW 2) .....	3-16
	Series 505 RBC SW 3 (Factory) Dipswitch Settings .....	3-17
	Output State Selection .....	3-17
	Installing and Removing Series 505 RBC .....	3-19
	Assigning RBC Base Numbers .....	3-19
	Series 505 RBC LED Display .....	3-20
<b>3.8</b>	<b>Installing Series 505 I/O Modules</b> .....	<b>3-21</b>
	Mixing I/O Modules .....	3-21
	Installing and Removing I/O Modules .....	3-21

---

## Chapter 4 Cabling and Wiring the System

<b>4.1</b>	<b>Connecting Input Power</b> .....	<b>4-2</b>
	Guidelines .....	4-2
	Wiring Power Supply .....	4-2
<b>4.2</b>	<b>Cable Routing</b> .....	<b>4-4</b>
	Guidelines .....	4-4
	Cable Routing Methods .....	4-4
	Under-Floor Routing .....	4-5
	In-Ceiling Routing .....	4-5
	Surface Duct Routing .....	4-5
	Mounting the Tap or Terminal Block .....	4-5
<b>4.3</b>	<b>Installing Remote I/O Cables</b> .....	<b>4-6</b>
	Cabling Options .....	4-6
	Trunk and Drop Lines .....	4-6
	User-Supplied Equipment .....	4-7
	Mounting the Terminal Block .....	4-7
	Programmable Controller and RBC Drop Lines .....	4-7
	Preparing Cables (for Drop Lines) .....	4-8
	Connecting a CPU Drop Line .....	4-9
	Connecting the RBC Drop Line .....	4-11
	Connecting Terminal Block Trunk Lines .....	4-12
	Alternate Cables .....	4-13
	Configuration Requirements .....	4-14
	Preparing Trunk Line Cables .....	4-16
	Connecting Trunk Line to Terminal Blocks .....	4-17
<b>4.4</b>	<b>Connecting Modems</b> .....	<b>4-18</b>
	Overview .....	4-18
	Dedicated Line Operation .....	4-19
	Dial-up Phone Line Operation .....	4-19
<b>4.5</b>	<b>Connecting a Printer</b> .....	<b>4-20</b>
	Overview .....	4-20

## Chapter 5 Using an EEPROM or EPROM

<b>5.1</b>	<b>Introduction</b> .....	<b>5-2</b>
	Program Storage .....	5-2
	Using an EEPROM .....	5-2
	Using an EPROM .....	5-3
	EEPROM Functions .....	5-4
<b>5.2</b>	<b>TI545/TI555 Memory and Mode Status at Power-up</b> .....	<b>5-5</b>
<b>5.3</b>	<b>Installing EEPROMs and EPROMs</b> .....	<b>5-6</b>
<b>5.4</b>	<b>Copying a Program into an EEPROM</b> .....	<b>5-8</b>
<b>5.5</b>	<b>Editing a Program Stored in EEPROM</b> .....	<b>5-10</b>

---

## Chapter 6 Starting Up the TI545/TI555 System

<b>6.1</b>	<b>Powering Up the TI545/TI555 System</b> .....	<b>6-2</b>
	Overview .....	6-2
	Start-up Procedures .....	6-2
<b>6.2</b>	<b>TI545 CPU Memory Configuration</b> .....	<b>6-4</b>
	Memory Configuration .....	6-4
	Maximum Configurable Memory .....	6-4
<b>6.3</b>	<b>TI555 CPU Memory Configuration</b> .....	<b>6-5</b>
	Memory Configuration .....	6-5
	Maximum Configurable Memory .....	6-5

## Chapter 7 Troubleshooting

<b>7.1</b>	<b>Troubleshooting by Using Auxiliary Functions</b> .....	<b>7-2</b>
	Overview .....	7-2
	Power-up Restart, Partial Restart, and Complete Restart .....	7-2
	Compare PLC to Disk .....	7-4
	Run PLC Diagnostics .....	7-4
	Display Failed I/O .....	7-4
	Show PLC Diagnostic Cell .....	7-4
<b>7.2</b>	<b>Troubleshooting by Reading LEDs</b> .....	<b>7-6</b>
<b>7.3</b>	<b>Troubleshooting Controller Fatal Errors</b> .....	<b>7-7</b>
	CPU Fatal Error Indications .....	7-7
	Causes of CPU Fatal Errors .....	7-7
	Controller Responses to Fatal Errors .....	7-7
	Steps to Clear Fatal Errors .....	7-8
	Calling for Assistance .....	7-8
<b>7.4</b>	<b>Troubleshooting Controller Non-Fatal Errors</b> .....	<b>7-9</b>
<b>7.5</b>	<b>Troubleshooting by Using Status Words</b> .....	<b>7-10</b>
<b>7.6</b>	<b>Troubleshooting EEPROMs or EPROMs</b> .....	<b>7-11</b>
<b>7.7</b>	<b>Troubleshooting the Power Supply</b> .....	<b>7-12</b>
<b>7.8</b>	<b>Checking RS-485 (Twisted Pair) Cable Installation</b> .....	<b>7-14</b>
	Using Digital or Analog Meter .....	7-14
	Resistance Below Minimum .....	7-15
	Resistance Above Maximum .....	7-15
<b>7.9</b>	<b>Recommended Spare Parts List</b> .....	<b>7-16</b>



---

## Appendix A System Specifications

A.1	Series 505 System Specifications .....	A-2
-----	--	-----

## Appendix B Module Power Consumption

B.1	Series 505 Modules .....	B-2
-----	--------------------------	-----

## Appendix C TI545/TI555 CPU and I/O Compatibility

C.1	I/O Module Compatibility .....	C-2
	I/O Modules not Compatible with TI545/TI555 CPUs .....	C-2
	Determining the Compatibility of a Module .....	C-3
	Series 505 High Speed Counter .....	C-3
C.2	Reading the Serial Numbers .....	C-4
	Determining the Manufacturing Date .....	C-4
	Examples .....	C-4
	86ML8712020175_ .....	C-4
	86ML8712020175G .....	C-4
	86ML8801041324_ .....	C-4

## Appendix D Upgrading Series 500 Installations

D.1	Series 500 System Installations .....	D-2
D.2	Upgrading a TI520/TI520C/TI530/TI530C/TI530T System .....	D-3
	Install RS-485 Twin Axial Cabling .....	D-3
	Check Base to be Upgraded .....	D-4
	Upgrading 14-Slot, 12-Slot, 6-Slot Bases .....	D-4
	Upgrading 16-Slot and 8-Slot Bases .....	D-4
	Finish Upgrade with these Steps .....	D-4
D.3	Upgrading an RS-485 Based TI560/TI565/TI560T/TI565P System .....	D-6
D.4	Upgrading an RF Based TI560/TI565/TI560T/TI565P System .....	D-8
D.5	Installing a PPX:500-5114A RBC .....	D-10
	Output State Selection .....	D-10
	Installing a Series 500 RBC .....	D-11
	Setting Baud Rates .....	D-12
	Assigning Base Numbers .....	D-12
	Series 500 RBC LED Display .....	D-13

## List of Figures

---

Figure 1-1	Typical TI555-1102 Control System	1-4
Figure 1-2	TI545/TI555 System Using Series 500 and Series 505 Components	1-5
Figure 2-1	Operator Safety Switch	2-4
Figure 2-2	Emergency Stop Switch	2-4
Figure 2-3	JOG or INCH Switch	2-5
Figure 2-4	Fuse/Circuit Breaker Placement	2-7
Figure 2-5	Load Noise Snubbing	2-9
Figure 2-6	Contact Noise Snubbing	2-10
Figure 2-7	Grounding Shielded, Twisted Pair Cables	2-11
Figure 2-8	Isolating Ground and Neutral From Conduit	2-13
Figure 2-9	Grounding the TI545/TI555 Controller	2-14
Figure 2-10	Example of Ground Connection	2-15
Figure 3-1	Mounting Base to Standard 19-inch Rack	3-4
Figure 3-2	Screw-hole Dimensions for PPX:505-6516/6511 Bases	3-5
Figure 3-3	Screw-hole Dimensions for PPX:505-6504 Bases	3-6
Figure 3-4	Screw-hole Dimensions for PPX:505-6508 Bases	3-7
Figure 3-5	Mounting Brackets to Base	3-8
Figure 3-6	Mounting Base in NEMA Enclosure	3-8
Figure 3-7	Series 505 Module Placement in Base	3-9
Figure 3-8	Selecting Input Voltage—PPX:505-6660 Only	3-10
Figure 3-9	Location of CPU/RBC in a Series 505 Base	3-11
Figure 3-10	Installing CPU Module in a Series 505 Base	3-12
Figure 3-11	CPU Dipswitch Location	3-13
Figure 3-12	TI545/TI555 CPU Port Locations	3-14
Figure 3-13	RBC Dipswitch Location	3-16
Figure 3-14	Series 505 RBC Jumper Locations	3-18
Figure 3-15	Series 505 Remote Base Controller	3-20
Figure 3-16	Installing and Removing Modules in a Series 505 Base	3-21
Figure 4-1	Supplying Power with the PPX:505-6660A	4-3
Figure 4-2	Trunk and Drop Line Example	4-6
Figure 4-3	9-Pin I/O Female D-Connector Pinout	4-8
Figure 4-4	Connecting to Terminal Block	4-9
Figure 4-5	Adding a Terminating Resistor	4-10
Figure 4-6	Attaching RBC to Terminal Block	4-11
Figure 4-7	Maximum Trunk Length	4-14
Figure 4-8	T Configuration	4-14
Figure 4-9	Multiple Tap Connections in Close Proximity	4-15
Figure 4-10	Spacing between Taps	4-15
Figure 4-11	Connecting Terminal Blocks	4-17
Figure 4-12	Modem Configuration	4-18

---

Figure 4-13	XON/XOFF Printer Handshaking	4-20
Figure 4-14	READY/BUSY Printer Handshaking	4-20
Figure 5-1	EEPROM (EPROM) Socket and Jumper Pins	5-7
Figure 7-1	Typical AUX Function 29 Screen	7-5
Figure 7-2	Replacing PPX:505–6660 Power Supply Fuse	7-13
Figure C-1	Serial Number Definition	C-4
Figure D-1	Upgrading a TI520/TI520C/TI530/TI530C/TI530T System	D-5
Figure D-2	Upgrading an RS-485 Based TI560/TI565/TI560T/TI565P System	D-7
Figure D-3	Upgrading an RF Based TI560/TI565/TI560T/TI565P System	D-9
Figure D-4	Series 500 RBC Switch Selection	D-10
Figure D-5	Installed Series 500 RBC	D-11
Figure D-6	Series 500 Remote Base Controller and Baud Rate Settings	D-12

## List of Tables

---

Table 1-1	TI545/TI555 Capacity/Performance .....	1-2
Table 1-2	Program Storage Using EEPROM and EPROM .....	1-8
Table 3-1	Base Assembly Models .....	3-3
Table 3-2	Port 1 Baud Rate Settings .....	3-15
Table 3-3	Port 2 Baud Rate Settings .....	3-15
Table 3-4	RBC SW 2 (RS-232 Port) Baud Rate Settings .....	3-16
Table 3-5	Series 505 RBC SW 3 (Factory) Dipswitch Setting .....	3-17
Table 3-6	Series 505 RBC LED Messages .....	3-20
Table 4-1	Terminating Resistors .....	4-10
Table 4-2	Maximum Cable Length for Trunk Lines .....	4-12
Table 4-3	Cable Characteristics .....	4-13
Table 5-1	Program Storage Using EEPROM and EPROM .....	5-2
Table 5-2	EEPROM/EPROM Portability Between Controllers .....	5-2
Table 5-3	TI545/TI555 Mode and Memory Status After Power-up .....	5-5
Table 6-1	TI545-1102 CPU Memory Configuration .....	6-4
Table 6-2	TI555-1101/1102 CPU Memory Configuration .....	6-5
Table 7-1	Effects of Using AUX Functions 10, 11, and 12 .....	7-3
Table 7-2	CPU Indicators .....	7-6
Table 7-3	Cable Resistance .....	7-14
Table A-1	Environmental Specifications .....	A-2
Table A-2	General Series 505 Specifications .....	A-3
Table A-3	Power Supply Electrical Specifications .....	A-4
Table B-1	Series 505 Module Power Requirements .....	B-2
Table D-1	Base Numbers .....	D-13
Table D-2	Series 500 RBC LED Messages .....	D-13

# Preface

---

## About this Manual

This *SIMATIC*<sup>®</sup> *TI545*<sup>™</sup> / *TI555*<sup>™</sup> *System Manual* includes requirements and specifications for preparing your control site and installing a SIMATIC TI545/TI555 Programmable Logic Controller (PLC) system.

---

**NOTE:** This manual describes the SIMATIC TI545-1102 CPU, and both the SIMATIC TI555-1101 and -1102 CPUs. Information in this manual does not apply to the SIMATIC TI545-1101 CPU. For the information concerning the SIMATIC TI545-1101 CPU refer to *SIMATIC TI545 System Manual*: PPX:545-8101-x.

---

The following major topics are covered.

- Site preparation including power and grounding requirements and other safety considerations.
- Hardware installation including Series 505<sup>™</sup> bases, power supplies, TI545/TI555 CPUs, Remote Base Controllers (RBCs), and I/O modules.
- Upgrade of Series 500<sup>™</sup> bases for connection to the TI545/TI555.
- System cable and wiring procedures.
- Using EEPROMs or EPROMs.
- System startup, including modem operation.
- System troubleshooting, including use of AUX functions, status words, and other diagnostic aids.
- General maintenance procedures such as changing power supply fuses.

---

## Related Manuals

Additional manuals that have relevant information include the following:

- *SIMATIC® TI505™ Programming Reference Manual (PPX:505–8104-5).*
- *SIMATIC® TI505/TI500 TISOFT™ Release 5.0 User Manual (PPX:TS505–8101-x).*
- *SIMATIC TI505 Input/Output Modules User Manual (PPX:505–8105-x).*
- *SIMATIC TI505 Analog I/O Modules User Manual (PPX:505–8120-x).*
- *SIMATIC TI505 H1 Communication Processor User Manual (PPX:505–8126–2 or later).*
- *SIMATIC TI505 Redundant I/O Systems Users Manual, (PPX:505-8125-x).*
- *SIMATIC TI505 Isolated Interrupt Discrete Input Module User Manual (PPX:505-4317–x) provides information on configuring and installing the Interrupt Input module (PPX:505–8123-x) which is required for the operation of interrupt I/O.*

Refer to material in these manuals as necessary for additional information about programming and operating your TI545/TI555 system.

## Agency Standards

Series 505 products have been developed with consideration of the draft standard of the International Electrotechnical Commission Committee proposed standard (IEC-65A/WG6) for programmable controllers (released as IEC 1131–2, Programmable Controllers Part 2: Equipment Requirements and Tests, First Edition, 1992–09). Contact Siemens Industrial Automation, Inc., for information about regulatory agency approvals that have been obtained on the TI545/555 systems and Series 505 units.

Agency Approvals are the following:

- UL Listed (industrial control equipment)
- CSA Certified (process control equipment)
- FM (Class I, Div. 2, Group A, B, C, D Hazardous Locations)

## Technical Assistance

For technical assistance, contact your Siemens Industrial Automation, Inc. distributor or sales office. If you need assistance in contacting your sales agent or distributor in the United States, call 1–800–964–4114.

# Chapter 1

## System Overview

---

### Chapter 1 System Overview

<b>1.1</b>	<b>Features</b> .....	<b>1-2</b>
<b>1.2</b>	<b>Hardware Description</b> .....	<b>1-6</b>
	Series 505 Base Assemblies .....	1-6
	Local and Remote I/O .....	1-6
	Series 505 Power Supply .....	1-6
	Communication Ports .....	1-7
	I/O Port .....	1-7
	Battery Backup .....	1-7
	Real-time Clock .....	1-8
	Programming Software .....	1-8
	Program Storage in EEPROM .....	1-8
	Program Storage in EPROM .....	1-8

## 1.1 Features

---

The TI545/TI555 CPUs and support equipment comprise a computer-controlled system that is capable of controlling complex manufacturing systems. This system performs the same functions as relays, static control, or card logic control systems. It can detect the change in state of input signals from such devices as pushbuttons, limit switches, and analog sensors.

Acting on this information and executing a Relay Ladder Logic (RLL) program stored in memory, the TI545/TI555 CPU produces output signals to drive motor starters, solenoids, pilot lights, modulating control valves, etc. These signals are used to regulate the operation of various pieces of equipment.

### Features

The TI545/TI555 systems offer the following features:

- Memory and I/O capacities and scan performance are summarized in Table 1-1.

Table 1-1 TI545/TI555 Capacity/Performance

Feature	TI545	TI555	
	-1102	-1101	-1102
User Memory (bytes)	192K	384K	1920K
EEPROM (EPROM) (bytes)	256K		
Discrete I/O Points	2048 <sup>1</sup>	8192 <sup>2</sup>	
Word I/O Points	1024 <sup>1</sup>		
Control Relays	32,768		
Scan Performance (milliseconds/KW, best case)	.67	.07	
Notes: <sup>1</sup> Total I/O count may not exceed 2,048 points. <sup>2</sup> Total I/O count may not exceed 8,192 points.			

- Optional password protection for user programs.
- Support for Report By Exception (RBE) when used as a control element in a SIMATIC® PCS™ System (Release 3.0 or later).



- 
- Interrupt I/O allows for fast reaction to external events.
  - Support for Redundant Remote Base Controller.
  - Immediate I/O Updates allow your application program to access an I/O point multiple times during a controller scan.
  - Cyclic RLL allows you to create an additional RLL program that runs independently of the main RLL program.
  - External subroutines allows your program to call externally developed programs written in high-level languages such as C.
  - Proportional-Integral-Derivative (PID) loop functions for process and batch control.
  - Special Function Programs (SFPGMs) and Special Function Subroutines (SFSUBs) that use a higher level statement-driven programming language to ease the development of complex programs.
  - Up to 256 SF modules can be used in the TI545/TI555 system.
  - A communication port baud rate of up to 19,200 baud to provide fast communication with your (programming) operator interfaces.
  - Ethernet connectivity using H1 protocol and the CP1434TF H1 module (Rel. 2.0 and later).
  - Adjustable processor scan time by using the configurable timeline function.
  - Analog alarm functionality.
  - Non-volatile program storage and execution (EEPROM or EPROM).
  - Series 505 footprint.

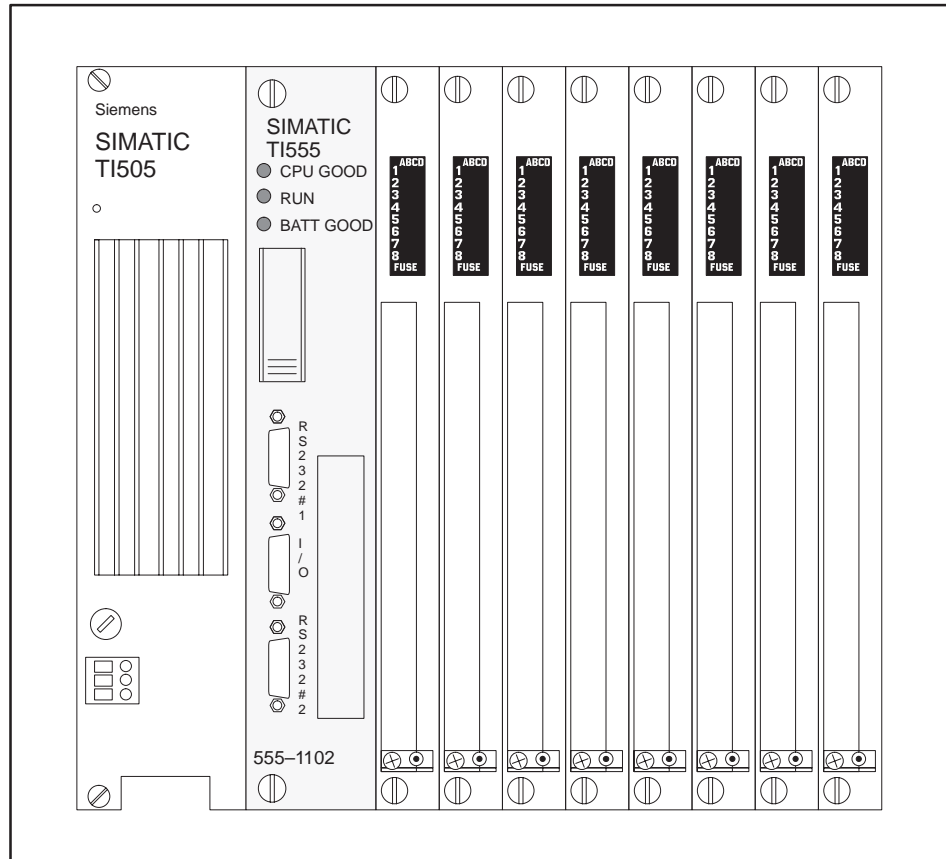

Figure 1-1 Typical TI555-1102 Control System

TI545/TI555 systems (see Figure 1-1) are designed for use in applications that require discrete and analog control. Components include the CPU and the support devices that provide operator communication, I/O control, and power (see Figure 1-2).

You can communicate with the CPU by using the following devices:

- IBM® PC/AT® (386 or higher) or a 100% compatible computer, using the SIMATIC® APT™ or TISOFT software.
- Control Vision Unit (CVU100™, CVU1000™, or CVU10000™).
- SIMATIC PCS.

The TI545/TI555 controller system uses individual Series 505 or Series 500 I/O modules for I/O interfaces. A full line of discrete, analog, word, and intelligent I/O modules are available for handling almost any input or output specification. These I/O modules are rugged, plug-in devices capable of functioning in harsh environments within the operating specifications.

The controllers can also communicate with other devices through the SINEC® H1 or SIMATIC® TIWAY™ Local Area Networks. See documents listed in the Preface of this manual for information on these systems.

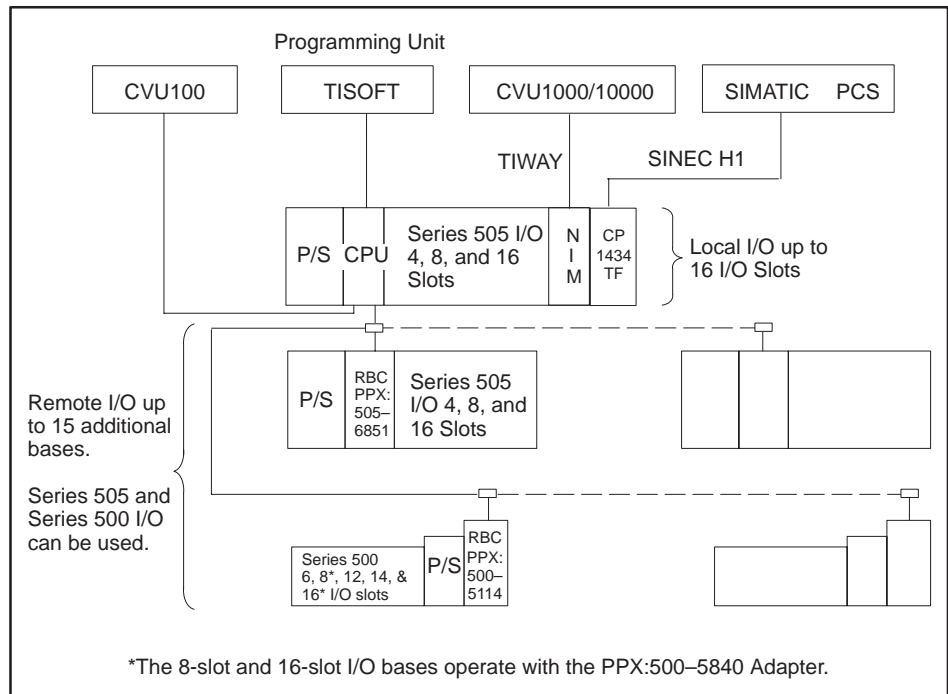

Figure 1-2 TI545/TI555 System Using Series 500 and Series 505 Components

## 1.2 Hardware Description

---

### Series 505 Base Assemblies

The CPUs are housed in a Series 505 base assembly. A base assembly has slots for the CPU or remote base controller (RBC), a power supply, and the I/O modules. Three base assembly models are currently available. Each has the following number of slots for I/O modules.

- Model PPX:505–6504, 4 slots.
- Model PPX:505–6508, 8 slots.
- Model PPX:505–6511, 11 slots (redundant). Power supply and media.
- Model PPX:505–6516, 16 slots.

Any base assembly may be used at any point in the system, depending upon the number of I/O points required.

### Local and Remote I/O

I/O modules are grouped into local and remote I/O categories depending upon their physical location. The local I/O comprises those modules located in the same base assembly as the CPU. If you install the CPU in base assembly Model PPX:505–6516, the local I/O may consist of as many as 16 I/O modules. The base assembly containing the local I/O is designated 0.

You can connect up to 15 additional base assemblies to the system, numbered 1–15. The I/O modules in these bases make up the remote I/O as shown in Figure 1-2.

Individual I/O modules in the remote bases communicate with the CPU through RBCs. The RBC in each remote base transmits information from the I/O modules in that base directly to the CPU.

### Series 505 Power Supply

The power supply provides up to 55 W at +5 VDC and 3.75 W at –5 VDC for use by the CPU and the I/O modules. The PPX:505–6660 power supply operates at either 110 VAC or 220 VAC on user-supplied power. A jumper on the inside of the back of the module is used to select voltage. The model PPX:505–6663 power supply operates on 24 VDC user-supplied power.

---

Communication  
Ports

The CPU has two communications ports; features and descriptions are listed below. Both ports are configured as Data Terminal Equipment (DTE).

- **Port 1** — RS-232 (9-pin male) is used to either program the CPU by an IBM PC/AT compatible computer with APT or TISOFT, or to attach equipment such as the Timer/Counter Access Module (TCAM), a CVU100, or other operator interface using RS-232. The operator interface can be up to 50 feet (15 m) away. A user supplied modem can be used to extend this distance. Port 1 can also be used to attach a printer.
- **Port 2** — RS-232/RS-423 or RS-422/RS-485 (9-pin male) is used to communicate with operator interface equipment. Selection between RS-232/423 and RS-422/485 is done with cabling options. Dipswitch 1 selects between RS-422 and RS-485 if 422/485 cabling is used. See Chapter 3, Making Port Selection. Distance constraints are listed below.
  - RS-232/RS-423 connection for operator interface up to 50 feet.
  - RS-422/RS-485 connection to 1000 feet.

I/O Port

The CPU has one Remote I/O port, (9-pin female) used to communicate directly with remote base controllers (RBCs). This port uses a twisted, shielded-pair RS-485 cable to communicate with RBCs.

Both Series 505 (see NOTE and Appendix C) and Series 500 I/O modules can be connected to the TI545/TI555 CPU as remote I/O. The CPU is capable of directly addressing the PPX:505-6851-A RBC in a Series 505 base assembly, or the PPX:500-5114-A RBC in a Series 500 base assembly intermixed in the same system. Both RBC models use shielded twisted-pair cable. They can be placed up to 3300 feet from the CPU.

---

NOTE: You cannot use some early model Series 505 I/O modules with a TI545/TI555 CPU. Refer to Appendix C for details.

---

Battery Backup

A permanent, rechargeable battery protects user memory and programming during a power outage. Battery memory backup typically lasts six months at temperatures ranging from 0° to 60°C.

 CAUTION

**Battery Damage: If the TI545/TI555 unit is left without power and with the battery switch on for longer than six months, the battery may be damaged to the point that it cannot be recharged.**

**Be aware that the battery will appear to charge, but the memory backup time will be seriously degraded.**

**Return a unit in this condition to the factory for battery replacement.**

---

## Hardware Description (continued)

---

### Real-time Clock

The CPU contains a real-time clock which includes the following information:

- Year (two digits), Month, Day of month, and Day of week.
- Hour, minute, second, tenths and hundredths of a second.

### Programming Software

You can use APT to program the CPU. APT is a graphic programming environment that eliminates the need for you to work in relay ladder logic when you create your application program. APT presents a familiar structure for process engineers, allowing them to become more closely involved in up-front design work. When the APT program is compiled, an RLL program code is produced, generating the language with which the electrician or maintenance person is already familiar. Refer to the APT manual set for more information.

You can use the TISOFT programming software to create and edit your application program. TISOFT allows you to work directly in the ladder logic environment as you design the RLL program. For loops, analog alarms, and SF programs, TISOFT presents menu-driven programming tools.

To program the latest features that are described in the Preface of this manual, you need TISOFT Release 5.0, which runs on an IBM PC/AT (386 or higher) compatible personal computer running MS-DOS® 3.3 or later.

Refer to your TISOFT manual for detailed instructions about how to enter a program.

### Program Storage in EEPROM

The CPU offers the option of saving your RLL program in a non-volatile form by downloading it to an EEPROM integrated circuit as shown in Table 1-2. A separate programming device is not necessary. Once programmed, an EEPROM can be removed and used in any Release 3.0 or higher CPU as required. To help ensure equipment compatibility, use only the EEPROM model supplied by your distributor.

### Program Storage in EPROM

If your operating program does not change, you can store it permanently on EPROM(s) as shown in Table 1-2. By copying your program from an EEPROM to an EPROM (using an EPROM copier), you can create additional copies for CPUs that are running the same program.

Table 1-2 Program Storage Using EEPROM and EPROM

Storage Type	Size	Order Number
EEPROM	128K bytes	2587681-8022
EEPROM	256K bytes	2587681-8030
EPROM	128K bytes	2587681-8023
EPROM	256K bytes	2587681-8031

# Chapter 2

## Pre-installation Guidelines

---

### Chapter 2 Pre-installation Guidelines

<b>2.1</b>	<b>Planning Your Installation</b> .....	<b>2-2</b>
	Defining Control .....	2-2
	Calculating Power Needs .....	2-2
<b>2.2</b>	<b>Safety Considerations</b> .....	<b>2-3</b>
	Operator Safety Switches .....	2-4
	Emergency Stop Switch .....	2-4
	JOG or INCH Switch .....	2-5
<b>2.3</b>	<b>Enclosure and Temperature Considerations</b> .....	<b>2-6</b>
	Enclosure Selection .....	2-6
	Temperature Considerations .....	2-6
<b>2.4</b>	<b>Guidelines for Fuses/Circuit Breakers</b> .....	<b>2-7</b>
	Fusing the Controller and Remote I/O Base .....	2-7
<b>2.5</b>	<b>Definition and Source of Electrical Noise</b> .....	<b>2-8</b>
	Electrical Noise .....	2-8
<b>2.6</b>	<b>Correcting Noise Problems</b> .....	<b>2-9</b>
	Noise Snubbing .....	2-9
	Noise Isolation .....	2-11
<b>2.7</b>	<b>Wiring Considerations</b> .....	<b>2-12</b>
	Guidelines .....	2-12
<b>2.8</b>	<b>Power System Grounding</b> .....	<b>2-13</b>
	Earth Ground .....	2-13
	Grounding the Controller .....	2-14
	Grounding the Cabinet or Rack .....	2-14
	Ground Connections .....	2-14

## 2.1 Planning Your Installation

---

Preparing the site for installation of your TI545/TI555 controller consists of the following tasks.

- Defining control requirements
- Determining the number of controllers needed
- Determining the panel and grounding layout

---

**NOTE:** Since no two applications are identical, use these recommendations as general guidelines only.

---

### Defining Control

Use the following steps to define your control requirements:

- Define the number and type of inputs and outputs you need.
- Calculate the number of I/O modules and bases that you need.
- Determine the power requirements and mounting space needed.
- Consider availability of space (including growth potential). This is particularly true if several double-wide modules are needed.

### Calculating Power Needs

Calculate a power budget for each base prior to installation. The power requirements of all modules must be included in the calculations — the controller, the base controllers, as well as the I/O modules. The user-supplied power to individual modules is not a part of the power budget calculation. Refer to Appendix B for Series 505 module power consumption information.

To help ensure reliable system operation, the total power required for the controller and I/O modules must not exceed the total power available from the system power supply. Refer to Chapter 3 for Series 505 power budget.



## 2.2 Safety Considerations

---

Pre-installation planning and site preparation must include consideration of hazards to personnel in the event of a system failure. The equipment connected to the control system must include interlocks and safety switches to help prevent operation during a system failure. Although the specific steps depend on the application, the general precautions include the following data.

### WARNING

---

**Control devices can fail in an unsafe condition. This means that, unless you incorporate proper safeguards, certain malfunctions of these devices could lead to a sudden equipment startup or shutdown. Such a startup or shutdown could result in property damage and/or death or severe physical injury to the equipment operator. Failure can also be exhibited as erratic or unexpected operation.**

**If you, or your company, use any programmable controllers with equipment which requires an operator or attendant, you should be aware that this potential safety hazard exists and take appropriate precautions. Although the specific design steps depend on your particular application, the following precautions generally apply to installation of solid-state programmable control devices.**

**These precautions conform to the guidelines for installation of Programmable Controllers as recommended in the NEMA ICS 3-304 Programmable Control Standards.**

---

### **ICS 3-304.81 Safety Recommendations:**

*Consideration should be given to the use of an emergency stop function which is independent of the programmable controller.*

*Where the operator is exposed to the machinery, such as in loading or unloading a machine tool, or where the machine cycles automatically, consideration should be given to the use of an electromechanical override or other redundant means, independent of the programmable controller, for starting and interrupting the cycle.*

*If provision is required for changing programs while the equipment is in operation, consideration should be given to the use of locks or other means of assuring that such changes can be made only by authorized personnel.*

*These recommendations are intended as safeguards against the failure of critical components and the effects of such failures or the inadvertent errors that might be introduced if programs are changed while the equipment is in operation.*

The ICS 3-304.81 Safety Recommendations from NEMA ICS 3-304, Programmable Controller Standard. Recommendations are reproduced by permission of the National Electrical Manufacturers Association.

## Safety Considerations (continued)

### Operator Safety Switches

Provide a means for disconnecting power — independent of the controller — from the output loads when a machine is not operating, or when it is necessary for the operator to reach into the machine. Power must be removed by a non-semiconductor switch or a physically-wired relay contact, placed to interrupt power to the output. It is not sufficient to rely solely on the controller for this function. Figure 2-1 shows an operator safety switch.

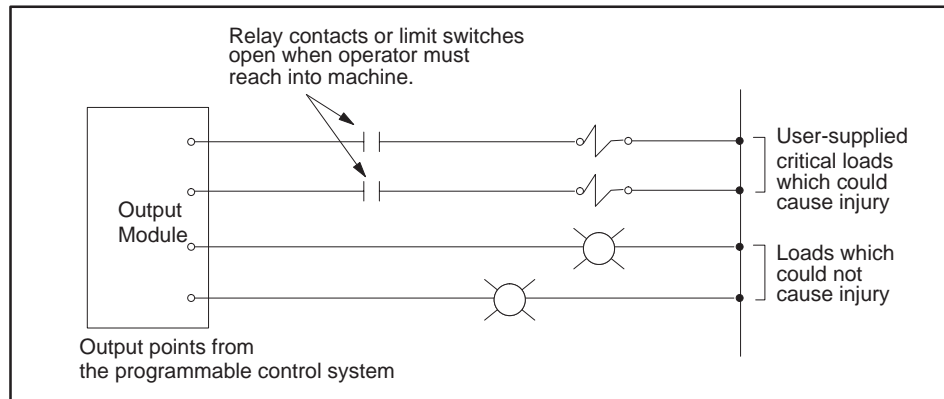

Figure 2-1 Operator Safety Switch

### Emergency Stop Switch

Provide a means for removing power from the output if an emergency condition occurs with the machine during operation. Do this by disconnecting output power with a non-semiconductor switch or hardwired relay contact, not through the programmable control system (Figure 2-2).

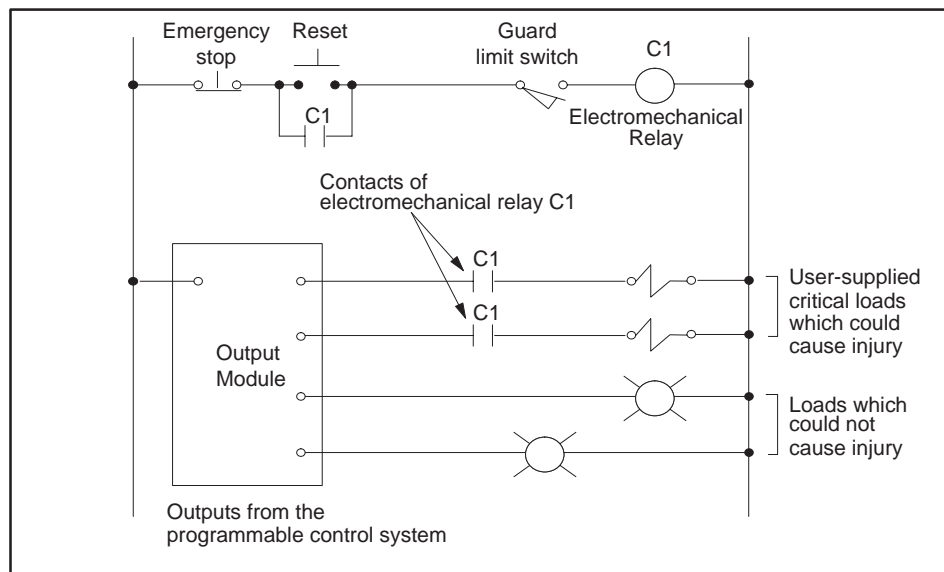
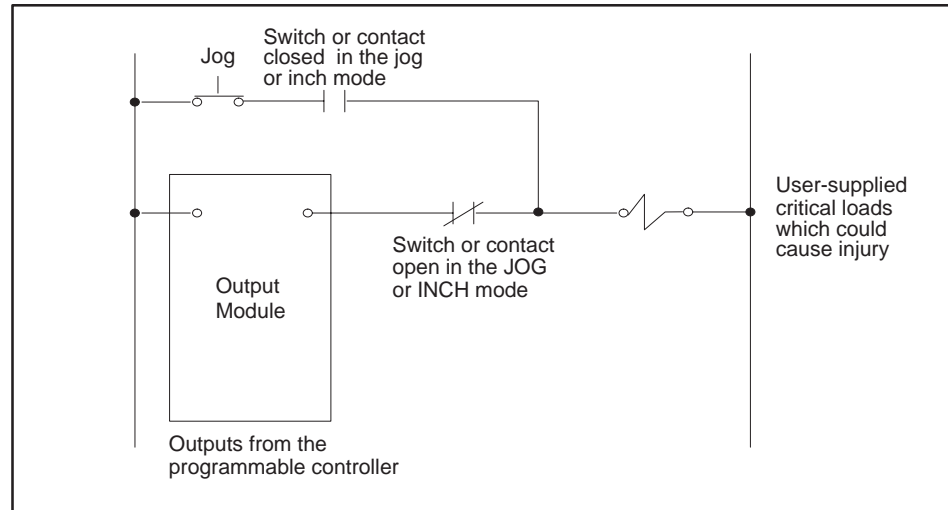

Figure 2-2 Emergency Stop Switch

**JOG or INCH  
Switch**

Bypass the programmable control system with an external JOG or INCH switch during machine loading or setup operations. See Figure 2-3.



**Figure 2-3 JOG or INCH Switch**

## 2.3 Enclosure and Temperature Considerations

---

Enclosure Selection    An enclosure should provide the following features:

- Easy access to components.
- A common ground potential on the cabinet.
- A secure vertical panel or rails.
- Conformance to electrical standards.
- An electromagnetic shield.
- Access restricted to authorized personnel only.
- Cooling and heat dissipation.
- Protection from dust and dirt as required by the environment.

Mount the components in a dustproof and drip tight enclosure such as the NEMA Type enclosure. The enclosure must provide a minimum depth of 10 in. (25.4 cm) from the panel to the inside surface of the enclosure door. The enclosure should be located so that the doors may be opened fully, permitting easy access to the controller, wiring, and components. If environmental conditions permit, a 19-inch rack may be used instead of a NEMA enclosure. Use the 16-slot PPX:505–6516 I/O base for 19-inch rack installations.

Temperature  
Considerations

When preparing your installation, plan for an adequate air flow to ensure proper cooling of equipment. Do not permit the convection cooling of the controller to be hindered. Unless ambient temperatures are extremely high, a fan or air-conditioned cooling is unnecessary for keeping controllers below their maximum-rated operating temperature of 60°C provided that the cabinet adequately dissipate heat.

For one local base and one remote base located in the bottom half of a 7-foot, 19-inch rack, place equipment that dissipates no more than 325 W in the top half, above the System 505 bases, assuming a 25°C external ambient temperature. If you must exceed these guidelines, use cooling equipment to lower the equipment temperature to the recommended level.

## 2.4 Guidelines for Fuses/Circuit Breakers

### Fusing the Controller and Remote I/O Base

Use the following guidelines for installing fuses/circuit breakers; see Figure 2-4. The sizes and types of fuses/circuit breakers depend on the specified power distribution requirement.

- A circuit breaker before isolation transformer (isolation transformers may not be required if your power distribution system does not have a high level of noise).
- A fuse after isolation transformer.
- An external fuse before each power supply.

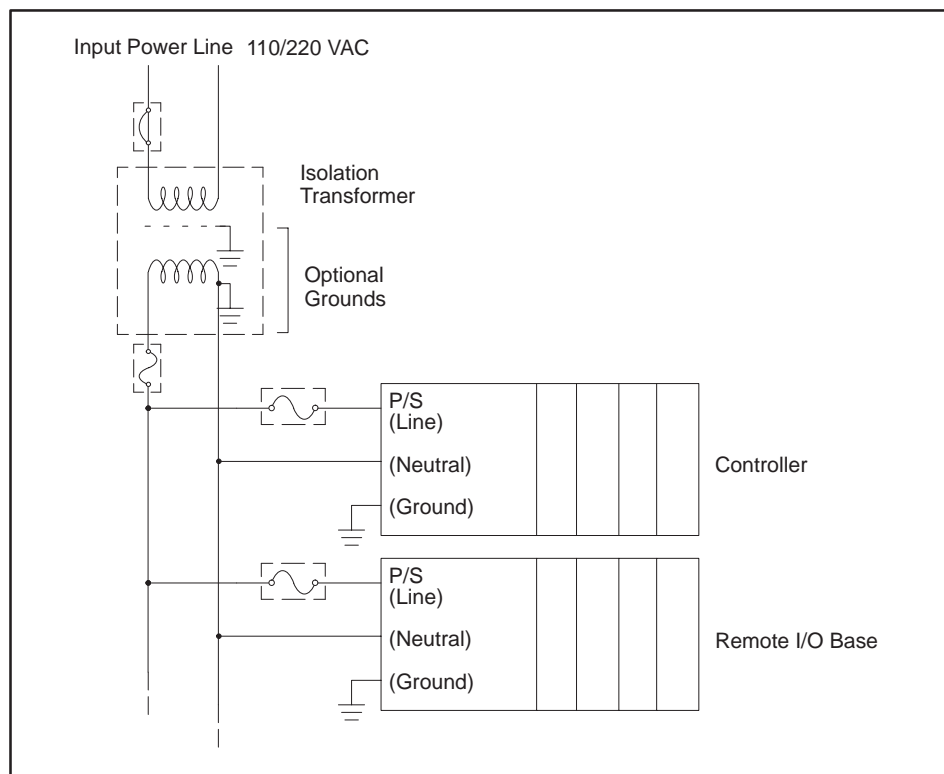

Figure 2-4 Fuse/Circuit Breaker Placement

**NOTE:** In order to ensure a proper level of safety compliance, observe local installation code practices and guidelines.

## 2.5 Definition and Source of Electrical Noise

---

### Electrical Noise

Electrical noise is defined as any unwanted electrical signal which enters the control equipment. Noise signals cover the entire spectrum of frequencies and may have any wave shape.

A major difficulty with noise problems is that they can occur at random intervals. Continuous, or frequent, periodic noises generally are easy to detect and remedy. Intermittent noise sources that produce short, high-energy bursts at irregular and widely spaced intervals create problems that can be harder to resolve.

The primary sources of noise in industry are those devices (and their wiring) that produce and switch high voltage and current. Typical examples include large motors, welders and contacts that switch heavily inductive loads such as brakes or clutches.

Noise can enter your control equipment by several routes. It can be conducted through signal or power wiring or can be radiated by electromagnetic waves. Conducted noise typically is coupled with the signal or power wiring, either electrostatically or magnetically.

Electrostatic coupling occurs through parasitic capacitance between the noisy line and the signal/power line. This requires high voltage or high rate of change voltages in the noisy line and high parasitic capacitance between lines. This can occur when you have long wire runs in the same conduit.

Magnetic coupling occurs through mutual inductances between lines. This requires high currents or high rates of change of current, as well as significant mutual inductance.

Electromagnetically radiated noise typically is high frequency (radio waves). The control system and its wiring may act as antennas in picking up noise signals. This pathway is least likely to present problem levels of noise, but its sources are common in industrial applications.

## 2.6 Correcting Noise Problems

When potential noise problem sources are identified, two general methods are available to handle them. These methods are described in the following sections.

- Noise snubbing.
- Noise isolation.

These methods are described in the following sections.

### Noise Snubbing

Noise snubbing reduces noise at its source. Applicable only to devices driven by mechanical contacts, snubbing suppresses arcing at electrical contacts caused by turnoff of inductive loads (e.g., relays, motors, motor starters, solenoids, etc.).

Load snubbing (shown in Figure 2-5) reduces voltage transients at the load, preventing them from traveling back to the contacts where they would produce a showering arc and couple with adjacent wiring.

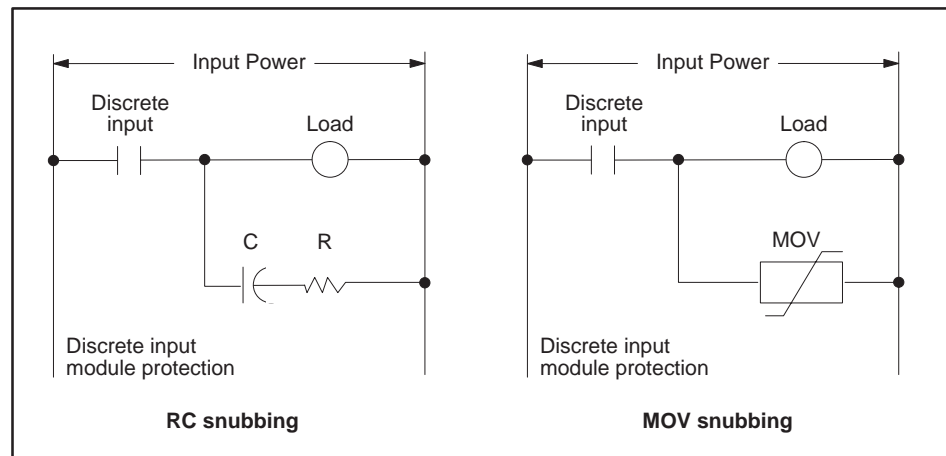

Figure 2-5 Load Noise Snubbing

## Correcting Noise Problems (continued)

---

You can also use contact snubbing (shown in Figure 2-6) as an alternative type of snubbing.

Both types of snubbing cause the physical devices to come on or go off more slowly. The resistance-capacitance (RC) and metal oxide varistor (MOV) elements should have minimal effect on system timing; their time constants are substantially less than one millisecond.

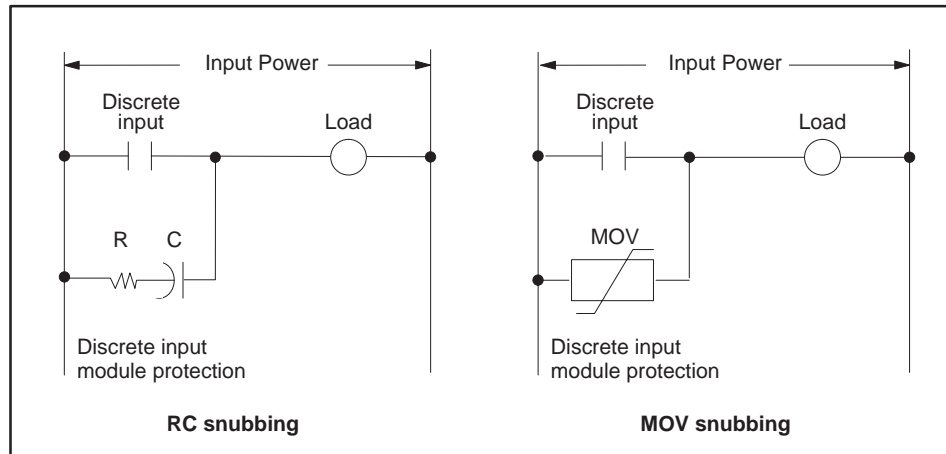

Figure 2-6 Contact Noise Snubbing

---

**NOTE:** Noise snubbing shown in Figure 2-6 is built into the PPX:505-5518 Relay Output module.

---



---

## Noise Isolation

The second approach to handling noise problems is to isolate the problem device and its wiring from the electronics and associated signal wiring. You may accomplish this by increasing the physical distance from some types of noisy devices. For extreme cases, electrostatic (metal) shielding may be required. This is true for noise sources outside as well as inside the mounting cabinet (NEMA-type recommended).

Two cases of field wiring warrant special attention; wiring which enters the harsh noise area to enable monitoring and control of those devices, and TTL or low-level (less than 24 V) wiring. In these cases, supplement the physical separation between control and noise-prone wiring with shielded, twisted-pair wiring (12 twists/ft) for the control signals.

Process transmitters should normally be grounded at the transmitter end. Use a single-point, shield ground as shown in Figure 2-7.

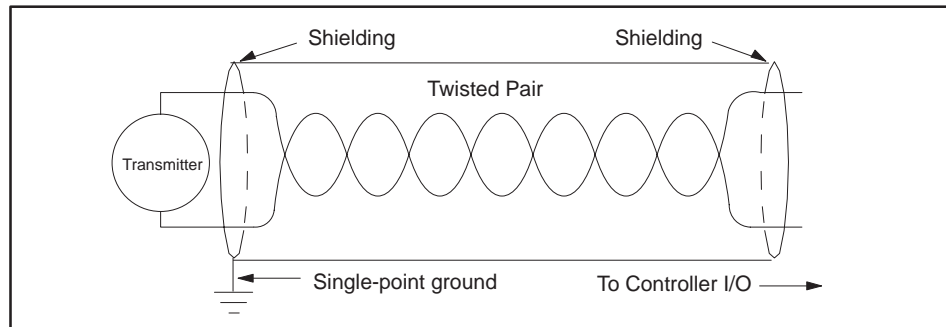

Figure 2-7 Grounding Shielded, Twisted Pair Cables

## 2.7 Wiring Considerations

---

### Guidelines

Consider the following guidelines before installing any system or power wiring.

- Always use the shortest possible single length cable.
- Avoid placing system and field wiring in the vicinity of high-energy and/or high frequency wiring.
- Keep field input wiring, output wiring, and all other types of wiring in the panel physically separated when possible.
- Consider separating DC field wiring from AC field wiring wherever possible.
- Avoid sharp bends to power and data cables. Use 7.6 cm (3 inches) radius on all bends.
- Ensure that a good low earth ground impedance of 0.1 ohm or less exists for all components in the system.
- Use metal wireways and conduit when possible.
- Keep wire strippings from falling into modules, controllers, or bases.
- For long return lines to the power supply, do not use the same wire for input and output modules. Using separate return wiring for these modules minimizes the voltage drop on the return lines of the input connections.

## 2.8 Power System Grounding

### Earth Ground

In some installations, a metal conduit that connects to the neutral phase at the circuit-breaker box supplies the earth ground of the power receptacle. Depending on site conditions, this metal conduit may conduct current from other sources that can interfere with the operation of the equipment.

To reduce this possibility, isolate earth ground and neutral from the conduit (except at the service entrance housing); see Figure 2-8. Ensure that system power is wired in accordance with National Electrical Manufacturers Association specifications. Also comply with the following:

- Ensure that the protective ground wire resistance is less than 0.1 ohm.
- Ensure that the resistance to earth ground is 0.1 ohm or less.

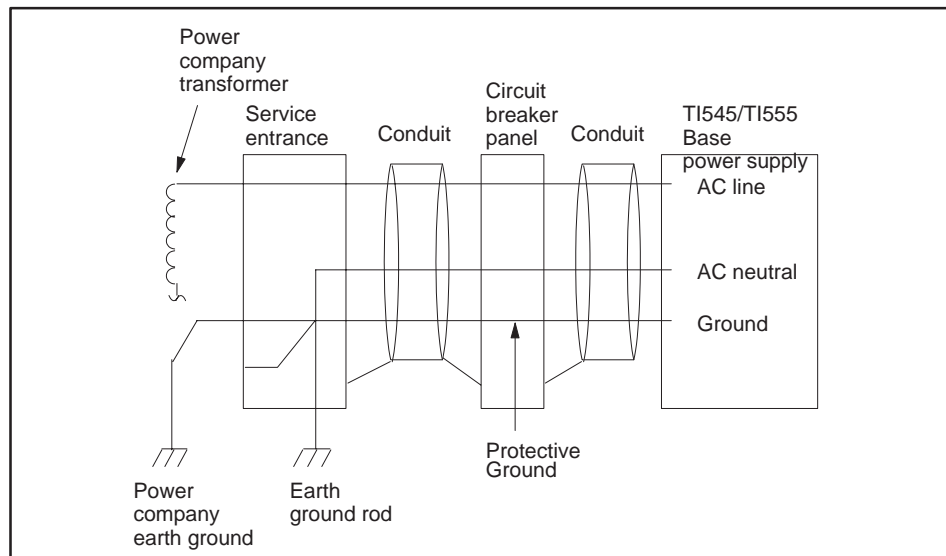

Figure 2-8 Isolating Ground and Neutral From Conduit

## Power System Grounding (continued)

### Grounding the Controller

When installing the controller, ensure that noise is minimized by following these guidelines. Use the ground connection (Figure 2-9) to attach one end of a ground wire; attach the other end to a nearby grounding rod that meets all electrical specifications required for an earth ground. Use the shortest possible length of #8-gauge copper wire, or equivalent braided cable to make the connection.

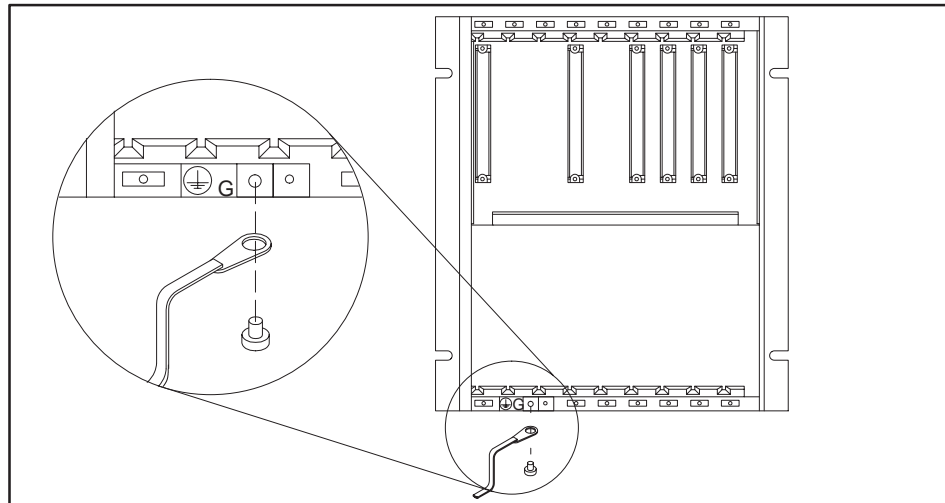

Figure 2-9 Grounding the TI545/TI555 Controller

### Grounding the Cabinet or Rack

If the controller is mounted in a cabinet or rack, use the same grounding procedure. Ensure that a good cabinet or rack ground connection is achieved by removing existing paint and attaching a #8-gauge copper wire (or equivalent) using a bolt, washers, and nut as necessary. You can attach the other end of the wire to the same ground rod used to ground the controller.

### Ground Connections

Use particular care when establishing the ground connections. The following techniques will help to establish good electrical connections and decrease noise interference:

- Terminate grounding braid and green wires at both ends with copper eye lugs to provide a good contact surface. Lugs should be crimped and soldered.
- Use #10 copper bolts (or equivalent) for those fasteners providing electrical connections to the single-point ground. This applies to device-mounting bolts and braid termination bolts for subpanel and user-supplied single points. Tapped holes for these fasteners are better than nut-bolt arrangements.
- Paints, coatings, and corrosion can prevent good electrical contact at ground points. Remove these impediments in the area of contact and use external toothed lock washers (star washers) to ensure good continuity and low impedance. This practice should be used for all terminations — lug to subpanel, device to lug, device to subpanel, subpanel to conduit, etc. Examples of ground connections are shown in Figure 2-10.

**⚠ CAUTION**

**A good grounding system is essential for proper operation of the system. It is one of the most important considerations in planning your installation.**

**Failure to provide a good grounding system could result in death or serious injury to personnel and/or damage to equipment.**

**Ensure that you have a good grounding system when you install your equipment.**

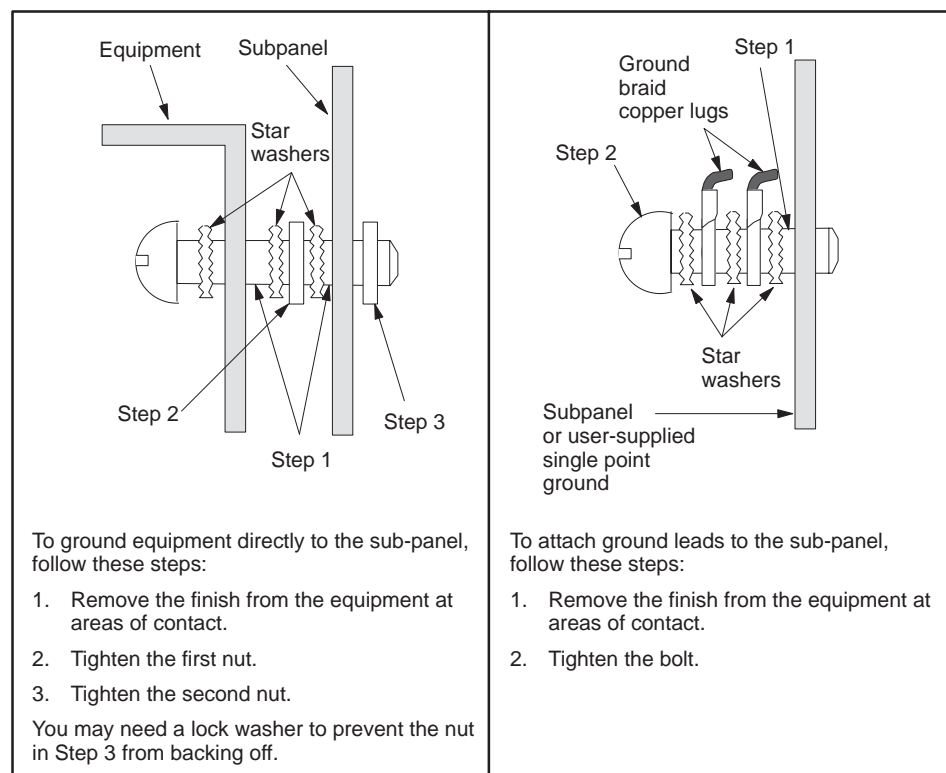

**Figure 2-10 Example of Ground Connection**

# Installing Series 505 System Hardware

---

<b>3.1</b>	<b>Overview of Installation Procedures</b> .....	<b>3-2</b>
<b>3.2</b>	<b>Series 505 Bases</b> .....	<b>3-3</b>
	Description .....	3-3
	Connecting Series 500 Bases .....	3-3
<b>3.3</b>	<b>Rack Mounting Series 505 Base</b> .....	<b>3-4</b>
	PPX:505-6516, 16-Slot Base .....	3-4
<b>3.4</b>	<b>Panel Mounting Series 505 Bases</b> .....	<b>3-5</b>
	Series 505 Bases PPX:505-6516, PPX:505-6508, PPX:505-6504 .....	3-5
<b>3.5</b>	<b>Installing Series 505 Power Supply</b> .....	<b>3-9</b>
	Power Budget for Series 505 Base .....	3-9
	Power Supply Placement in Bases .....	3-9
	Installing and Removing the Power Supply .....	3-9
<b>3.6</b>	<b>Installing the TI545/TI555 CPU</b> .....	<b>3-11</b>
	CPU/RBC Location in a Base .....	3-11
	Installing and Removing the CPU .....	3-12
	CPU Battery .....	3-13
	Setting CPU Dipswitches .....	3-13
	Using Port 1 .....	3-14
	Using Port 2 .....	3-14
	Setting Baud Rates .....	3-15
	Enabling Battery Backup .....	3-15
<b>3.7</b>	<b>Installing Series 505 Remote Base Controller</b> .....	<b>3-16</b>
	RBC Placement in Bases .....	3-16
	Dipswitches .....	3-16
	Setting RS-232 Port Baud Rates (SW 2) .....	3-16
	Series 505 RBC SW 3 (Factory) Dipswitch Settings .....	3-17
	Output State Selection .....	3-17
	Installing and Removing Series 505 RBC .....	3-19
	Assigning RBC Base Numbers .....	3-19
	Series 505 RBC LED Display .....	3-20
<b>3.8</b>	<b>Installing Series 505 I/O Modules</b> .....	<b>3-21</b>
	Mixing I/O Modules .....	3-21
	Installing and Removing I/O Modules .....	3-21

## 3.1 Overview of Installation Procedures

---

The following chart identifies the tasks for installing Series 505 system hardware.

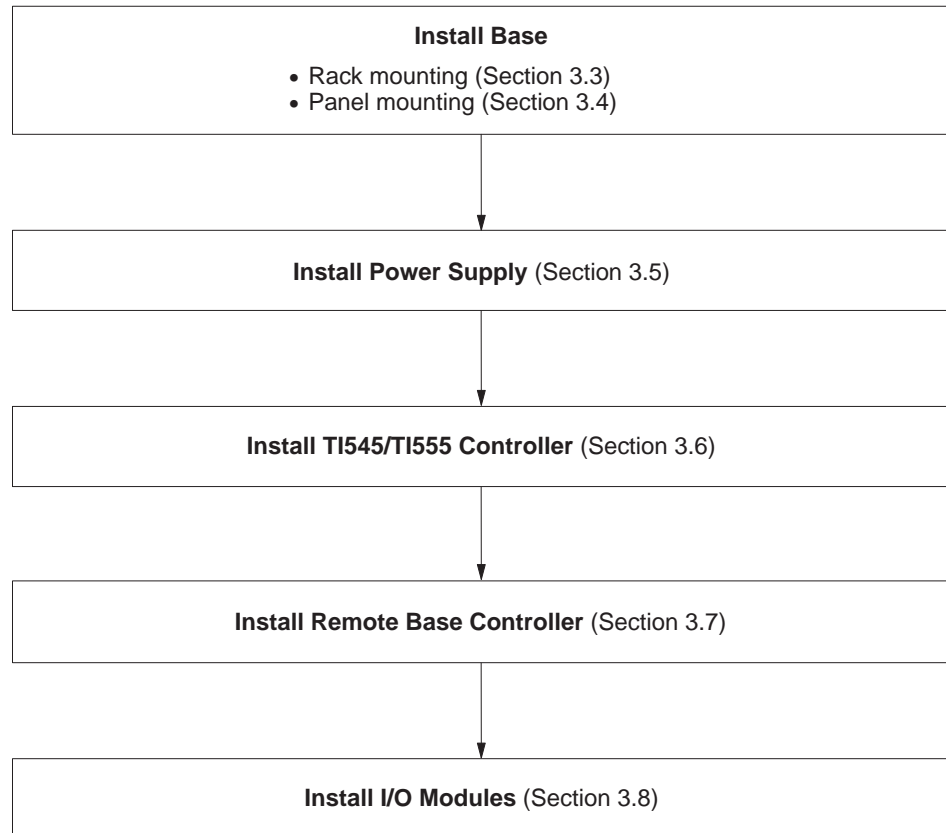

## 3.2 Series 505 Bases

---

**Description** The controller is housed in a Series 505 base assembly. A base assembly has slots for the programmable controller or remote base controller (RBC), power supply, and the I/O modules. Four base assembly models are currently available (see Table 3-1).

Table 3-1 Base Assembly Models

<b>Model</b>	<b>Number of Slots</b>	<b>Mounting</b>
PPX:505-6504	4	NEMA panel
PPX:505-6508	8	NEMA panel
PPX:505-6511	11	NEMA panel or rack
PPX:505-6516	16	NEMA panel or rack

**Connecting Series 500 Bases** Series 500 bases can be connected to a TI545/TI555 PLC system as a remote I/O base assembly. The TI545/TI555 controller is capable of addressing the Series 500 base assembly through the RBC (PPX:500-5114-A). See Appendix D for information about upgrading Series 500 bases.

Using the PPX:505-6860 RS-485/RF Converter the TI545/TI555 controller can connect to the TI545/TI555 Bases in an RF I/O Channel using the PPX:500-2114A or the TI505-6850-A RBCs. Refer to the *SIMATIC TI505 Redundant I/O Systems User Manual*, PPX:505-8125-x for additional information.



### 3.3 Rack Mounting Series 505 Base

---

PPX:505-6516,  
16-Slot Base

Use the following steps, and Figure 3-1, for mounting the base in a standard 19-inch rack.

1. Align two bracket holes with two screw holes located on the sides of base.
2. Secure each bracket to base with two screws installed through the bracket holes.
3. Position the base in the 19-inch rack. Depth of base is 7.99 inches (20.3 cm).

---

**NOTE:** There should be at least 6 inches (15.24 cm.) of clearance at the top and bottom of base for adequate airflow.

---

4. Align two bracket slots with two screw holes located on each side of the 19-inch rack. See Figure 3-1.
5. Secure each bracket to the 19-inch rack with two screws installed through the the bracket slots. See Figure 3-1.

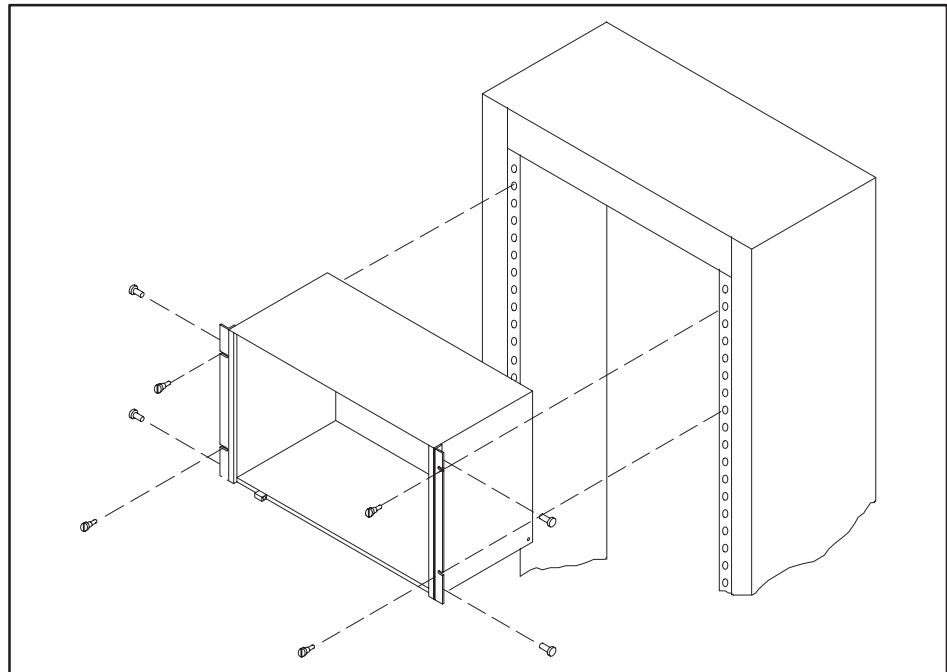

Figure 3-1 Mounting Base to Standard 19-inch Rack

### 3.4 Panel Mounting Series 505 Bases

Series 505 Bases  
PPX:505-6516,  
PPX:505-6508,  
PPX:505-6504

Use the following steps for panel mounting in an NEMA enclosure.

1. Open NEMA enclosure door.
2. Drill four holes in sub-panel of NEMA enclosure with a #21 drill bit. Refer to Figure 3-2 through Figure 3-4 for screw-hole dimensions for each base.

**NOTE:** There should be at least 6 inches (15.24 cm.) of clearance at the top and bottom of base for adequate airflow. The base depth is 7.99 inches (20.3 cm.).

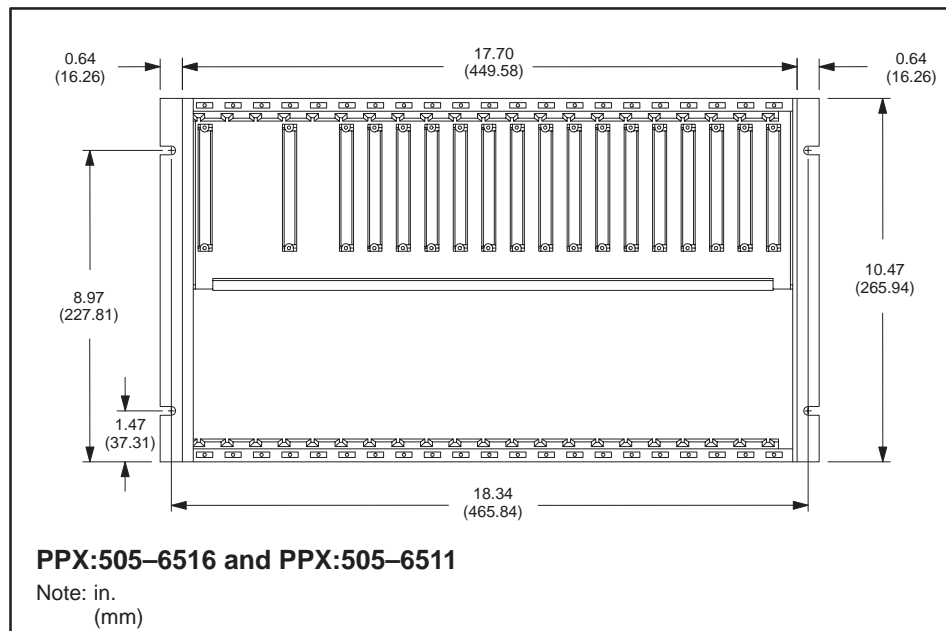

Figure 3-2 Screw-hole Dimensions for PPX:505-6516/6511 Bases

## Panel Mounting Series 505 Bases (continued)

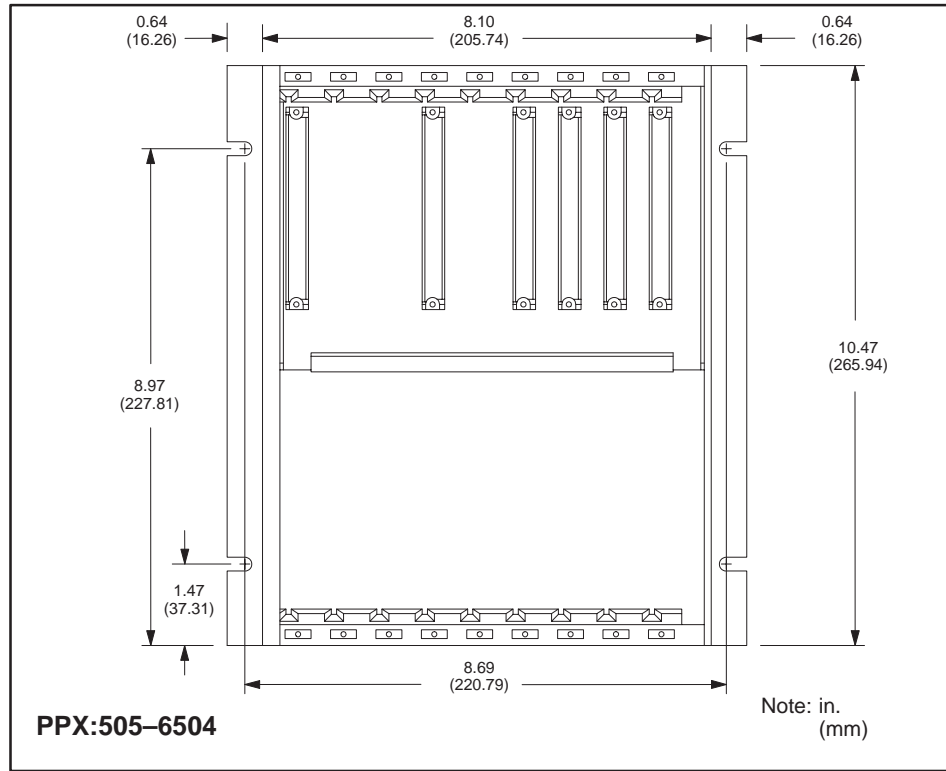

Figure 3-3 Screw-hole Dimensions for PPX:505-6504 Bases

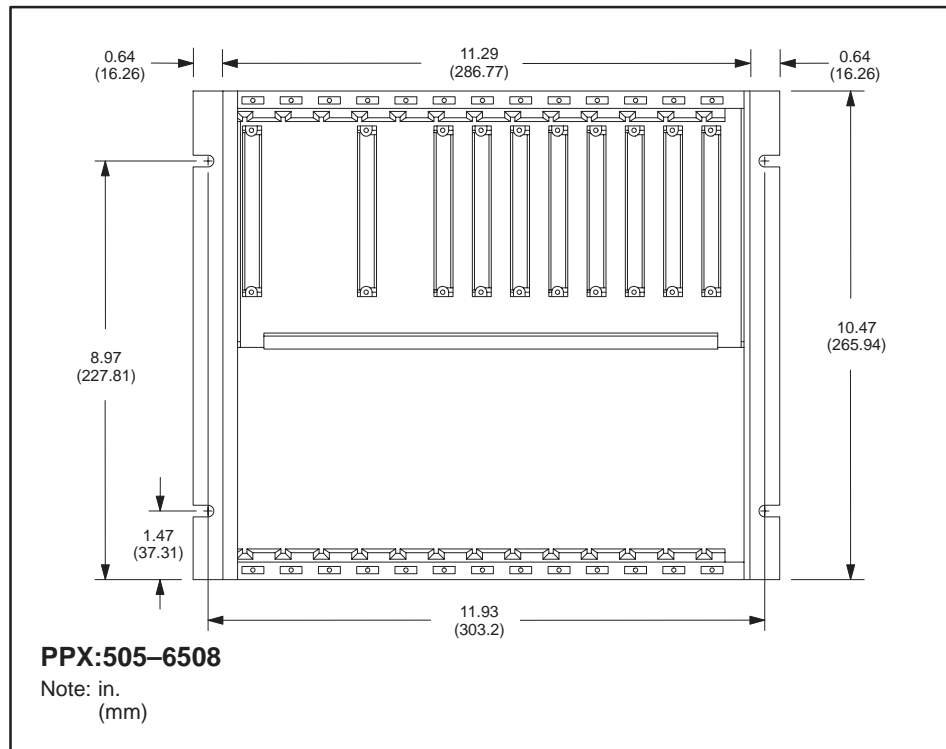

Figure 3-4 Screw-hole Dimensions for PPX:505-6508 Bases

## Panel Mounting Series 505 Bases (continued)

---

3. Tap the drilled holes with a #10-32 tap.
4. Align two bracket holes with two screw holes located on each side of base. See Figure 3-5.
5. Secure each bracket to base with two screws installed through the bracket holes. See Figure 3-5.

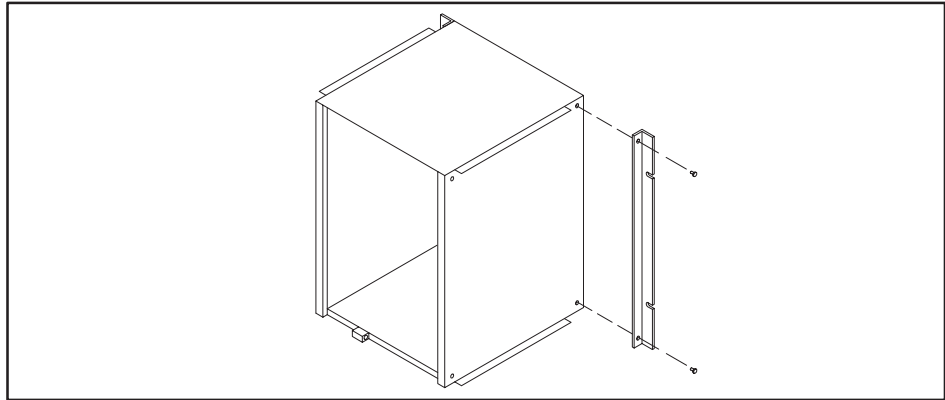

Figure 3-5 Mounting Brackets to Base

6. Position the base inside the NEMA enclosure.

---

**NOTE:** Be sure that the bracket holes and the tapped holes in the sub-panel are aligned.

---

7. Install #10 screws through each bracket hole to attach the base to the sub-panel. See Figure 3-6.

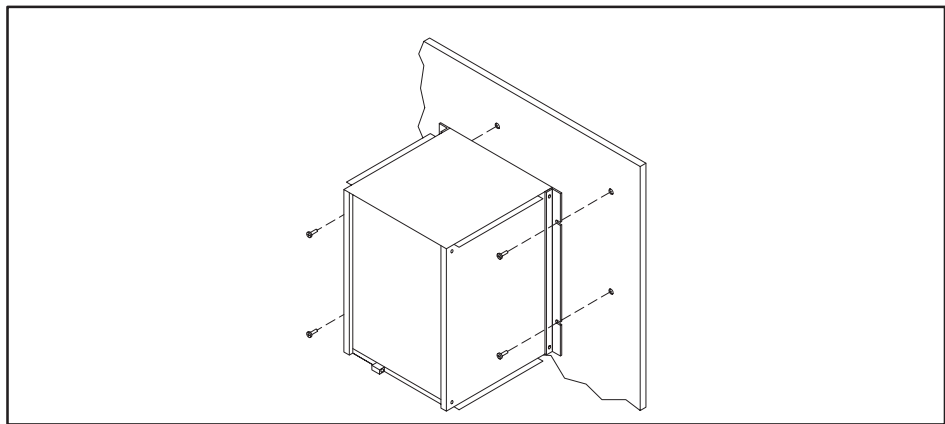

Figure 3-6 Mounting Base in NEMA Enclosure

### 3.5 Installing Series 505 Power Supply

---

**Power Budget for Series 505 Base**

The total power consumption of all I/O modules (including the programmable controller and RBC) drawing power from a Series 505 power supply must not exceed 55.0 W from the +5 VDC output and 3.75 W from the -5 VDC output. Refer to Appendix B for power consumption listings for the controller and all currently available Series 505 I/O modules and RBCs.

**Power Supply Placement in Bases**

See Figure 3-7 for power supply placement in Series 505 bases. The power supply must always be installed in the left-most slot.

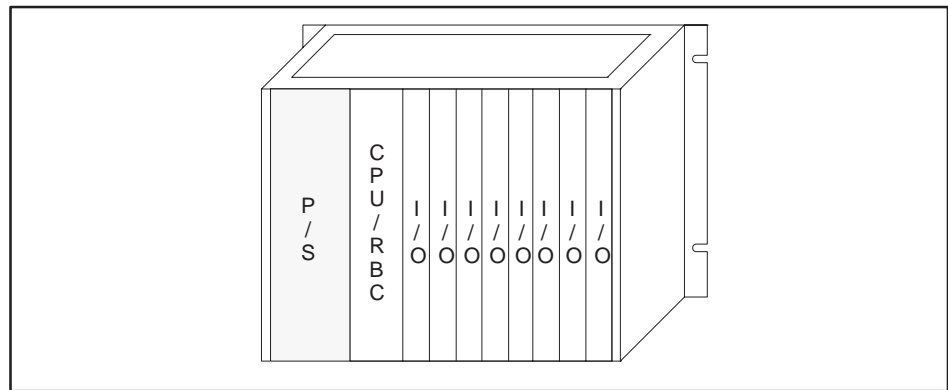

Figure 3-7 Series 505 Module Placement in Base

**Installing and Removing the Power Supply**

Use the steps that follow to install or remove the Series 505 base power supply.

1. Disconnect power to the base.

---

**⚠ WARNING**

**Disable all power to the base before installing or removing any module.**

**Failure to do so could cause death or serious injury and/or damage to equipment.**

**Ensure that all power is disabled before you install or remove any module.**

---

### ⚠ CAUTION

**Attempting to operate the PPX:505-6660 power supply at 220 VAC with 110 VAC selected, or 110 VAC with 220 VAC selected, results in damage to power supply.**

**Attempting to operate the PPX:505-6663 power supply outside the designed voltage range of 20 to 30 VDC may cause damage to the power supply.**

**Double check your power supply voltage before you attempt operation.**

---

2. Connect the voltage selector connector to TAB1 for 110 VAC input power or TAB2 for 220 VAC input power when installing the PPX:505-6660 power supply. See Figure 3-8.

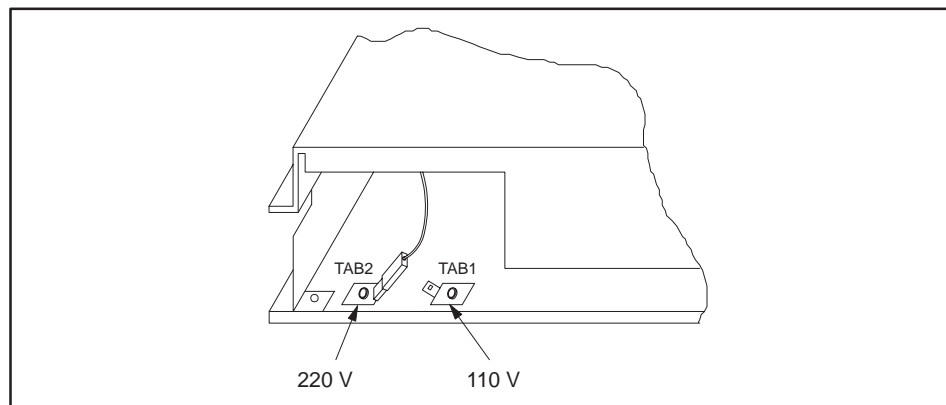

Figure 3-8 Selecting Input Voltage—PPX:505-6660 Only

3. Position the power supply so that the bezel is facing you.
4. Grasp the top and bottom of the power supply.
5. Carefully push the power supply into the slot until it mates with the backplane connectors.
6. Tighten top and bottom bezel screw. (Refer also to Figure 3-10.)

To remove the Series 505 Power Supply, simply reverse the procedures used during installation.

### 3.6 Installing the TI545/TI555 CPU

---

CPU/RBC Location  
in a Base

The CPU/RBC must always be installed in the second slot from the left (beside the power supply module), as shown in Figure 3-9.

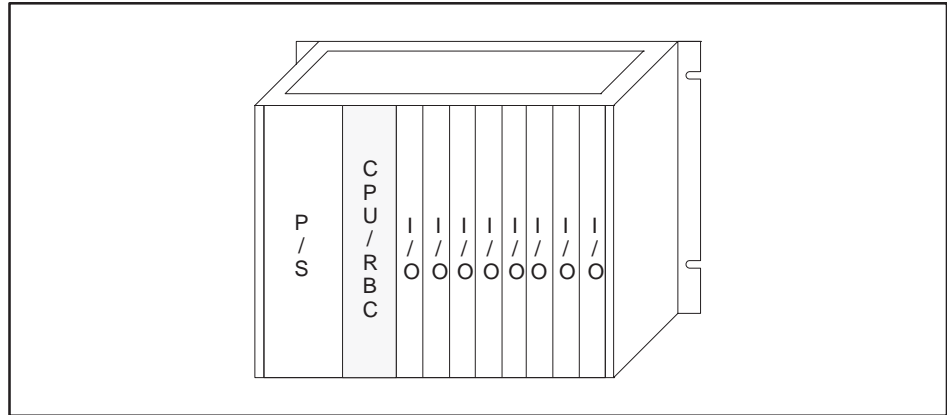

Figure 3-9 Location of CPU/RBC in a Series 505 Base

---

**⚠ CAUTION**

**Electronic equipment can be damaged by electrostatic discharge.**

**Ensure that personnel make contact with a grounded conductive pad and/or wear a grounded wrist strap when handling the controller cards or modules.**

---



## Installing the TI545/TI555 CPU (continued)

---

Installing and  
Removing the CPU

Refer to Figure 3-10 and follow the steps below to install the CPU.

1. Disconnect power to the base.

---

**! WARNING**

**Disable all power before installing or removing the CPU.**

**Failure to do so could cause death or serious injury and/or damage to equipment.**

**Ensure that all power is disabled before installing or removing the CPU.**

---

2. Position the CPU so that the bezel is facing you.
3. Grasp the top and bottom of the CPU module.
4. Carefully push the module into the slot until it mates with the back plane connectors.
5. Tighten top and bottom bezel screws.

To remove the CPU, disconnect the RS-485 cable from the I/O port, if it is connected, and reverse the installation procedure.

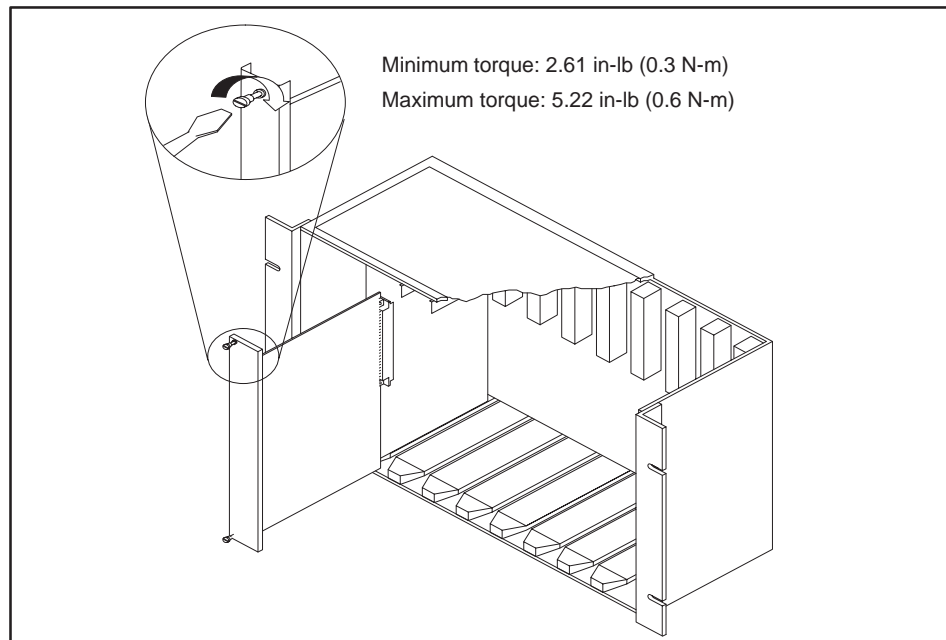

Figure 3-10 Installing CPU Module in a Series 505 Base

## CPU Battery

A permanent, rechargeable battery protects user memory and programs during a power cycle. Battery backup typically lasts six months at temperatures ranging from 0° to 60°C provided the battery was fully charged.

If the battery LED does not light, the battery may be discharged. A blinking LED indicates a marginal charge. The LED lights steadily when the battery is sufficiently charged with the switch enabled and power applied. The battery will be only be fully charged following 36 hours of being powered after the LED first lights steadily.

Because the CPU contains a 3 V lithium battery that is soldered in the CPU module, the CPU must be sent to the factory to replace the battery. Refer also to Section 7.2 for more information on the battery LED.

## ⚠ CAUTION

**Battery Damage: Do not leave the unit powered down with the battery switch on for longer than six months.**

**Doing so could damage the battery to the point it cannot be recharged.**

**Return a unit in this condition to the factory for battery replacement.**

## Setting CPU Dipswitches

Dipswitches are used to set CPU operating parameters. The dipswitches are located near the front of the CPU behind the bezel door; see Figure 3-11. To gain access, lower the access door. With the CPU in its (normal) vertical position, dipswitches pushed to the left are On; dipswitches pushed to the right are Off.

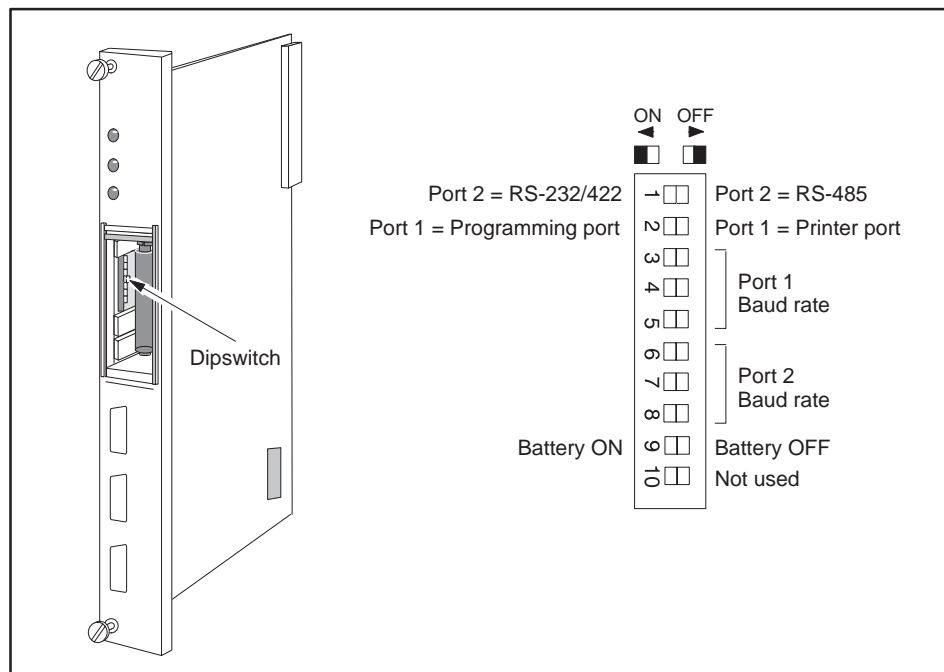

Figure 3-11 CPU Dipswitch Location

## Installing the TI545/TI555 CPU (continued)

### Using Port 1

Switch 2 selects Port 1 as, either a programming port, or a printer port; see Figure 3-12 for port locations. This port uses a RS-232/RS-423 signaling protocol and uses a RS-232 pinout arrangement with a RS-423 (+5 V) signal level extending up to 50 feet. A modem may be used to increase the cable distance.

- Setting Switch 2 to the left selects Port 1 as a programming port.
- Setting Switch 2 to the right selects Port 1 as a printer port.

### Using Port 2

Selection between RS-232/RS423 or RS-422/RS-485 is accomplished by cabling. If RS-422/RS-485 cabling is used, then dipswitch 1 selects between RS-422 and RS-485 (see Figure 3-11). The cable installation for RS-485 or RS-422 can include a 120-ohm termination resistor across the signal conductors at each end of the cable. The resistor provides a higher noise immunity and better long-distance communication (see Figure 3-12).

- RS-232/RS-423 connection for Operator Interface up to 50 feet.
- RS-422/RS-485 connection to 3300 feet (1 km).

Switch 1 is used as follows:

- When RS-232 or RS-422 cabling is used, set Switch 1 to the left.
- When RS-485 cabling is used, set Switch 1 to to the right. RS-485 uses a single twisted pair to transmit and receive data between the programming device and the CPU. Multiple CPUs or multiple programming devices (on this RS-485 link) are currently not supported and should not be used.

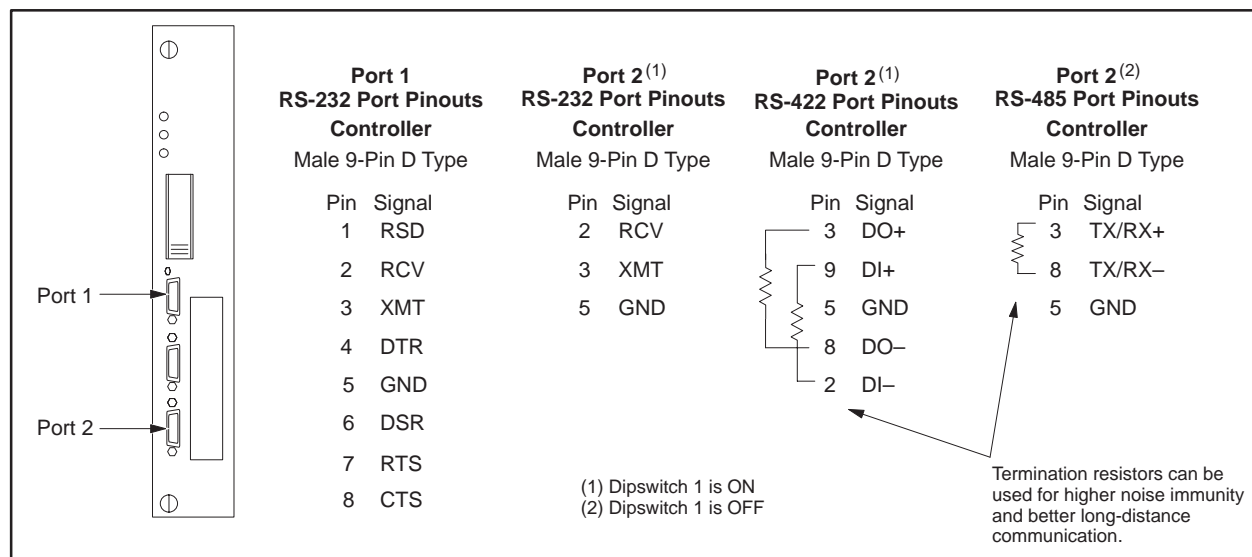

Figure 3-12 TI545/TI555 CPU Port Locations

---

## Setting Baud Rates

Switches 3 through 8 are used to set baud rates for Ports 1 and 2. Switches 3, 4, and 5 set Port 1 baud rates (Table 3-2). Switches 6, 7, and 8 set Port 2 baud rates (Table 3-3).

Table 3-2 Port 1 Baud Rate Settings

Baud Rate	Dipswitches		
	3	4	5
19200	On	On	On
9600	Off	On	On
2400	Off	Off	On
1200	Off	On	Off
300	Off	Off	Off

Table 3-3 Port 2 Baud Rate Settings

Baud Rate	Dipswitches		
	6	7	8
19200	On	On	On
9600	Off	On	On
2400	Off	Off	On
1200	Off	On	Off
300	Off	Off	Off

## Enabling Battery Backup

Switch 9 is used to set the backup battery On or Off; see Figure 3-11. Moving the switch to the left sets the backup battery On; setting the switch to the right sets the backup battery Off.

---

**NOTE:** The battery in the CPU is rechargeable. The battery LED indicates the state of the battery backup circuit (when switch 9 is ON) as follows:

OFF	Low Battery	backup will not work
FLASHING	Marginal or charging	backup may work
ON	Good battery	backup should work

---

### 3.7 Installing Series 505 Remote Base Controller

#### RBC Placement in Bases

The RBC must always be installed in the second slot from the left (adjacent to the power supply module) in a remote base.

#### Dipswitches

There are two dipswitches, SW 2 and SW 3, located on the components side of the RBC. SW 2 (Figure 3-13) is used to set baud rates. SW 3 is a factory-use-only switch.

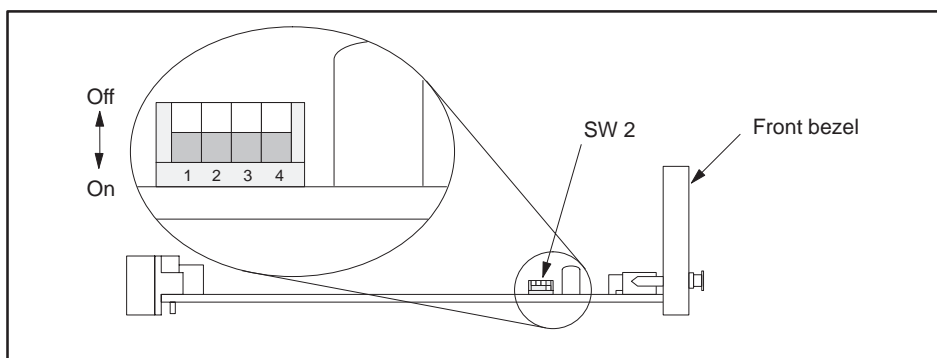

Figure 3-13 RBC Dipswitch Location

#### Setting RS-232 Port Baud Rates (SW 2)

Dipswitch SW 2 is used to set baud rates for the RBC RS-232 port. The RS-232 port is used to program the controller or to troubleshoot from a remote I/O base.

See Figure 3-13 for positions of SW 2 on the board; refer to Table 3-4 for individual dipswitch settings.

Table 3-4 RBC SW 2 (RS-232 Port) Baud Rate Settings

Baud Rate	Dipswitch			
	1	2	3	4
19200	On (1)	On (1)	Off (0)	On (1)
9600	On (1)	On (1)	On (1)	On (1)
2400	Off (0)	On (1)	On (1)	On (1)
1200	On (1)	Off (0)	On (1)	On (1)
300	Off (0)	Off (0)	On (1)	On (1)

---

Series 505 RBC  
SW 3 (Factory)  
Dipswitch Settings

The factory dipswitch, labeled SW 3 on the board is for factory use only. Do not change the settings on this dipswitch. If the dipswitch setting is accidentally changed, or you are installing a new RBC, refer to Table 3-5 for the proper dipswitch settings.

Table 3-5 Series 505 RBC SW 3 (Factory) Dipswitch Setting

Dipswitch			
1	2	3	4
On	Off	Off	Off

Output State  
Selection

You can select the state you want the outputs, controlled by the RBC, to be set to whenever a communication error occurs. Previous models of the RBC automatically set all outputs to off (0) when communication is lost. The A version of RBCs allow you to either freeze the outputs in the state they were in when communication was lost, or have the outputs set to off (0).

---

 **WARNING**

**Energized parts could fail in an unsafe condition.**

**If the RBC fails or the system loses power, the outputs will go off (0) regardless of the jumper selection.**

**This could cause damage to equipment or death or injury to personnel.**

---

## Installing Series 505 Remote Base Controller (continued)

The RBC has a jumper to select the output state during a communication loss (Figure 3-14). If the output modules in the remote base have a selection switch, the freeze selection will override the output module's selection.

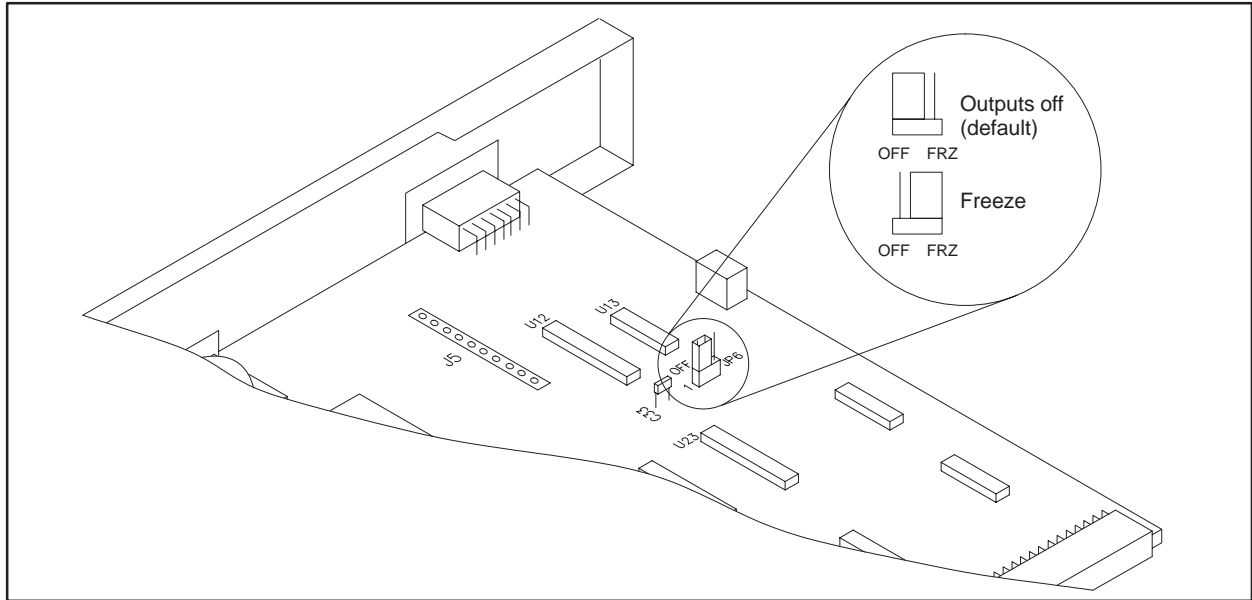

Figure 3-14 Series 505 RBC Jumper Locations

---

Installing and  
Removing  
Series 505 RBC

 CAUTION

Use the following steps to install and remove a Series 505 RBC.

---

**The RBC can be damaged by electrostatic discharge.**

**Ensure that personnel make contact with a grounded conductive pad and/or wear a grounded wrist strap when handling the RBC.**

---

1. Disconnect power to the base.

 WARNING

---

**Disable all power to the base before installing or removing the RBC.**

**Failure to do so could cause death or serious injury and/or damage to equipment.**

**To prevent disruption of the I/O channel, disconnect the RS-485 cable before removing or installing an RBC.**

---

2. Position the RBC so that the bezel is facing you.
3. Grasp the top and bottom of the RBC.
4. Carefully push the RBC into the slot until it mates with the back plane connectors.
5. Tighten top and bottom bezel screws.

To remove the RBC module, complete these steps.

1. If attached, remove cables from the front of the RBC.
2. To complete the removal of the RBC module, simply reverse procedures used during installation.

Assigning RBC  
Base Numbers

A base thumbwheel is used to assign a base number to the RBC for system identification. If you are using more than one RBC, each RBC must be uniquely numbered. Base numbers are the same as the thumbwheel number except for base 0, which is reserved for local base assignment and cannot be used by Series 505 RBCs.



## Installing Series 505 Remote Base Controller (continued)

### ⚠ WARNING

**Control devices can fail in an unsafe condition that could result in death or serious injury and/or damage to equipment.**

**Do not change the base thumbwheel numbers when the system is operating. This may cause the base to be logged off the system.**

**When the base is logged off the system, all discrete outputs will be turned off, analog outputs will be frozen, and word and discrete inputs will go to 0.**

### Series 505 RBC LED Display

The display at the top of the module (see Figure 3-15) indicates the status of the Series 505 RBC. Status is displayed in integer format; see Table 3-6 for definitions of the displays.

Table 3-6 Series 505 RBC LED Messages

Display	Definitions
0	RBC Good
1	Self Diagnostics Failure
2	Module Mismatch
3	I/O Communication Time Out
4	RAM Parity Error
5	Standby, No Configuration
6	Address Mismatch
7	Communication Good, No Configuration
8	Watchdog Time Out
C	Standby, Configuration

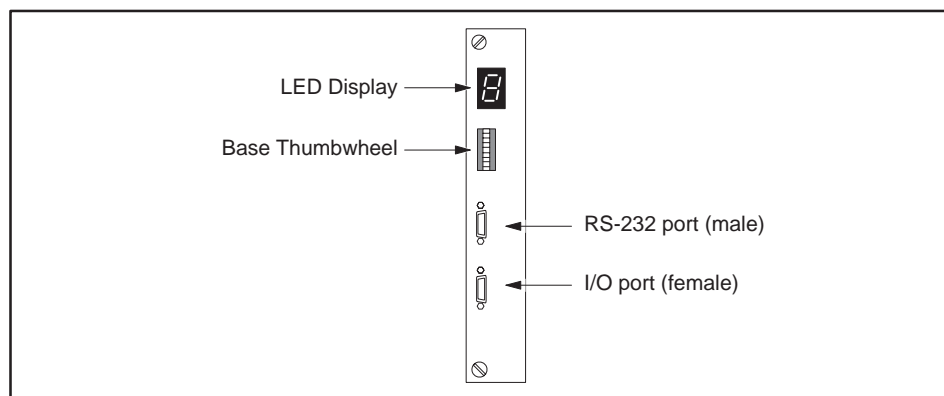

Figure 3-15 Series 505 Remote Base Controller

## 3.8 Installing Series 505 I/O Modules

### Mixing I/O Modules

A mix of I/O modules can be used with one base; you can combine input, output, word input, word output, and intelligent modules in a single base.

### Installing and Removing I/O Modules

Use the following steps for installing and removing Series 505 I/O modules in the base. (Refer to Figure 3-16.)

1. Disconnect power to the base.

### WARNING

**Disable all power to the base before installing or removing I/O modules.**

**Failure to do so could cause death or serious injury and/or damage to equipment.**

**Ensure that all power is disabled before you install or remove I/O modules.**

2. Use specification sheets provided with the modules to install option and wiring selections for your application.
3. Position the I/O module so the bezel is facing you.
4. Grasp the top and bottom of the I/O module.
5. Carefully push the I/O module into the slot until it mates with the back plane connectors.
6. Tighten top and bottom bezel screws.

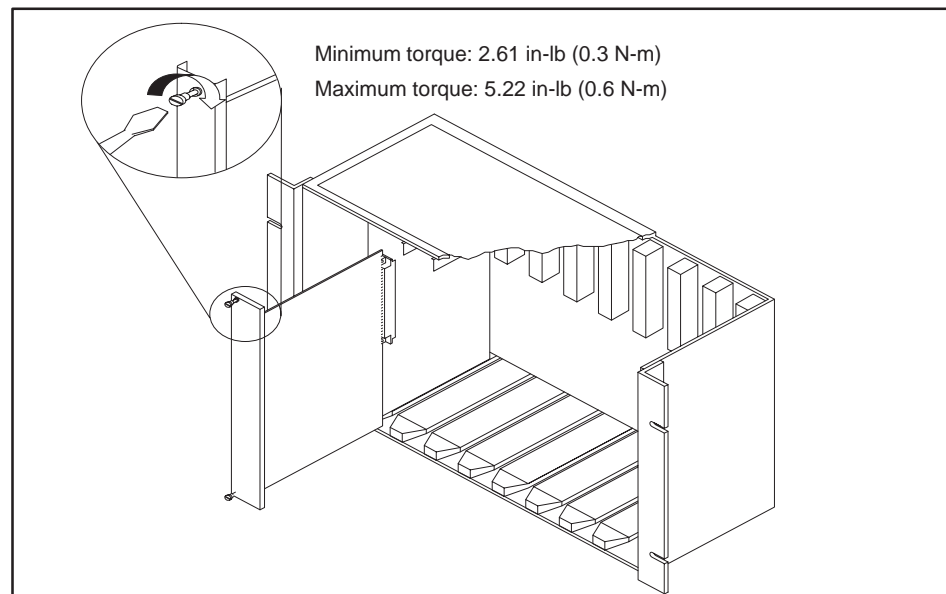

Figure 3-16 Installing and Removing Modules in a Series 505 Base

To remove the I/O module, reverse procedures used during installation.

# Cabling and Wiring the System

---

<b>4.1</b>	<b>Connecting Input Power</b> .....	<b>4-2</b>
	Guidelines .....	4-2
	Wiring Power Supply .....	4-2
<b>4.2</b>	<b>Cable Routing</b> .....	<b>4-4</b>
	Guidelines .....	4-4
	Cable Routing Methods .....	4-4
	Under-Floor Routing .....	4-5
	In-Ceiling Routing .....	4-5
	Surface Duct Routing .....	4-5
	Mounting the Tap or Terminal Block .....	4-5
<b>4.3</b>	<b>Installing Remote I/O Cables</b> .....	<b>4-6</b>
	Cabling Options .....	4-6
	Trunk and Drop Lines .....	4-6
	User-Supplied Equipment .....	4-7
	Mounting the Terminal Block .....	4-7
	Programmable Controller and RBC Drop Lines .....	4-7
	Preparing Cables (for Drop Lines) .....	4-8
	Connecting a CPU Drop Line .....	4-9
	Connecting the RBC Drop Line .....	4-11
	Connecting Terminal Block Trunk Lines .....	4-12
	Alternate Cables .....	4-13
	Configuration Requirements .....	4-14
	Preparing Trunk Line Cables .....	4-16
	Connecting Trunk Line to Terminal Blocks .....	4-17
<b>4.4</b>	<b>Connecting Modems</b> .....	<b>4-18</b>
	Overview .....	4-18
	Dedicated Line Operation .....	4-19
	Dial-up Phone Line Operation .....	4-19
<b>4.5</b>	<b>Connecting a Printer</b> .....	<b>4-20</b>
	Overview .....	4-20

## 4.1 Connecting Input Power

---

- Guidelines** To connect the Series 505 power supply, and the Series 500 remote I/O base to the external power source, follow these guidelines.
- Use 14 AWG solid or stranded wire. If you use stranded wire, the wire should be twisted and trimmed.
  - Strip insulation back 0.40 inches (10mm).
  - Insert the wires fully into the terminal block so that the insulation butts against the block.

**Wiring Power Supply** Use the following steps for connecting input power to the power supply. See Figure 4-1.

1. Disconnect power to the base.

---

**⚠ WARNING**

**Disable all power before attempting the wiring procedures. Failure to do so could cause death or serious injury and/or damage to equipment.**

**Ensure that all power is disabled before attempting the wiring procedures.**

---

2. Loosen three power connector screws.
3. Connect wires as appropriate for your power supply module.

Model PPX:505–6660A: insert ground, neutral, and AC line wires into socket on the power supply. This power supply requires 110 or 220 VAC.

---

**⚠ CAUTION**

**Ensure that PPX:505–6660A power supply is set to operate on 110 VAC or 220 VAC to match the input power. See Chapter 3 for selecting voltage for this power supply.**

**Attempting to operate the power supply at 220 VAC with 110 VAC selected, or 110 VAC with 220 VAC selected, will result in damage to the power supply.**

**Double check your power supply voltage before you attempt the operation.**

---

Model PPX:505–6663: insert chassis ground, DC–, and DC+ line wires into socket on the power supply. This power supply requires 24 VDC.

4. Tighten screws.
5. Refer to Chapter 2 for grounding guidelines.

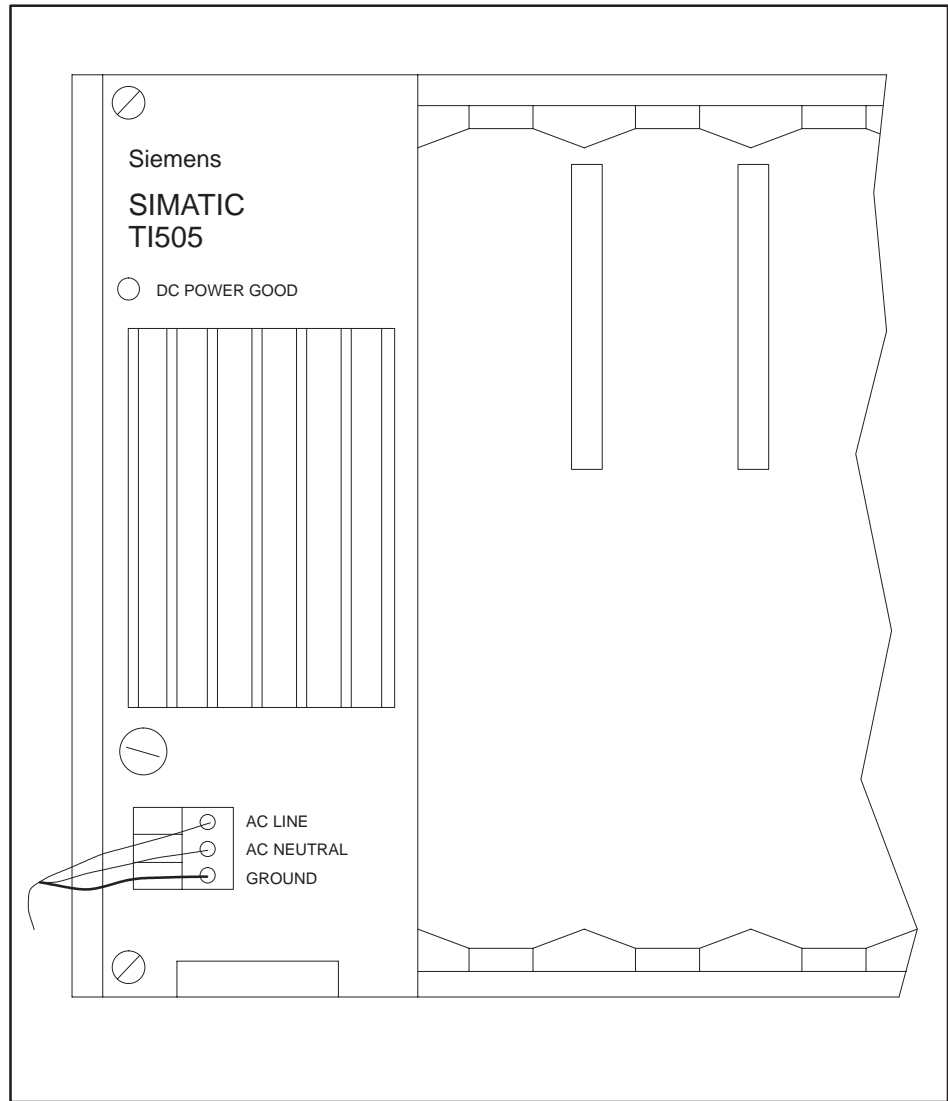

Figure 4-1 Supplying Power with the PPX:505-6660A

## 4.2 Cable Routing

---

### Guidelines

Follow these suggestions when planning your cable routing.

- Allow for system growth. Provide for attachment of future I/O bases by routing cable through all possible areas of plant expansion.
- The TI545/TI555 can have a trunk line (attached to its I/O) that extends up to 3300 feet (1000 m) using RS-485 (twisted pair) cables.
- Take steps to bypass or eliminate noise sources to reduce system data error rates. The following are common sources of electrical noise.
  - Power distribution mains
  - Arcing motors
  - Fluorescent lighting
  - Undesired signal transfer between adjacent circuits
  - Poor terminations of cable connector
- Do not allow the trunk cable to come into contact with any other electrical conductor.
- If cabling is installed inside a conduit, the conduit should be grounded according to applicable electrical codes.
- Maintain a minimum of 3 feet (0.91 m) between trunk lines and the following noise sources.
  - Power lines
  - Electric motors and motor starters
  - Generators
  - Electric welders

### Cable Routing Methods

The type of routing is usually determined by the type of building in which the cables are being installed. Any combination of the following may be used to route the cables: under-floor, in-ceiling, or surface duct.

---

**NOTE:** Electrical and fire safety must be considered in planning the installation. Modern codes seek to limit the hazard of cable installations as a means of propagating fire and smoke. In order to ensure a proper level of safety compliance, observe local installation code practices and guidelines.

---

---

**Under-Floor Routing**

In under-floor routing, the cable can be enclosed in ducts or, with raised flooring, in the open air.

- Duct systems are better protected against unauthorized taps or terminal blocks, but expansion is more difficult and expensive than with open air systems.
- Open air systems provide more freedom of access, and allow maximum system expansion and flexibility.

**In-Ceiling Routing**

For in-ceiling routing, cables are usually supported in troughs or with hooks and clamps every 10 or 15 feet (3.05 or 4.57 m).

Some advantages of in-ceiling routing follow:

- Flexibility.
- Low cost installation.
- Accessibility of cabling.

Some disadvantages of in-ceiling routing are:

- Collection of dust and other debris in ceilings.
- Hazardous working conditions in ceilings.
- Impracticality for buildings without drop ceilings.

**Surface Duct Routing**

Surface ducting is usually installed along baseboards or attached to walls at desktop height. While surface ducting ordinarily protects cables from both physical and electro-magnetic (E/M) effects, it usually requires I/O bases to be positioned near a wall.

---

**NOTE:** Consult your cable vendor for proper cable-pulling techniques so that no kinks occur in the cable during installation.

---

**Mounting the Tap or Terminal Block**

Installation procedures for mounting the tap or terminal block depend upon the cable installation technique used. Refer to mounting instructions provided by the tap or terminal block vendor.

## 4.3 Installing Remote I/O Cables

### Cabling Options

Effective with Firmware Release 3.0 the TI545/TI555 provides two cabling options for the remote I/O system:

- Non-redundant I/O cabling using twisted pair (RS-485) media.
- Redundant I/O cabling using coaxial (RF) media.

This manual describes the twisted pair media. If you are installing a Redundant I/O system follow the instructions in the *SIMATIC TI505 Redundant I/O Systems User Manual*, PPX:505-8125-2.

### Trunk and Drop Lines

Use RS-485 cabling to install your trunk and drop lines after you have installed other system hardware items.

Figure 4-2 shows a typical application. The following sections provide information on cabling the TI545/TI555 controller and RBCs designed for RS-485 cables. These models are as follows:

- Programmable Controller — PPX:545-1102, PPX:555-1101, or PPX:555-1102.
- RBC — PPX:505-6851-A for Series 505 bases.
- RBC — PPX:500-5114-A for Series 500 bases (see Appendix D).

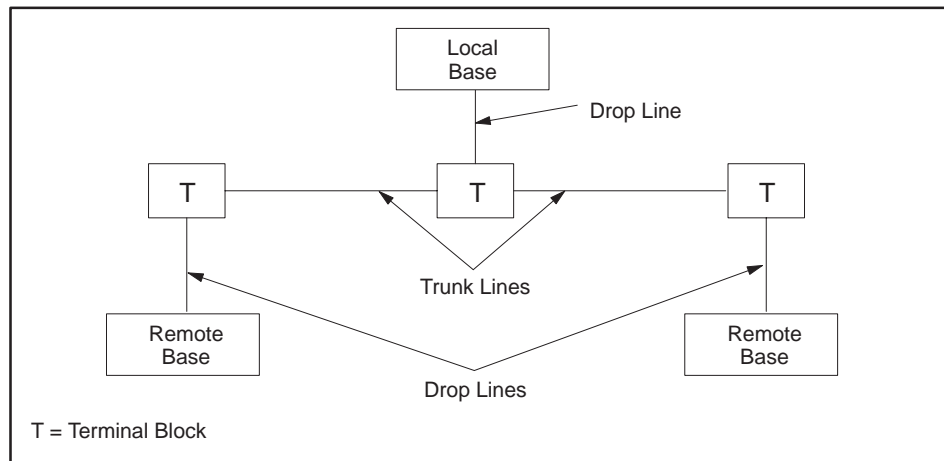

Figure 4-2 Trunk and Drop Line Example



---

**User-Supplied  
Equipment**

User-supplied components are listed below:

- RS-485 cables.
- Taps (terminal blocks).
- 9-Pin D-connectors (male) and shell.
- Terminal lugs.

**Mounting the  
Terminal Block**

Installation procedures for mounting the terminal block depend upon the cable installation technique used. Refer to mounting instructions provided by the terminal block vendor for additional information.

**Programmable  
Controller and  
RBC Drop Lines**

The cable that connects the programmable controller and RBC to a terminal block is called a drop line (Figure 4-2). Belden® cable type 9271 and 9182 should be used for all drop lines.

---

**NOTE:** If the trunk line is Belden cable type 9182, the drop line must be Belden cable type 9182.

If the trunk line is Belden cable type 9860 or 9271, the drop line can be Belden cable type 9271 or 9182.

---

## Installing Remote I/O Cables (continued)

---

### Preparing Cables (for Drop Lines)

Use the following procedures to prepare drop line cables to connect the programmable controller and RBC to terminal blocks:

1. Strip back 1.50 inches (3.8 cm) of the sleeving on one end of the cable. There are three wires when the sleeving is stripped back; two wires have color coded insulation jackets and one is bare.
2. Remove 0.13 in. (0.33 cm) of each color coded insulation jacket to expose the bare wires.

---

**NOTE:** One wire should already be bare.

---

3. Install the cable wires to a 9-pin D-connector according to directions provided by the connector vendor.

---

**NOTE:** Install the wire without insulation to pin #5 of the 9-pin D-connector. Install the wires with the color-coded insulation to pins #3 and #8. It does not matter which wire is installed to pin #3 or #8, but all connectors must be installed identically. See Figure 4-3 for pin-out information.

---

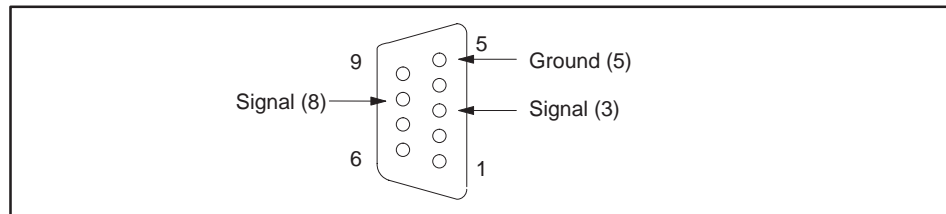

Figure 4-3 9-Pin I/O Female D-Connector Pinout

- 
4. Strip back 1.50 in. (3.8 cm) of the sleeving on the other end of the cable.
  5. Remove 0.13 in. (0.33 cm) of each color-coded insulation to expose the bare wires.
  6. Install each wire end onto a terminal lug according to directions provided by the vendor.

---

**NOTE:** The size of the terminal lug depends on the type of terminal block used. Consult your vendor for the appropriate terminal lug size.

---

### Connecting a CPU Drop Line

Use the following procedure to connect a drop line cable between the programmable controller and terminal block.

1. Ensure that the cable has been prepared as described on page 4-8.
2. Plug the cable D-connector onto the CPU I/O connector.
3. Tighten two cable connector screws to secure the cable D-connector to the CPU I/O connector.
4. Loosen three terminal screws on the terminal block and install the cable lug terminals onto the terminal block. See Figure 4-4.

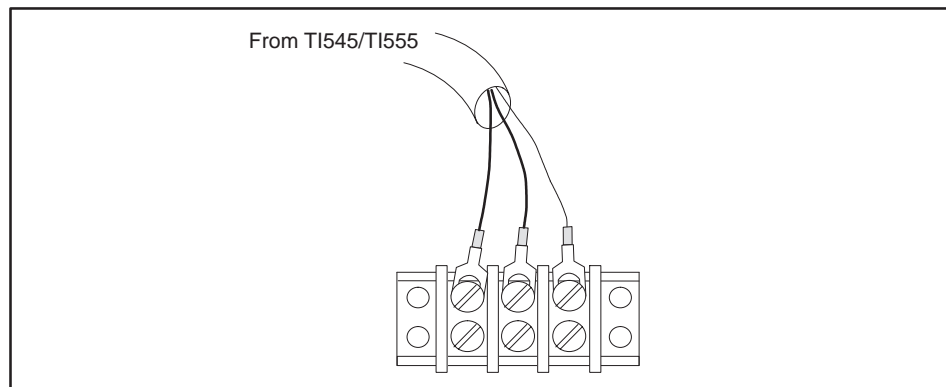

Figure 4-4 Connecting to Terminal Block

5. Tighten terminal block screws.

## Installing Remote I/O Cables (continued)

---

6. If you are not using another terminal block, install a terminating resistor across the terminal screws securing the cable wires with the colored coded insulation jacket. See Figure 4-5.

---

**NOTE:** The terminating resistor value depends on the type of cable being used. See Table 4-1.

---

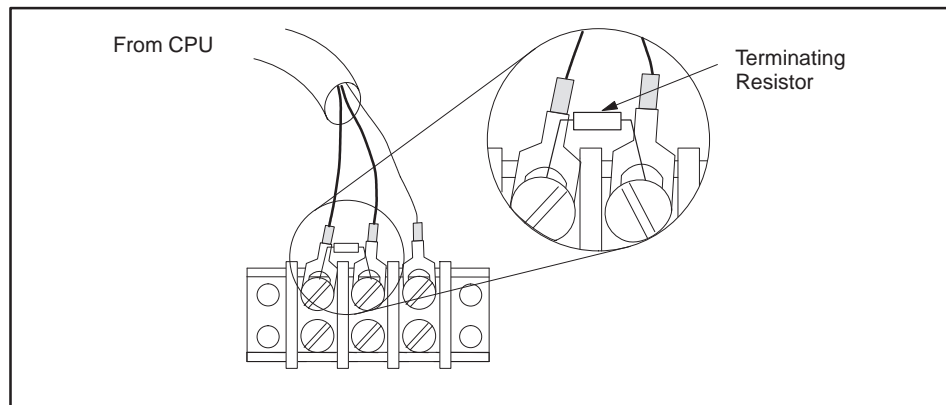

Figure 4-5 Adding a Terminating Resistor

Table 4-1 Terminating Resistors

Cable Type	Resistor Value	Color Code
9860	120 Ohms	Brown-Red-Brown-Gold
9271	120 Ohms	Brown-Red-Brown-Gold
9182	150 Ohms	Brown-Green-Brown-Gold

---

**Connecting the RBC Drop Line**

Use the following procedure to connect a cable between the RBC and terminal block.

1. Prepare another cable as described on page 4-8.
2. Place the cable D-connector onto the RBC RS-485 connector.
3. Tighten two cable connector screws to secure the cable D-connector to the RBC RS-485 connector.
4. Loosen three terminal screws on the terminal block and install the cable terminal lugs onto the terminal block. See Figure 4-6.

---

**NOTE:** Ensure that the RBC cable wires match with the CPU cable wires at the terminal block. For example, if a wire at a bottom terminal screw is blue, the wire directly above it must also be blue.

---

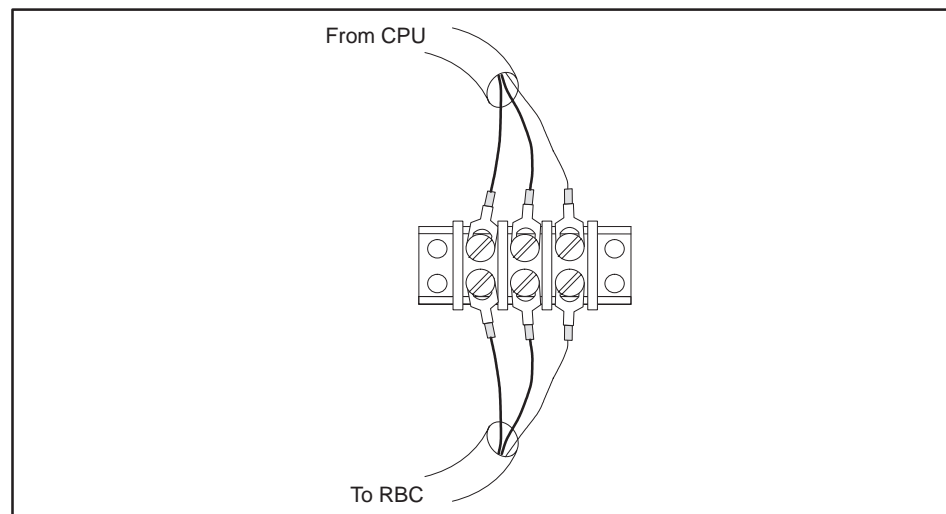

**Figure 4-6 Attaching RBC to Terminal Block**

## Installing Remote I/O Cables (continued)

---

### Connecting Terminal Block Trunk Lines

The cable that connects the terminal blocks is called a trunk line. See Figure 4-2. The maximum trunk length depends on the cable type and number of terminal blocks used in your installation. See Table 4-2.

Table 4-2 Maximum Cable Length for Trunk Lines

Number of Terminal Blocks	Maximum Distance in Feet (Meters)* (Belden Cables)		
	9860 cable	9271 cable	9182 cable
2 – 5	3300 (1006)	1100 (335)	2200 (670)
6	3200 (975)	1067 (325)	2133 (650)
7	3100 (945)	1033 (315)	2067 (630)
8	3000 (914)	1000 (305)	2000 (610)
9	2900 (884)	967 (295)	1933 (589)
10	2800 (853)	933 (284)	1867 (569)
11	2700 (823)	900 (274)	1800 (548)
12	2600 (792)	867 (264)	1733 (528)
13	2500 (762)	833 (254)	1667 (508)
14	2400 (732)	800 (244)	1600(488)
15	2300 (701)	767 (234)	1533 (467)
16	2200 (671)	733 (223)	1467 (447)
17	2100 (640)	700 (213)	1400 (427)

\*Figures in parentheses indicate distance in meters.

---

**NOTE:** Cable types 9860 and 9271 can be mixed on the trunk line, but cable type 9182 must be used alone.

---

---

## Alternate Cables

Three commercially available cables provide an acceptable level of I/O communication in an industrial environment when used in accordance with Table 4-2.

- Belden cable 9860 is a large conductor cable that provides a low attenuation and distortion for long trunk lines.
- Belden cable 9271 is a smaller and more flexible cable suitable for short trunk lines and all drop line cables.
- Belden cable 9182 provides an intermediate level of size, flexibility, and useful length. The 9182 cable is also available in a version (89182) rated for a higher level of fire resistance and low smoke producing properties.

Alternate cables should have a specified characteristic impedance between 100 and 150 ohms; 124 ohms being optimum. Other considerations for alternate cables include: a high uniform twist and spacing of conductors (usually found in cables called “twinaxial”), shield coverage approaching 100%, DC resistance of the installed cable length smaller than the characteristic impedance, and a jacket suitable for the installation.

Characteristics of the cables listed in Table 4-2 are provided in Table 4-3 as a guide for selecting alternate cables.

Table 4-3 Cable Characteristics

<b>Belden Cable Type</b>	<b>Center Conductor</b>	<b>Outside Diameter</b>	<b>Impedance</b>	<b>Capacitance</b>	<b>Velocity</b>
9860	16 AWG solid 13.8 ohm/km	11.18 mm	124 ohms	35.8 pf/m	0.78 c
9271	25 AWG 7x33 104.3ohm/km	6.15 mm	124 ohms	40 pf/m	0.66 c
9182 (89182)	22 AWG 19x34 46 ohm/km	8.89 mm	150 ohms	28.9 pf/m	0.78 c

## Installing Remote I/O Cables (continued)

### Configuration Requirements

Follow these guidelines when installing RS-485 trunk line cabling.

- Measure the maximum length (listed in Table 4-2) from the CPU to the most distant tap. See Figure 4-7.

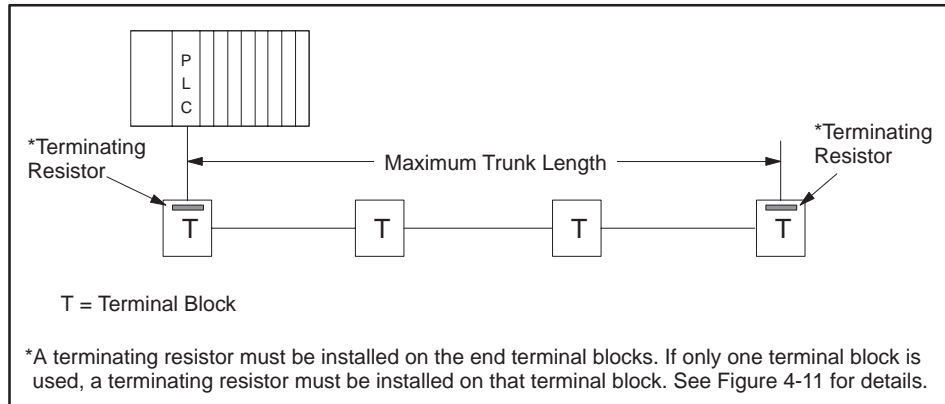

Figure 4-7 Maximum Trunk Length

- By using a T configuration (Figure 4-8), you can increase the total trunk line length to twice the length specified in Table 4-2.

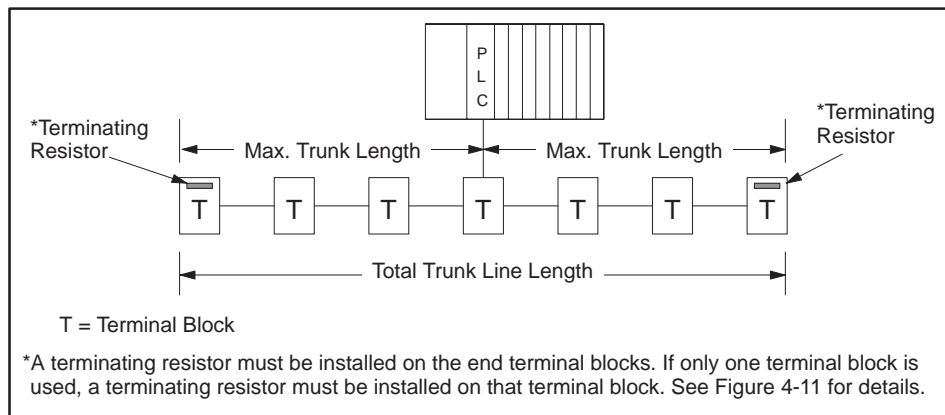

Figure 4-8 T Configuration

- Drop lines should be no longer than 10 m (33 feet).
- Short drop lines of 1 m (3.3 feet) do not measurably affect signal quality and do not have to be counted for the length reduction shown in Table 4-2.



- Where several connections need to be made close together, it is better to place a single terminal block in the trunk line and connect all nearby equipment to that terminal block (Figure 4-9).

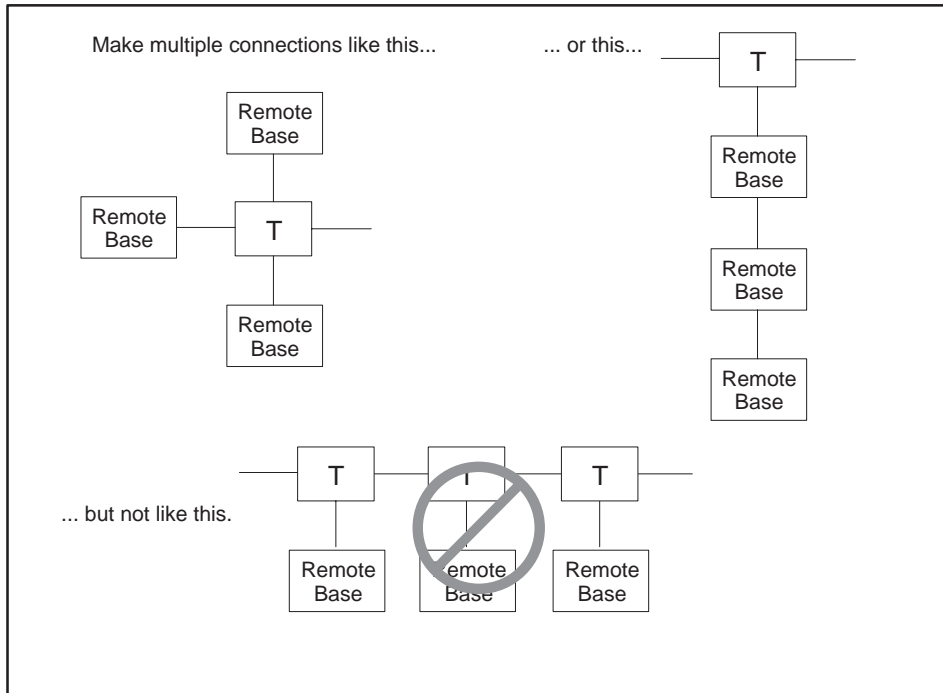

Figure 4-9 Multiple Tap Connections in Close Proximity

- Tap connections on the trunk line should be spaced, on average, so that the total length of trunk cable separating several taps is greater than the sum of the total length of drop cables connected at the taps (Figure 4-10).

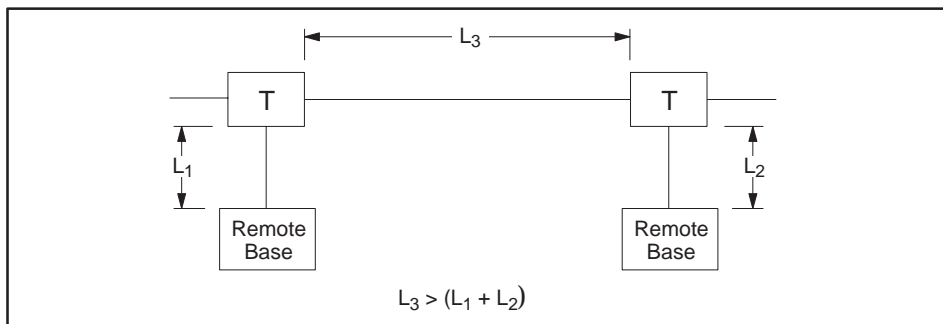

Figure 4-10 Spacing between Taps

## Installing Remote I/O Cables (continued)

---

- The ideal cable installation is a single, unbranched trunk line with short drop cables and a termination resistor at each end of the trunk.

---

**NOTE:** For installations with five connections or less that have a cable length between the controller and the most distant RBC less than 30m (100 feet), any cable configuration can be used. Always use at least one termination resistor, even with the simplest installation.

---

### Preparing Trunk Line Cables

Use the following procedures to prepare trunk-line cables for connecting terminal blocks.

1. Strip back 1.50 in. (3.8 cm) of the sleeving on both ends of the cable.

---

**NOTE:** You will see three wires when the sleeving is stripped back. Two wires have color coded insulation jackets and one is bare.

---

2. Remove 0.13 in. (0.33 cm) of each color-coded insulation jacket (both ends) to expose the bare wires.

---

**NOTE:** One wire is already bare.

---

3. Install each wire (both cable ends) onto a terminal lug according to directions provided by the vendor.

---

**NOTE:** The size of the terminal lug depends on the type of terminal block used. Consult your vendor for the appropriate terminal lug size.

---

---

## Connecting Trunk Line to Terminal Blocks

Use the following procedures to connect two terminal blocks. See Figure 4-11.

1. Loosen three terminal screws on terminal block A and install second set of cable terminal lugs onto the terminal block.

---

**NOTE:** Ensure that the wires of the second set of terminal lugs match with those of the first set of terminal lugs. For example, if a wire at a terminal screw is blue, the second wire installed with it on the same terminal screw must also be blue.

---

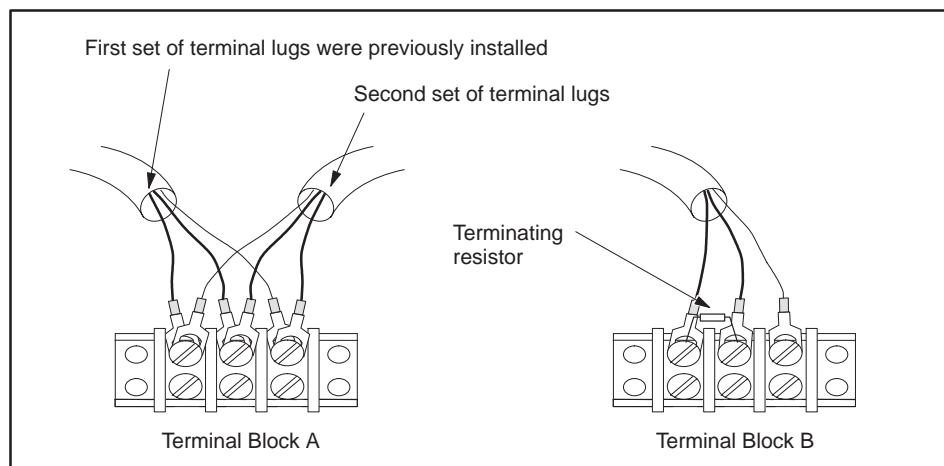

Figure 4-11 Connecting Terminal Blocks

2. Tighten screws on terminal block A.
3. Loosen three screws on terminal block B.
4. Install the terminal lugs on the other cable end to the terminal screws in terminal block B.
5. Tighten screws on terminal block B.
6. If you are not using another terminal block, install a terminating resistor across the terminal screws that secure the cable wires with the colored coded insulation.

---

**NOTE:** The terminating resistor value depends on the type of cable being used; see Table 4-1. A terminating resistor must be installed on the end terminal blocks.

---

Refer to Chapter 7 for procedures to check for faulty cables.

## 4.4 Connecting Modems

### Overview

The CPU can communicate through Port 1 to an operator interface via dedicated line or dial-up phone modems. Dedicated line operation is a line used exclusively to connect the modems. Dial-up phone operation connects the modems by telephone lines. Refer to Figure 4-12 for a typical configuration.

---

**NOTE:** The modems must provide an EIA RS-232C DCE interface to the TI545/TI555 controller and operator interface and must have a built-in V.32 error correction capability.

Although the TI545 and TI555 controllers support both full- and half-duplex communications, TISOFT only supports full-duplex communications.

---

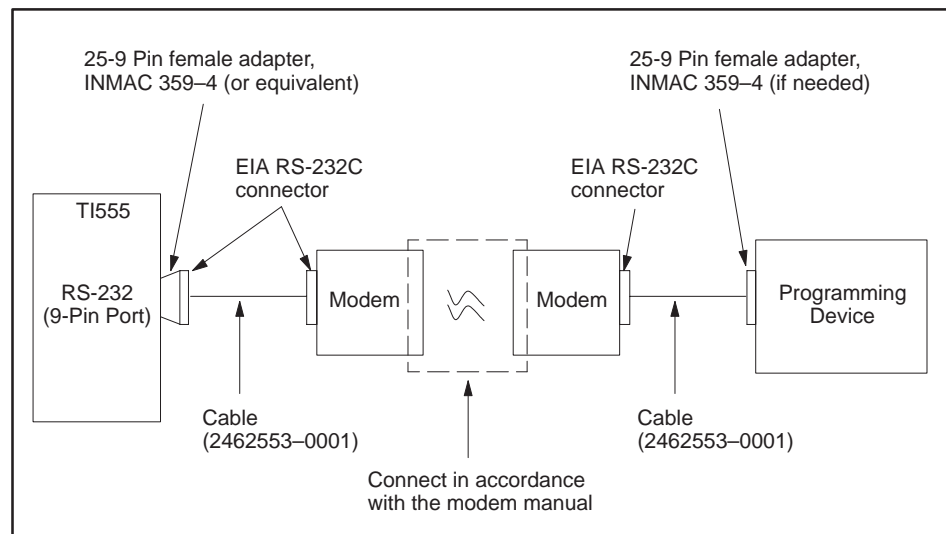

Figure 4-12 Modem Configuration

---

**Dedicated Line Operation**

Use these procedures to establish communication between modems in a dedicated line configuration.

1. Connect the modem configuration.
2. Ensure that the CPU controller and modem baud rates are set to the same value.

---

**NOTE:** If the modems are auto-bauding, ensure that the controller baud rate is set within the baud rate range of the modems.

---

3. Power up the modems and verify that they are connected—usually by an indicator on the modems.
4. Execute TISOFT; TISOFT auto-bauds to the system's baud rate (CPU and modem).

**Dial-up Phone Line Operation**

Use these procedures to establish communication between modems in a dial-up phone line configuration.

1. Connect the modem configuration.
2. Ensure that the CPU controller and modem baud rates are set to the same value.
3. Depending on the type of modems being used, the following are three ways to establish communication between the modems.
  - Manually call from one modem station to the other modem station and then switch on both modems.
  - Manually call from one modem station to an auto-answer modem at the other station.
  - Use TIDIAL dialing software installed with TISOFT Release 5.0 to call an auto-answer modem at the PLC modem station.
4. Execute TISOFT; TISOFT auto-bauds to the system's baud rate (CPU and modems).

## 4.5 Connecting a Printer

### Overview

The CPU has the capability to send information to a printer through the use of an SF program or SF subroutine. The printer connects to Port 1 and uses RS-232 protocol. Cabling for the two available handshaking options are as follows:

- XON/XOFF printer handshaking; see Figure 4-13.
- READY/BUSY printer handshaking; see Figure 4-14.

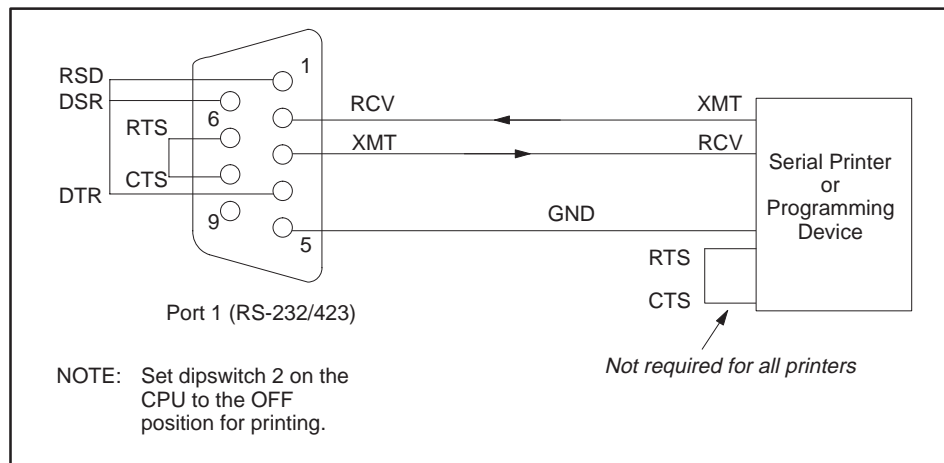

Figure 4-13 XON/XOFF Printer Handshaking

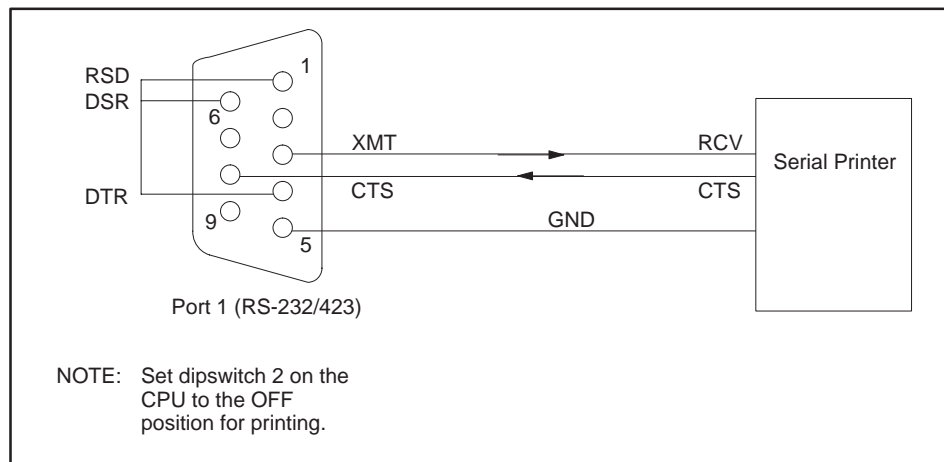

Figure 4-14 READY/BUSY Printer Handshaking

# Using an EEPROM or EPROM

---

<b>5.1</b>	<b>Introduction</b> .....	<b>5-2</b>
	Program Storage .....	5-2
	Using an EEPROM .....	5-2
	Using an EPROM .....	5-3
	EEPROM Functions .....	5-4
<b>5.2</b>	<b>TI545/TI555 Memory and Mode Status at Power-up</b> .....	<b>5-5</b>
<b>5.3</b>	<b>Installing EEPROMs and EPROMs</b> .....	<b>5-6</b>
<b>5.4</b>	<b>Copying a Program into an EEPROM</b> .....	<b>5-8</b>
<b>5.5</b>	<b>Editing a Program Stored in EEPROM</b> .....	<b>5-10</b>

## 5.1 Introduction

---

### Program Storage

The CPU offers the option of storing your application program in non-volatile form. Using Electrically Erasable Programmable Read-Only Memory (EEPROM), or Erasable Programmable Read-Only Memory (EPROM [UV-EPROM]), is discussed in the following sections. See Table 5-1 for a description of available EEPROMs and EPROMs.

Table 5-1 Program Storage Using EEPROM and EPROM

Storage Type	Size	Order Number
EEPROM	128K bytes	2587681-8022
EEPROM	256K bytes	2587681-8030
EPROM	128K bytes	2587681-8023
EPROM	256K bytes	2587681-8031

After your EEPROM has been programmed, it is portable; that is, it can be used in any other TI545-1102 or TI555 controller.

### Using an EEPROM

If you install an EEPROM, the CPU allows you to save your current program without using a separate EEPROM programming device. The program can be downloaded directly from RAM to a 128K byte or 256K byte EEPROM by using Auxiliary Function 84. Complete instructions on storing a program using an EEPROM appear later in this chapter. Refer to Table 5-2 for EEPROM compatibility.

Table 5-2 EEPROM/EPROM Portability Between Controllers

Controller/Firmware Release	Can Use EEPROM/EPROM From:
TI545-1102* or TI555 with Firmware Release 3.0 or later.	TI545, TI555 with any firmware release.
TI555 with Release 1.1.2. or earlier.	TI545-1101 with any firmware release. TI555 with Release 1.1.2 or earlier.
Note: * Due to the inclusion of password-related information in the (E)EPROM, an EEPROM generated by Release 3.0 or later on the TI545-1102 or TI555 cannot be used in the TI545-1101. If you require an (E)EPROM for use on the both the TI545-1101 and the TI545-1102 (TI555), create the EEPROM on the TI545-1101.	



---

The EEPROM stores the user program including the following:

- Relay ladder logic (RLL).
- K memory.
- U memory.
- S memory (PID loops, analog alarms, and SF programs).
- Memory configuration.
- I/O configuration.
- Password , if installed.
- Scan configuration.

After storage in the EEPROM, this data is saved even if power is cycled without a backup battery. However, other data in memory will be lost if you do not have a backup battery.

---

**NOTE:** To help ensure that the data listed above is saved, the total user memory space to be stored in the EEPROM must not exceed 126K bytes or 254K bytes. If the total user memory (not system memory) space occupied by these areas is greater than 126K bytes or 254 K bytes, no data is saved. The error message, **OPERATION FAILED**, is displayed on the screen if the user memory exceeds the applicable size when attempting to save the data.

---

#### Using an EPROM

If your operating program does not change, you can store it permanently on an EPROM. You can use an EPROM copier to copy your program from an EEPROM to an EPROM. (The EPROM cannot be programmed in the CPU.) This is a cost-effective method for creating duplicate copies if you have additional CPUs running the same program.

## Introduction (continued)

---

**EEPROM Functions** After your EPROM has been programmed, it is portable and can be used in any other TI545–1102 or TI555 CPU of compatible or newer software revision. EPROMS are available from your distributor for EPROM applications.

You can manage operation of EEPROMs by using AUX Function 84 on your programming unit. If necessary, refer to your *SIMATIC TI505 Programming Reference* manual for detailed instructions about executing AUX Functions. AUX Function 84 allows you to do the following procedures:

- Copy RAM to EEPROM.
- Copy EEPROM to RAM.
- Select RAM as program source.
- Select EEPROM as program source.
- Erase the program in EEPROM.
- Report source (RAM OR EEPROM) of program being executed.

---

**NOTE:** The EEPROM is automatically write protected on power up, which helps to prevent any accidental write operations.

---

## 5.2 TI545/TI555 Memory and Mode Status at Power-up

---

When you power up a TI545/TI555 system, the CPU checks the status of the EEPROM (EPROM) and the battery. A clear (un-programmed) EEPROM (EPROM) is equivalent to having no EEPROM (EPROM) installed. Table 5-3 lists mode and memory status (after power up) that result from various battery and EEPROM (EPROM) conditions.

Table 5-3 TI545/TI555 Mode and Memory Status After Power-up

Conditions		Results	
Battery Status	Programmed EEPROM (or EPROM) Installed and Selected	Controller Memory	Controller Mode
Bad or Off	No	Cleared	PROGRM
Bad or Off	Yes	Cleared, then loaded with program that is in EEPROM (EPROM)	RUN
Good and On	No	No change	Mode prior to power loss
Good and On	Yes (same program)	No change	Mode prior to power loss
Good and On	Yes (different program)	Cleared, then loaded with program that is in EEPROM (EPROM)	RUN

## 5.3 Installing EEPROMs and EPROMs

---

Follow instructions in this section to install an EEPROM or EPROM in your CPU.

---

**NOTE:** If you are installing an EEPROM and intend to download a program (from RAM memory), ensure that the good back-up battery is fully charged and enabled. Controller power must be turned off and, without a functioning back-up battery, your program may be lost when power is restored.

---

1. Place the CPU in PROGRAM Mode. You may want to use TISOFT AUX 60 (SAVE PLC → ALL) to save program to disk before proceeding.
2. Ensure that switch 9 on the CPU dipswitch is turned On (to the left). This enables backup battery.
3. Turn off all user-supplied power to the TI545/TI555 base.

### CAUTION

---

**Electrostatic discharge can damage the CPU.**

**Personnel must make contact with a grounded conductive pad and/or wear a grounded wrist strap when handling the CPU.**

---

4. Remove the CPU from the base assembly and place component-side up on a non-conductive surface.
5. Insert the EEPROM (EPROM), aligning the notches on the EEPROM (EPROM) and the socket (Figure 5-1).
6. Check the pins to make sure that they are all seated properly in the socket.
7. Observe Jumper E18. If you intend to write to the EEPROM, ensure that Jumper E18 is strapped. If you do not write to the EEPROM and want to disable this feature, remove strap E18.
8. Re-install the CPU in the base and turn the base power On. Refer to the Troubleshooting chapter if the EEPROM (EPROM) fails to function correctly.

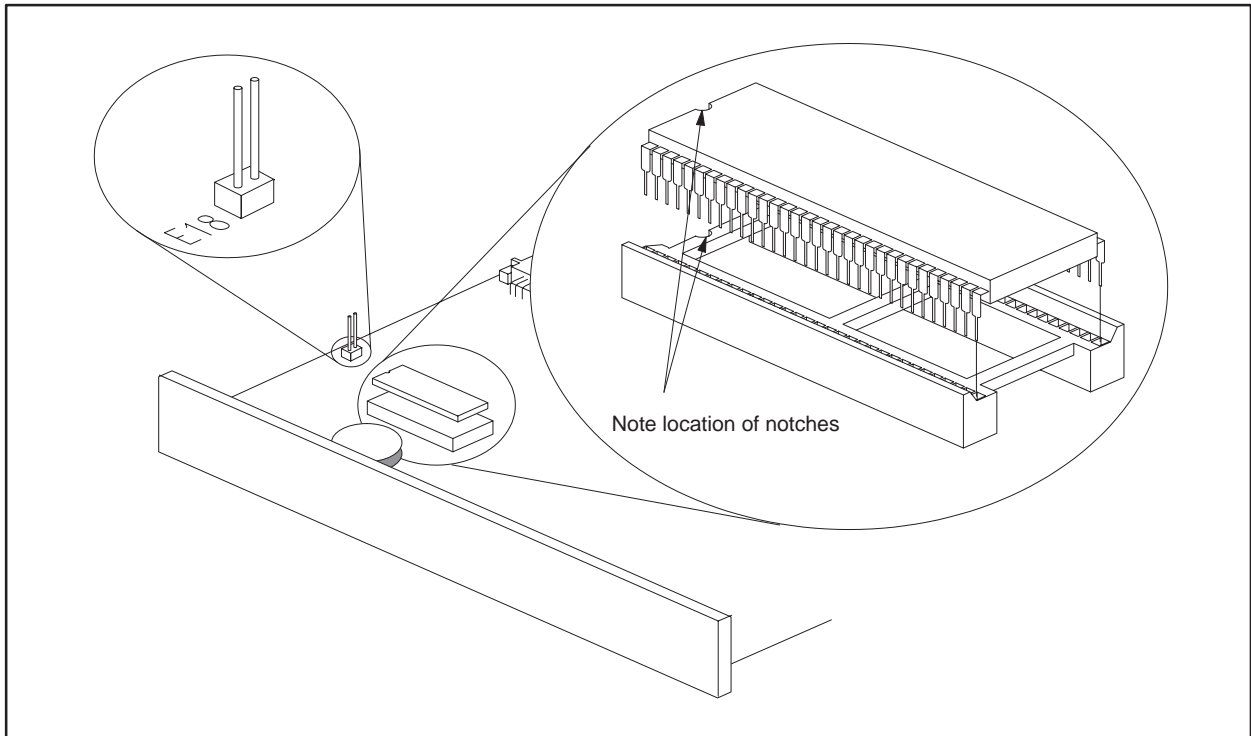

Figure 5-1 EPROM (EPROM) Socket and Jumper Pins

## 5.4 Copying a Program into an EEPROM

---

To copy a program into your EEPROM, you must first enter the program into the CPU. Verify that your program is correct, save your program to your programming unit hard disk, and then continue with the steps listed below.

1. Ensure that the battery enable dipswitch is On, and that jumper pins (E18) are strapped to enable programming.
2. Set the CPU to PROGRAM mode.
3. Select Auxiliary Function 84 in your programming unit.
4. Use the Source Toggle option to select RAM as your program source.
5. Use the AUX Function 84 to erase program data on the EEPROM.
6. Use the Copy option to copy the program from RAM to the EEPROM.

---

**NOTE:** The CPU does not allow changes to program memory during the programming of the EEPROM.

---

The CPU returns to the PROGRAM mode when the copy process is completed.

7. If you are finished copying the program, go to step 8.

To copy the program to another EEPROM, turn off controller power, replace the EEPROM with another, and power up again. Repeat Steps 5 and 6 to copy the program to another EEPROM; continue the process to program additional EEPROMs.

---

### **WARNING**

**To minimize risk of potential injury to personnel or damage to equipment check the program before permitting a CPU to execute from an EEPROM program.**

**An incorrect program can cause death or serious injury and/or damage to equipment.**

**You must be absolutely certain that the EEPROM program is correct. Take standard precautions associated with program development and debug.**

---

- 
8. If the program is correct and you want to run the program from EEPROM, use the Source Toggle option to select EEPROM as the program source.

 **WARNING**

---

**Electronic devices can operate in an unsafe condition that can cause death or serious injury and/or damage to equipment.**

**When you select EEPROM, the controller is cleared and then loaded with the EEPROM content. This clears V-memory and resets all timers, counters, and drums, etc.**

**Be sure that you really want to select EEPROM.**

---

9. Use AUX 17 to check the program carefully, while the CPU is in the PROGRAM mode, before allowing the CPU to control equipment connected to the I/O.

If an error occurs during the copy process it will be listed on the programming unit. If an error occurs, perform the following checks:

- Ensure that the EEPROM jumper pin programming enable strap is installed correctly.
- Ensure that an EEPROM, not an EPROM, is installed.
- Ensure that all EEPROM pins are properly seated in the socket.

Other possible causes for errors include the following:

- The EEPROM may be defective.
- The EEPROM may already have been programmed (and not erased). Use the AUX Function 84 to erase program data on the EEPROM.
- The size of your user program that is being stored may exceed the size of the installed EEPROM (126K bytes or 254K bytes).

If you suspect a defective EEPROM, power down, remove the EEPROM, install another EEPROM, power up again and repeat the programming procedure.

## 5.5 Editing a Program Stored in EEPROM

---

You can edit the program and data stored in an EEPROM by following the steps listed below.

---

NOTE: If necessary, refer to your *SIMATIC TI505 Programming Reference* manual for detailed instructions about executing AUX Functions.

---

1. Using your programming unit and the AUX Function 84 option, select EEPROM as the program source. This will copy the EEPROM program to RAM.

### WARNING

---

**Electronic devices can operate in an unsafe condition that can cause death or serious injury and/or damage to equipment.**

**When you select EEPROM, the controller is cleared and then loaded with the EEPROM content. This clears V-memory and resets all timers, counters, and drums, etc.**

**Be sure that you really want to select EEPROM.**

---

2. Select RAM as the program source.
3. Edit the program source code (in RAM memory) as required.
4. Use the AUX Function 84 to erase program data on the EEPROM.
5. Copy the RAM program back to EEPROM.
6. Select the EEPROM as the program source.

Although the CPU can copy a program from either an EEPROM or an EPROM into RAM, the CPU cannot copy a program from RAM to an EPROM.

---

NOTE: AUX Function 84 will not download timer/counter and drum/event presets, and values in V-memory.

---



# Starting Up the TI545/TI555 System

---

<b>6.1</b>	<b>Powering Up the TI545/TI555 System</b> .....	<b>6-2</b>
	Overview .....	6-2
	Start-up Procedures .....	6-2
<b>6.2</b>	<b>TI545 CPU Memory Configuration</b> .....	<b>6-4</b>
	Memory Configuration .....	6-4
	Maximum Configurable Memory .....	6-4
<b>6.3</b>	<b>TI555 CPU Memory Configuration</b> .....	<b>6-5</b>
	Memory Configuration .....	6-5
	Maximum Configurable Memory .....	6-5

## 6.1 Powering Up the TI545/TI555 System

---

**Overview** This section provides general guidelines for powering up your TI545/TI555 system system.

### **WARNING**

---

**You must be fully informed about safety procedures before you power up the TI545/TI555 system.**

**Not knowing so could result in death or serious injury and/or damage to equipment.**

**Review and comply with safety procedures listed in Chapter 2 before completing the following steps.**

---

### **Start-up Procedures**

Follow these procedures when powering up your TI545/TI555 system for the first time.

1. Be familiar with the operation of your system components.
2. Verify the following items.
  - Power Supply PPX:505-6660 requires 110 or 220 VAC input power.
  - If any of your installed 505 bases have empty I/O slots, use filler bezels (part #2587705-8003) and bezel screws (part #2587705-8001) to cover the openings in the base. This prevents debris from getting into the system; it also helps prevent electrostatic discharge and other types of electrical noise interference.
  - After installation is complete, remove the plastic dust guard on the top grill of every installed Series 505 base.

### **WARNING**

---

**You must remove the dustguard from the base.**

**Failure to remove the dustguard may result in overheating and damage to equipment.**

**This could result in death or serious injury and/or damage to equipment.**

---

- Check for correct switch settings on all configurable modules, e.g., the programmable controller and RBC(s). The jumper strap (E18) on the CPU must be strapped if you intend to copy user programs into an installed EEPROM.
- Ensure that all modules are securely plugged into the base(s), connector pins are not bent, and bezel screws are tightened.

- 
- Check AC input power for proper voltages. Ensure that the jumper in the back of the power supply is set for the correct voltage.
  - Ensure that all I/O interface cables are properly connected to I/O interface connectors.
  - Ensure that all configured bases are properly connected, there are no crimps or breaks in the cable, and base addresses are correct.
3. If you intend to use an EEPROM (EPROM), install the EEPROM (EPROM) according to the instructions given in Chapter 5.
  4. Initialize the CPU by completing the following procedures:
    - If you have not already done so, disable the CPU battery by turning off switch 9 on the dipswitch. Ensure that a programmed EEPROM (EPROM) is not installed.
    - Turn on power to the controller.
    - With the battery disabled and no programmed EEPROM (EPROM) installed, the CPU clears memory and enters PROGRAM mode.
    - Enable the battery backup circuit by turning on switch 9. The Battery Good LED should light. The CPU is now initialized.

---

**NOTE:** If the battery LED does not come on, the battery may be discharged. The LED should light when fully charged with the switch enabled and power applied. A blinking light means marginal charge. The battery will be fully charged after 24 hours of operation.

---

5. Connect your programming device to one of the CPU communication ports. Place the CPU in PROGRAM mode. If you have installed a pre-programmed EEPROM (EPROM), go to step 8.
6. Using your programming device, enter the memory (refer to Table 6-1 and Table 6-2) and I/O configuration.
7. Enter the user program. See the *SIMATIC TI505 Programming Reference Manual* (PPX:505–8104) for programming information.
8. Use your programming device to JOG motors, solenoids, or other positioning devices one at a time to establish correct rotation or positioning.

After all the steps are performed and verified, place the controller in RUN mode.

## 6.2 TI545 CPU Memory Configuration

### Memory Configuration

The TI545 CPU memory is user configurable. The actual ranges of memory types depend upon how the memory has been configured. Ranges for memory types are listed in Table 6-1.

You can increase the memory allocated to a particular memory type, a block at a time, up to the maximum listed in Table 6-1. Block sizes vary with the memory type as shown in Table 6-1.

Some overhead is associated with certain memory types. For example, each K byte of L-memory uses a total of 3K bytes of system memory. Each timer/counter uses 5 bytes of system memory. A drum uses 48 bytes.

When you increase L-memory by one block, from 16K bytes to 20K bytes, system memory reserved for L-memory increases from 48K bytes to 60K bytes. When you increase the number of drums by one block, from 64 to 128, system memory reserved for drums increases from 3K bytes to 6K bytes.

### Maximum Configurable Memory

Up to 192K bytes of configurable system memory are available on the TI545 CPU. You cannot configure all memory types to their maximum allocation size simultaneously. For example, if V-memory is configured to 177K bytes, then S memory cannot be configured to 176K bytes because the 192K bytes of system memory would be exceeded.

Refer to your TISOFT manual and *SIMATIC TI505 Programming Reference* manual for additional information on memory configuration and configuring I/O.

Table 6-1 TI545-1102 CPU Memory Configuration

Memory Type	Block Allocation Size	Memory Required per Block	Minimum Size	Maximum Size	Total Memory Required for Maximum Size
Ladder (L)	1K bytes	3K bytes	1K bytes	59K bytes	177K bytes
Variable (V)	1K bytes	1K bytes	1K bytes	177K bytes	177K bytes
Constant (K)	1K bytes	1K bytes	0K bytes	176K bytes	176K bytes
Special (S)	1K bytes	1K bytes	0K bytes	176K bytes	176K bytes
User (U)	1K bytes	1K bytes	0K bytes	176K bytes	176K bytes
Timer	1024*	5K bytes	1024*	4096	20K bytes
Drum	64*	3K bytes	64	512	24K bytes
Shift Register	1024*	1K bytes	1024*	3072	3K bytes
Table Move	1024*	2K bytes	1024*	3072	6K bytes
One Shot	1024*	1K bytes	1024*	7168	7K bytes

\*Number per block.

## 6.3 TI555 CPU Memory Configuration

### Memory Configuration

The TI555 CPU memory is user configurable. The actual ranges of memory types for each model of the CPU depend upon how the memory has been configured. Ranges for memory types are listed in Table 6-2.

You can increase the memory allocated to a particular memory type, a block at a time, up to the maximum listed in Table 6-2. Block sizes vary with the memory type as shown in Table 6-2.

Some overhead is associated with certain memory types. For example, each K-byte of L-memory uses a total of 3K bytes of system memory. Each timer/counter uses 5 bytes of system memory. A drum uses 48 bytes. When you increase L-memory by one block, from 16K bytes to 20K bytes, system memory reserved for L-memory increases from 48K bytes to 60K bytes. When you increase the number of drums by one block, from 64 to 128, system memory reserved for drums increases from 3K bytes to 6K bytes.

### Maximum Configurable Memory

Up to 384K bytes of system memory are available on the PPX:555-1101 CPU, and up to 1920K bytes on the PPX:555-1102 CPU. You cannot configure all memory types to their maximum allocation size simultaneously. For example, (for the TI555-1101) if you configure V-memory to 369K bytes, then you cannot configure S-memory to 368K bytes because the 384K bytes of system memory would be exceeded.

Refer to your TISOFT manual and *SIMATIC TI505 Programming Reference* manual for additional information on memory configuration.

Table 6-2 TI555-1101/1102 CPU Memory Configuration

Memory Type	Block Allocation Size	Memory Required per Block	Minimum Size	Maximum Size		Total Memory Required for Maximum Size	
				-1101	-1102	-1101	-1102
Ladder (L)	1K bytes	3K bytes	1K bytes	123K bytes	635K bytes	369K bytes	1905K bytes
Variable (V)	1K bytes	1K bytes	1K bytes	369K bytes	1905K bytes	369K bytes	1905K bytes
Constant (K)	1K bytes	1K bytes	0K bytes	368K bytes	1904K bytes	368K bytes	1904K bytes
Special (S)	1K bytes	1K bytes	0K bytes	368K bytes	1904K bytes	368K bytes	1904K bytes
User (U)	1K bytes	1K bytes	0K bytes	368K bytes	1904K bytes	368K bytes	1904K bytes
Timer	1024*	5K bytes	1024*	20480	20480	100K bytes	100K bytes
Drum	64*	3K bytes	64*	2304	2304	108K bytes	108K bytes
Shift Register	1024*	1K bytes	1024*	16384	16384	16K bytes	16K bytes
Table Move	1024*	2K bytes	1024*	14336	14336	28K bytes	28K bytes
One Shot	1024*	1K bytes	1024*	32768	32768	32K bytes	32K bytes

\*Number per block.

# Chapter 7

## Troubleshooting

---

<b>7.1</b>	<b>Troubleshooting by Using Auxiliary Functions</b> .....	<b>7-2</b>
	Overview .....	7-2
	Power-up Restart, Partial Restart, and Complete Restart .....	7-2
	Compare PLC to Disk .....	7-4
	Run PLC Diagnostics .....	7-4
	Display Failed I/O .....	7-4
	Show PLC Diagnostic Cell .....	7-4
<b>7.2</b>	<b>Troubleshooting by Reading LEDs</b> .....	<b>7-6</b>
<b>7.3</b>	<b>Troubleshooting Controller Fatal Errors</b> .....	<b>7-7</b>
	CPU Fatal Error Indications .....	7-7
	Causes of CPU Fatal Errors .....	7-7
	Controller Responses to Fatal Errors .....	7-7
	Steps to Clear Fatal Errors .....	7-8
	Calling for Assistance .....	7-8
<b>7.4</b>	<b>Troubleshooting Controller Non-Fatal Errors</b> .....	<b>7-9</b>
<b>7.5</b>	<b>Troubleshooting by Using Status Words</b> .....	<b>7-10</b>
<b>7.6</b>	<b>Troubleshooting EEPROMs or EPROMs</b> .....	<b>7-11</b>
<b>7.7</b>	<b>Troubleshooting the Power Supply</b> .....	<b>7-12</b>
<b>7.8</b>	<b>Checking RS-485 (Twisted Pair) Cable Installation</b> .....	<b>7-14</b>
	Using Digital or Analog Meter .....	7-14
	Resistance Below Minimum .....	7-15
	Resistance Above Maximum .....	7-15
<b>7.9</b>	<b>Recommended Spare Parts List</b> .....	<b>7-16</b>

## 7.1 Troubleshooting by Using Auxiliary Functions

---

### Overview

The TI545/TI555 CPU has self-checking and diagnostic capabilities that can be used for troubleshooting purposes. The diagnostics and self-checks are accessible through the Auxiliary Function menu on your programming device.

When you display the Auxiliary Function menu, the following functions are available for resetting the CPU, initiating diagnostics or displaying diagnostic information:

- Power-up restart — AUX 10.
- Partial restart — AUX 11.
- Complete restart — AUX 12.
- Compare PLC to Disk — AUX 17.
- Run PLC diagnostics — AUX 20.
- Display failed I/O — AUX 25.
- Show PLC diagnostic cell — AUX 29.

### Power-up Restart, Partial Restart, and Complete Restart

AUX Function 10 (power-up restart), AUX Function 11 (partial restart), and AUX Function 12 (complete restart) are restart/clear functions. See Table 7-1 for AUX Function 10, 11, and 12 restart states.

Table 7-1 Effects of Using AUX Functions 10, 11, and 12

System Characteristic	Power-up Restart AUX 10 Battery		Partial Restart AUX 11 Battery		Complete Restart AUX 12 Battery	
	ON	OFF	ON	OFF	ON	OFF
Controller Mode (RUN, PGM HOLD, RAM, ROM)	No change	Program**	No change*	No change*	No change*	No change*
Loop Processing Mode	No change	Program/ LOCK**	No change*	No change*	No change*	No change*
Loop Mode	No change	N/A	No change	No change	Manual	Manual
Discrete I/O (X's and Y's)	Cleared	Cleared	Cleared	Cleared	Cleared	Cleared
Word I/O (WX's and WY's)	No change	Cleared	No change	No change	Cleared	Cleared
Non-Retentive Control Relays	Cleared	Cleared	Cleared	Cleared	Cleared	Cleared
Retentive Control Relays	No change	Cleared	No change	No change	Cleared	Cleared
Forced Elements	No change	Cleared	No change	No change	No change	No change
TMR/CTR/Drum Presets	No change	Cleared	No change	No change	Downloaded	Downloaded
L, V, K, S, U Memory	No change	Cleared	No change	No change	No change	No change
Memory Configuration	No change	Default value	No change	No change	No change	No change
I/O Configuration	No change	Cleared	No change	No change	No change	No change
Scan Time	No change	Variable	No change	No change	No change	No change
Time of Day	No change	No change	No change	No change	No change	No change
Task Codes/Scan	No change	2	No change	No change	No change	No change
Watchdog Value	No change	1 sec	No change	No change	No change	No change
Port Lockout	No change	Unlocked	No change	No change	No change	No change
Fatal Error	No change	Cleared	Cleared	Cleared	Cleared	Cleared
* If fatal error was present, then Program Mode						
** If programmed EEPROM (EPROM) is present, then Run Mode using program in EEPROM (EPROM)						



## Troubleshooting by Using Auxiliary Functions (continued)

---

Compare PLC to Disk	<p>AUX Function 17 (Compare PLC to Disk) compares program disk and controller data. It allows you to save and load your VERIFY options to and from the disk or directory.</p>
Run PLC Diagnostics	<p>AUX Function 20 (run PLC diagnostics) initiates the CPU self-checks. The CPU must be in PROGRAM mode in order to execute self-tests. The CPU executes the equivalent of an AUX Function 20 at every power up. If any area fails, a message detailing the failure is displayed. AUX Function 20 makes the following tests.</p> <ul style="list-style-type: none"><li>• Valid RAM locations are verified.</li><li>• Pre-coded ROM checksum values are checked.</li><li>• The hardware force function is checked.</li><li>• Internal timer operation is verified.</li></ul>
Display Failed I/O	<p>AUX Function 25 (display failed I/O) displays the locations of any failed I/O modules which are capable of diagnosing and indicating failure. Some modules, such as word and analog modules, report that they have failed if the user-supplied voltage is not correct.</p> <p>AUX Function 25 also displays I/O mismatch(es), indicating that one or more installed module(s) do not agree with the I/O configuration. Verify that the configuration data for listed modules is correct before considering that the module may actually be malfunctioning.</p>
Show PLC Diagnostic Cell	<p>AUX Function 29 checks the operational status of the CPU and displays the results. The display provides the information illustrated in Figure 7-1. Field descriptions are listed below.</p> <ul style="list-style-type: none"><li>• Scan = scan time reported by AUX Function 29; it is the highest scan time recorded since the last CPU reset, PROGRAM-RUN mode transition, or user peak resets. Status Word 10 (STW10) contains a continuously updated report of the scan time.</li><li>• Key = always unlocked; the CPU does not have a key.</li><li>• Mode = Run, Program, or Hold; shows the CPU operating mode.</li><li>• SF/Loop Mode = Run indicates the system is running loops, analog alarms, and SF programs in the SF/Loop Mode.</li></ul>

- SF/Loop Follows PLC to Program Mode — informational comment.
- PLC Fatal Error = a description, causes, and corrective actions are listed in Section 7.3.
- PLC Non-fatal Error = a description, causes, and corrective actions are listed in Section 7.4.
- Loop Fatal Error = status word 161 (STW161) reports the causes and indicates the corrective actions.
- Loop Non-fatal Error = status word 162 (STW162) reports the causes and indicates the corrective actions.
- Battery = On indicates the backup battery is switched On and good; Off indicates the backup battery is switched Off or bad.
- Download select switch is not user accessible and is always Off.
- Program in [RAM or ROM]; RAM if system is operating from RAM memory; ROM if system is operating from an EEPROM (EPROM).

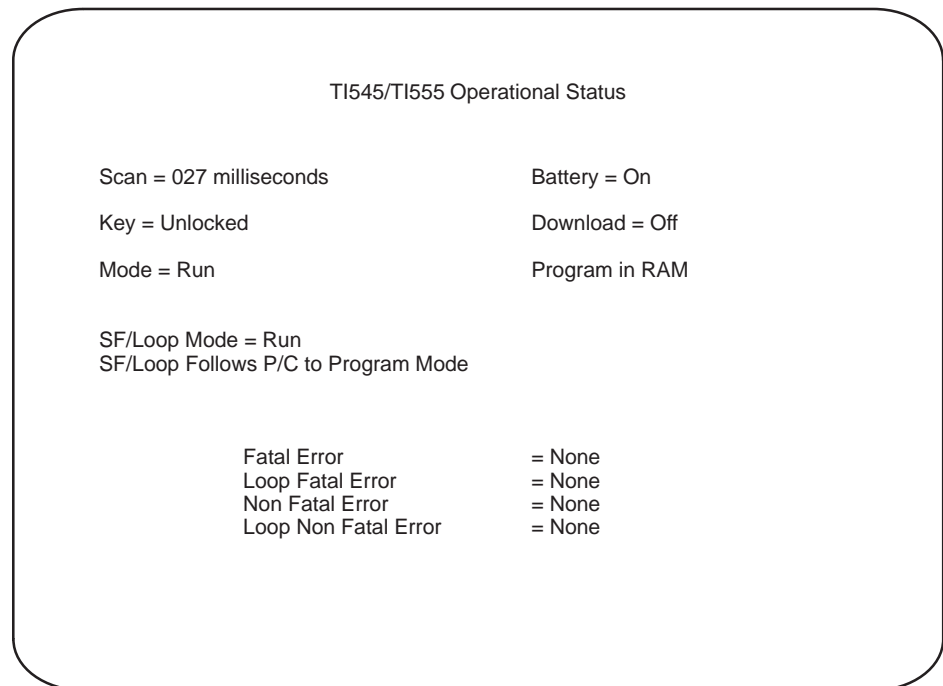

Figure 7-1 Typical AUX Function 29 Screen

## 7.2 Troubleshooting by Reading LEDs

---

Three LEDs on the CPU are labeled CPU GOOD, RUN, and BATT GOOD. These LEDs provide CPU status as shown in Table 7-2.

---

**NOTE:** Since the CPU receives power from the base power supply module, the power supply must be on and functioning correctly to turn the LEDs on. Obviously, if the base power supply module is defective or Off, all CPU indicators will be Off.

---

Table 7-2 CPU Indicators

Indicator	Status	Meaning
CPU GOOD	On	Controller functioning with no fatal errors.
RUN	On	Controller (analog and discrete) is in the RUN mode.
	Flashing	Analog (Loops, Analog Alarms, and SF programs) is in the RUN mode and discrete (RLL program) is in the PROG mode.
BATT GOOD	On	Battery is good and switch 9 is On.
	Flashing	Battery is marginally charged and switch 9 is On.
	Off	Battery is discharged or Switch 9 is Off.

Data in the CPU is backed up by a rechargeable lithium battery. Status of the battery LED is determined as follows:

- When the battery dipswitch is set to the ON position, a 250-ms battery test is initiated within one second. At the end of the test, the battery status LED is updated with the test result.
- While the battery dipswitch is in the ON position, the battery is retested whenever the hour byte of the time-of-day clock changes value. The battery status is reflected by the results of the last completed test.
- When the battery dipswitch is set to the OFF position, battery-low status is indicated within approximately one second.

---

**NOTE:** The situation may occur when the battery dipswitch is on and the battery is marginally charged, i.e., the battery is okay when not under load, but is low when under load. In this case, the battery test is still done hourly, but the battery LED flashes. This indicates that the battery is charging (or discharging, if it was good). While in this state, a power-up restart following a brief power outage will probably result in a battery-good restart.

---

## 7.3 Troubleshooting Controller Fatal Errors

---

### CPU Fatal Error Indications

A fatal error is indicated when both the following conditions are present.

- CPU GOOD LED is not lighted.
- The DC POWER GOOD LED on the power supply is on.

### Causes of CPU Fatal Errors

The CPU enters a fatal error condition and ceases operation if one of the problems listed below occurs. AUX Function 20 or 29 displays the problem that caused the CPU to enter the fatal error condition.

- ROM diagnostic failure — the operating system EPROMs are found to be invalid.
- Watchdog time-out — the microprocessor does not reset a watchdog circuit periodically.
- Illegal operation code — the microprocessor receives an illegal instruction.
- Diagnostic test failure — the CPU fails a diagnostic test.
- Operating system fatal error — the CPU detects a non-recoverable error during execution.
- Abnormal power loss — the CPU detects DC power failure without advance warning from the power supply.
- Dynamic Program Memory Diagnostics Error — the CPU determines a checksum error in the user program memory (ladder or external subroutine)
- Fatal error due to EEPROM (EPROM) — the EEPROM (EPROM) is bad.

### Controller Responses to Fatal Errors

When a fatal error occurs, the CPU attempts the following actions.

- The CPU GOOD LED is turned off.
- I/O ports are disabled, discrete outputs are turned off, and word outputs are held in their last valid state.
- Communication ports are cleared and re-initialized.
- Pending or queued communication tasks are aborted.

## Troubleshooting Controller Fatal Errors (continued)

---

### Steps to Clear Fatal Errors

Attempt to clear the fatal error by following the steps listed below. When the CPU GOOD LED turns on, the fatal error has been cleared.

1. Determine the fatal error condition by selecting AUX Function 29 from the Auxiliary Function Menu on your programming unit. Record the fatal and non-fatal error(s) listed along with the date, time, controller serial number and software part number (AUX 15) for later reference.

---

**NOTE:** Always execute AUX Function 29 and make a list of the errors before attempting to clear them. If you clear errors before listing them, it will be impossible to determine what errors occurred and difficult to identify the problem that caused them.

---

If communication errors occur, ensure that the battery backup is enabled and then cycle power to the controller. If communication errors continue, record No Communication as the fatal error, and go to step 4.

2. Execute AUX Function 11 — CPU partial restart. If this fails to clear the error, execute AUX Function 12 — CPU complete restart.
3. If the fatal error persists, ensure that the battery backup is enabled, power cycle the CPU, then reattempt step 2 and execute the AUX Function 10 — CPU power-up restart.
4. If you have been unable to clear the fatal error to this point, you must re-initialize the CPU. Disable the battery backup (turn off switch 9 of the dipswitch) and cycle power to the CPU (or execute AUX Function 10). This clears the CPU memory.
5. If the CPU GOOD LED comes on, restore the battery backup by turning on switch 9 of the dipswitch. You must now use your programming unit to restore your program.
6. If the CPU GOOD LED does not turn on at this time, your CPU may have a hardware failure.

### Calling for Assistance

Before calling for assistance, be sure that you have the following information available.

- List of fatal and non-fatal errors
- Model number
- CPU serial number
- CPU software revision (execute AUX Function 15 or check the EPROM label)
- Sequence of events leading up to the failure

## 7.4 Troubleshooting Controller Non-Fatal Errors

---

Definitions of non-fatal errors are listed in this section along with suggested courses of action.

- Scan overrun — The CPU scan time is not sufficient to execute the user program.
- I/O base failure — A configured base is not connected or has failed. Check the I/O cabling and/or I/O configuration.
- Special function port failure — A communication port on an SF module has failed. Check all SF modules.
- I/O module failure — A configured module is not present or is reporting an error. Run AUX 25 or see Appendix C to identify the module.
- I/O table does not agree with modules installed — The configured I/O does not match what is installed in the base. Check the I/O configuration and/or run AUX 25.

---

**NOTE:** Series 505 I/O modules with date codes before January 1988 cannot be used with a TI545/TI555 CPU. See Appendix C for details.

---

## 7.5 Troubleshooting by Using Status Words

---

In addition to auxiliary functions, the CPU provides operational information in the form of 16-bit status words. Status words can be read with your programming device. Status words can also be used within a RLL program thus allowing the system to execute diagnostics during run-time conditions.

Status words supported by the CPU are described in detail in the *SIMATIC TI505 Programming Reference Manual*.

## 7.6 Troubleshooting EEPROMs or EPROMs

---

EEPROMs and EPROMs are generally not serviceable and must be replaced if they become defective. Before replacement however, review material in Chapter 5, Using an EEPROM or EPROM, and perform the following checks.

- Ensure that the EEPROM programming enable strap is installed correctly on the jumper pin E18. (See Figure 5-1.)
- Ensure that an EEPROM or EPROM is installed, depending on your use.
- Ensure that all EEPROM (EPROM) pins are properly seated in the socket.

Other possible causes for errors include the following.

- The EEPROM may already have been programmed (and not erased). Use the AUX Function 84 to erase program data on the EEPROM.
- The size of your user program (L, K, S, and U memories) that is being stored may exceed the size of the (E)EPROM (126 or 254K bytes).

---

**NOTE:** To help ensure that the user program will be saved, the total user memory space occupied by the user program must not exceed the size of the (E)EPROM minus 2K bytes (126K or 254K bytes). If the total user memory (not system memory) space occupied by these user programs is greater than this value, none of the data is saved and the error message, **OPERATION FAILED**, is displayed on the screen when attempting to save the data.

---



## 7.7 Troubleshooting the Power Supply

---

Complete the following steps when troubleshooting the power supply.

1. Ensure that the power budget has not been exceeded and that the module is properly installed.
2. After making sure the backup battery is on (so the program will not be lost), disable all power to the system for at least 90 seconds.
3. Restore system power.
4. If the problem still exists, turn off power to the system.

---

 **WARNING**

**To minimize risk of shock hazard, always turn off the controller before removing or installing a CPU or I/O module.**

**Failure to do so could cause death or serious injury and/or damage to equipment.**

**Ensure that controller power is turned off before removing or installing a CPU or I/O module.**

---

5. Remove the power supply module from the base. This step is not required for the PPX:505–6663 power supply.
  - a. Ensure that the jumper in the back of the power supply module is set to the correct line voltage.
  - b. If the voltage has been set incorrectly, wait at least one minute before touching the jumper. Then move the jumper to the appropriate quick-connect pin.
6. Ensure that the wires attached to the terminal screws on the bezel are secure and that the user-supplied power source is functional.
7. Verify that the fuse (located on the bezel) has not opened. Follow steps 8. through 12. to replace the fuse, if necessary, with the appropriate fuse. See Figure 7-2 .

---

 **WARNING**

**Before you replace a fuse, disable all power to the base .**

**Failure to do so could cause death or serious injury and/or damage to equipment.**

**Disable all power to the base before replacing a fuse.**

---

- 
8. Turn off power to the power supply module.
  9. Turn the fuse cap counterclockwise a half-turn with a standard screwdriver.
  10. Pull the fuse cap out of the fuse socket.
  11. Remove and replace fuse.

---

**NOTE:** PPX:505-6660A requires a 3 A, 250 V, slow-blow fuse. PPX:505-6663 requires an 8 A, 250 V, normal-blow fuse.

---

12. Place the fuse in socket and turn it clockwise with a standard screwdriver.

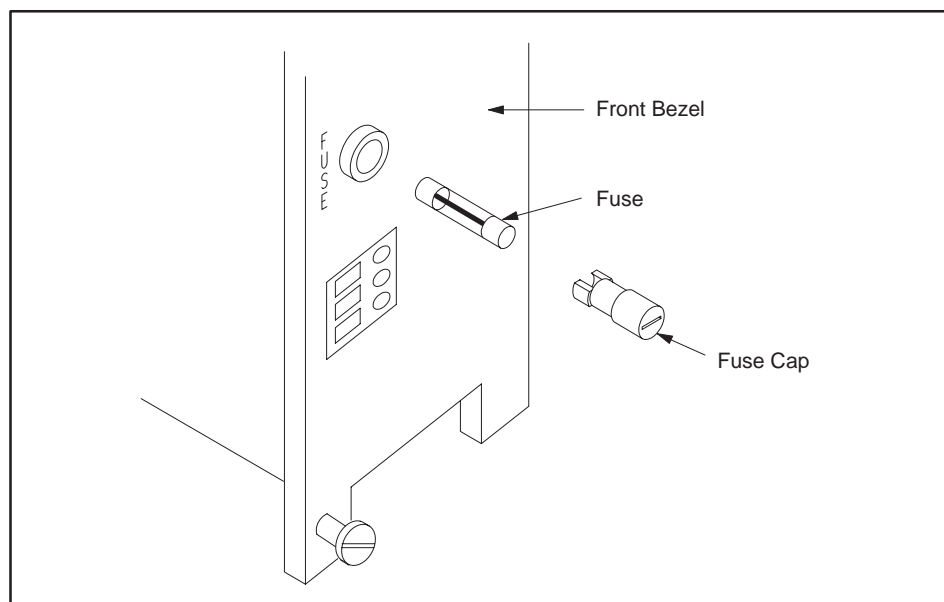

**Figure 7-2 Replacing PPX:505-6660 Power Supply Fuse**

13. Re-install the power supply and apply power to the system.
14. If the power supply continues to malfunction, replace it.

Follow procedures established at your site for processing defective equipment. If necessary, contact your distributor or sales office in the United States or call Siemens Industrial Automation, Inc., at (800) 964-4114 for assistance in contacting your distributor or sales office.

## 7.8 Checking RS-485 (Twisted Pair) Cable Installation

---

### Using Digital or Analog Meter

To locate problems with RS-485 communication links, use a digital or analog meter capable of measuring resistance between 0 and 150 ohms.

Measure the line-to-line and line-to-shield resistance as follows:

1. Remove power from the controller and all bases.
2. Disconnect the CPU and all RBCs from the cable by removing the 9-pin D-connector.
3. Measure the resistance from either isolated wire to the other isolated wire (line-to-line) and record this value.
4. Measure the resistance from one line to the shield wire and record this value.
5. Measure the resistance from the other line to the shield wire and record this value.
6. Compare the values you recorded with those in Table 7-3.

Table 7-3 Cable Resistance

Trunk Cable Type	9860 or 9271		9182	
	Min	Max	Min	Max
Line-to-line	52 ohms	70 ohms	63 ohms	87 ohms
Line-to-shield	100K ohms	–	100K ohms	–

## Checking RS-485 (Twisted Pair) Cable Installation (continued)

---

### Resistance Below Minimum

Line-to-line resistance that is below the minimum specified in Table 7-3 may be caused by the following:

- Incorrect termination resistors are installed.
- More than two termination resistors are installed.
- There is a short in the cable.

Line-to-shield resistance that is below the minimum specified in Table 7-3 may be caused by the following:

- One of the 9-pin connectors is connected to an RBC or CPU.
- Cable line wires are shorted to the shield.

### Resistance Above Maximum

Line-to-line resistance that is above the maximum specified in Table 7-3 may be caused by the following:

- Incorrect termination resistors are installed.
- Fewer than two termination resistors are installed.
- The cable is open between the point of measurement and one or both of the termination resistors.

## 7.9 Recommended Spare Parts List

---

Siemens Industrial Automation, Inc., recommends that you maintain a 10% surplus of your system's I/O modules as available spare parts. Depending upon the number of CPUs that you have installed, you may wish to stock an extra controller as well. Additional spare parts, depending upon your site configuration, include the following:

- PPX:505-6504, 4 I/O slots base.
- PPX:505-6508, 8 I/O slots base.
- PPX:505-6511, 11 I/O slots base.
- PPX:505-6516, 16 I/O slots base (19-inch rack compatible).
- PPX:505-6660A or PPX:505-6663, Power Supply Module.
- 3.0A/250 V, slow-blow fuse (3AG) for PPX:505-6660A, PPX:2587679-8015, Qty 5.
- 8.0A/250 V, normal-blow fuse (3AG) for PPX:505-6663, PPX:2587679-8018, Qty 5.

Order the following spare parts as needed from your supplier or Siemens Industrial Automation:

- EEPROM, 128K x 8, PPX:2587681-8022  
EEPROM, 256K x 8, PPX:2587681-8030.
- EPROM, 128K x 8, PPX:2587681-8023  
EPROM, 256K x 8, PPX:2587681-8031.
- RS-232-C/RS-423 9-to-9 Pin Programming Cable, Part #2601094-8001.

*Appendix A*  
System Specifications

---

A.1 Series 505 System Specifications ..... A-2

## A.1 Series 505 System Specifications

---

Table A-1 Environmental Specifications

Models	PPX:545–1102 Controller PPX:555–1101 Controller PPX:555–1102 Controller PPX:505–6851 Remote Base Controller PPX:505–6660A Power Supply PPX:505–6663 Power Supply
Storage Temperature	–40° to 70°C; –40° to 158°F
Operating Temperature	0° to 60°C; 32° to 140°F
Relative Humidity	5% to 95% noncondensing
Vibration	
Sinusoidal:	IEC 68-2-6, Test Fc; 0.15 mm peak-to-peak, 10–57 Hz; 1.0 g, 57–150 Hz
Random:	NAVMAT P-9492 or IEC 68-2-34, Test Fdc with 0.04 g <sup>2</sup> /Hz, 80–350 Hz, and 3 dB/octave rolloff, 80–20 Hz and 350–2000 Hz at 10 min/axis
Impact Shock	IEC, 68-2-27, Test Ea; Half sine, 15 g 11 ms
Pollution Degree	2, IEC664, 684A
Electric Noise Immunity	
Conducted noise:	IEC 801, Part 4, Level 3 MIL-STD-461B, Part 4; CS01, CS02, CS06 IEC 255-4, Appendix C EEC 4517/79 Com(78) 766 Final, Part 4 IEEE 472, 2.5 kV
Radiated noise:	IEC 801 Part 3, Level 3 MIL-STD-461B, Part 4; RS01, RS02
Electrostatic discharge:	IEC 801, Part 2, Level 4 (15 kV)
System Isolation	1500 Vrms (user-side to controller-side)

Table A-2 General Series 505 Specifications

Input Power	Provided by power supply module PPX:505-6660A for user-supplied 110/220 VAC PPX:505-6663 for user-supplied 24 VDC
Maximum power drawn from base by TI545/TI555 controller	4 W @ +5 VDC, 0.2 W @ -5 VDC
Maximum power drawn from base by RBC:	5 W @ +5 VDC 0.2 W @ -5 VDC
Battery Backup	3.0 V rechargeable lithium battery 3 years typical storage (0° to 60°C) 6 months typical continuous life (0° to 60°C)
Communication Ports	RS-232-C/RS-423 RS-232/422
I/O Port	Remote: RS-485 Local: back-plane connectors
User Memory Capacity	RAM for 545-1102: 192K bytes (user-configurable) RAM for 555-1101: 384K bytes (user-configurable) RAM for 555-1102: 1920K bytes (user-configurable) TI545/TI555 EEPROM(EEPROM): 126K bytes (total), or TI555 EEPROM(EEPROM): 254K bytes (total)
Memory Backup	EEPROM, 128K bytes (Part #2587681-8022) EEPROM, 256K bytes (Part #2587681-8030) EPROM, 128K bytes (Part #25587681-8023) EPROM, 256K bytes (Part #2587681-8031) Battery backed-up static RAM
Corrosion Protection	All parts are of corrosion-resistant material or are plated or painted as corrosion protection.
Agency Approvals (All controller models and power supply)	UL Listed (industrial control equipment) CSA Certified (process control equipment) FM approved (Class I, Div. 2, Haz. Loc.)



## Series 505 System Specifications (continued)

Table A-3 Power Supply Electrical Specifications

Input Voltage Select, PPX:505-6660	110/220 VAC (User-selectable)
Voltage Range PPX:505-6660A	85-132 VAC (110), or 170-264 VAC (220)
PPX:505-6663	20-30 VDC (24)
Frequency PPX:505-6660A	47-63 Hz
Input Current Peak Inrush - PPX:505-6660A Peak Inrush - PPX:505-6663	50 A maximum 20 A maximum
Steady state - PPX:505-6660A Steady state - PPX:505-6663	2 A rms maximum 8 A zero to peak 5 A DC maximum
Volt-Amp rating - PPX:505-6660A Wattage rating - PPX:505-6663	200 V-A 100 W maximum
Output	55 W at +5 VDC 3.75 W at -5 VDC
Fuse PPX:505-6660A PPX:505-6663	3.0A/250 V, slow-blow, 3 AG 8.0A/250 V, normal-blow, 3 AG

In addition, the system complies with applicable requirements of Verband Deutscher Elektrotechniker (VDE) 0160: Electrical Equipment, except 220 VAC Input Modules (No. PPX:505-44XX).

Series 505 products have been developed with consideration of the draft standard for programmable controllers as described in the proposed standard of the International Electrotechnical Commission Committee (IEC-65A/WG6, Part 2).

Information concerning product reliability and compliance to the IEC or other standards can be provided upon request. Contact Siemens Industrial Automation at the following address.

Siemens Industrial Automation Incorporated  
3000 Bill Garland Road  
P.O. Box 1255,  
Johnson City, TN. 37605-1255

*Appendix B*

# Module Power Consumption

---

B.1	Series 505 Modules .....	B-2
-----	--------------------------	-----

## B.1 Series 505 Modules

Table B-1 Series 505 Module Power Requirements

Model Number	Description	Special Function Module	Immediate I/O	Maximum DC Power Consumption (Watts)	
				+5 V	-5 V
PPX:505-4008 <sup>1</sup>	24 VAC Input (8 point)	–	✓	2.0	–
PPX:505-4016 <sup>1</sup>	24 VAC Input (16 point)	–	✓	2.0	–
PPX:505-4032 <sup>1</sup>	24 VAC Input (32 point)	–	✓	2.0	–
PPX:505-4108 <sup>1</sup>	LVDC/TTL (8 point)	–	✓	2.0	–
PPX:505-4116 <sup>1</sup>	LVDC/TTL (16 point)	–	✓	2.0	–
PPX:505-4132 <sup>1</sup>	LVDC/TTL (32 point)	–	✓	2.0	–
PPX:505-4208 <sup>1</sup>	110 VAC Input (8 point)	–	✓	2.0	–
PPX:505-4216 <sup>1</sup>	110 VAC Input (16 point)	–	✓	2.0	–
PPX:505-4232 <sup>1</sup>	110 VAC Input (32 point)	–	✓	2.0	–
PPX:505-4308 <sup>1</sup>	24 VDC Input (8 point)	–	✓	2.0	–
PPX:505-4316 <sup>1</sup>	24 VDC Input (16 point)	–	✓	2.0	–
PPX:505-4317	24 VDC Interrupt Input (16/32)	–	✓ <sup>2</sup>	2.0	–
PPX:505-4318	48 VDC Interrupt Input (16/32)	–	✓	2.0	–
PPX:505-4319	125 VDC Interrupt Input (16/32)	–	✓	2.0	–
PPX:505-4332 <sup>1</sup>	24 VDC Input (32 point)	–	✓	2.0	–
PPX:505-4408 <sup>1</sup>	220 VAC Input (8 point)	–	✓	2.0	–
PPX:505-4416 <sup>1</sup>	220 VAC Input (16 point)	–	✓	2.0	–
PPX:505-4432 <sup>1</sup>	220 VAC Input (32 point)	–	✓	2.0	–
PPX:505-4508 <sup>1</sup>	24 VDC Output (8 point)	–	✓	2.5	–
PPX:505-4516 <sup>1</sup>	24 VDC Output (16 point)	–	✓	2.5	–
PPX:505-4532 <sup>1</sup>	24 VDC Output (32 point)	–	✓	2.5	–
PPX:505-4608 <sup>1</sup>	110 VAC Output (8 point)	–	✓	2.5	–
PPX:505-4616 <sup>1</sup>	110 VAC Output (16 point)	–	✓	2.5	–
PPX:505-4632 <sup>1</sup>	110 VAC Output (32 point)	–	✓	2.5	–
PPX:505-4708 <sup>1</sup>	24 VDC Output (8 point)	–	✓	5.0	–
PPX:505-4716 <sup>1</sup>	24 VDC Output (16 point)	–	✓	5.0	–
PPX:505-4732 <sup>1</sup>	24 VDC Output (32 point)	–	✓	5.0	–

<sup>1</sup> Modules that are affected by date code restrictions. See Appendix C.  
<sup>2</sup> Interrupt mode operation requires TI545 with Firmware Release 2.1 or later, or TI555 with Firmware Release 1.1 or later.

Table B-1 Series 505 Module Power Requirements (continued)

Model Number	Description	Special Function Module	Immediate I/O	Maximum DC Power Consumption (Watts)	
PPX:505-4808 <sup>1</sup>	220 VAC Output (8 point)	–	✓	5.0	–
PPX:505-4816 <sup>1</sup>	220 VAC Output (16 point)	–	✓	5.0	–
PPX:505-4832 <sup>1</sup>	220 VAC Output (32 point)	–	✓	5.0	–
PPX:505-4908 <sup>1</sup>	Relay Output Form C (8 point)	–	✓	2.5	–
PPX:505-4916 <sup>1</sup>	Relay Output Form A (16 point)	–	✓	2.5	–
PPX:505-4932 <sup>1</sup>	Relay Output Form A (32 point)	–	✓	2.5	–
PPX:505-5100	TurboPlastic	✓		7.0	0
PPX:505-5103	TurboParison	✓		7.0	0
PPX:505-5184	MODNIM (Modbus NIM)	✓		8.0	–
PPX:505-5190	6MTCC: TI505-to-6MT Interface		✓	4.0	–
PPX:505-5417 <sup>1</sup>	Relay Output, 115 VDC (16 point)		✓	3.0	–
PPX:505-6010 <sup>1</sup>	Input Simulator		✓	2.0	–
PPX:505-6011 <sup>1</sup>	Output Simulator		✓	2.5	–
PPX:505-6108	Analog Input		✓ <sup>3</sup>	4.0	–
PPX:505-6108A	Analog Input		✓ <sup>3</sup>	4.0	–
PPX:505-6202	Analog Output (2 point)		✓ <sup>3</sup>	2.5	–
PPX:505-6204	Analog Output (4 point)		✓ <sup>3</sup>	5.0	–
PPX:505-6208	Analog Output (8 point)		✓ <sup>3</sup>	5.0	–
PPX:505-6208A	Analog Output (8 point)		✓ <sup>3</sup>	2.0	–
PPX:505-6308	Word Input		✓ <sup>3</sup>	4.0	–
PPX:505-6408	Word Output		✓ <sup>3</sup>	5.0	–

<sup>1</sup> Modules that are affected by date code restrictions. See Appendix C.  
<sup>2</sup> Interrupt mode operation requires TI545 with Firmware Release 2.1 or later, or TI555 with Firmware Release 1.1 or later.  
<sup>3</sup> Supported by TI555 Release 3.0 or TI545-1102 Release 3.0.

## Series 505 Modules (continued)

Table B-1 Series 505 Module Power Requirements (continued)

Model Number	Description	Special Function Module	Immediate I/O	Maximum DC Power Consumption (Watts)	
				+5 V	-5 V
PPX:505-6851A	Remote Base Controller (RBC)			5.0	0.200
PPX:505-6860	RF to RS-485 Converter			4	4
PPX:505-7002	High Speed Counter & Encoder		✓ <sup>3</sup>	2.0	–
PPX:505-7003	High Speed Counter Encoder		✓ <sup>3</sup>	2.0	–
PPX:505-7012	8 In/4 Out Analog		✓ <sup>2</sup>	3.0	0.030
PPX:505-7016	Bipolar 8 In/4 Out Analog		✓	3.0	0.030
PPX:505-7028	Thermocouple Input		✓	2.2	0.01
PPX:505-7038	RTD Input		✓	2.2	0
PPX:505-7101	BASIC Module	✓		6.0	0.125
PPX:505-7190	7MT Channel Controller			4.0	–
PPX:505-7201	FIM (Field Interface Module)			2.5	–
PPX:505-7339	NIM (Network Interface Module)	✓		8.0	–
PPX:505-7340	Dual Media NIM	✓		8.0	–
PPX:505-7354	Peerlink	✓		8.0	–
PPX:505-ATM -0220 -0440, -4120	386/ATM Coprocessor Module (IBM AT-Compatible Coprocessor)	✓		11.0	0.2
PPX:545-1102 PPX:555-1101 PPX:555-1102	Programmable Logic Controller			4.0	0.200

**Notes:**  
<sup>1</sup> Modules that are affected by date code restrictions. See Appendix C.  
<sup>2</sup> Only inputs should be used for immediate I/O when using Release 1.1.x of TI555. No restriction with Release 3.0.  
<sup>3</sup> Supported by TI555 Release 3.0 or TI545-1102 Release 3.0.  
<sup>4</sup> Refer to TI555 Release 3.0 Notes.  
 For any module not listed here, see the manual for that module.

# TI545/TI555 CPU and I/O Compatibility

---

<b>C.1</b>	<b>I/O Module Compatibility</b> .....	<b>C-2</b>
	I/O Modules not Compatible with TI545/TI555 CPUs .....	C-2
	Determining the Compatibility of a Module .....	C-3
	Series 505 High Speed Counter .....	C-3
<b>C.2</b>	<b>Reading the Serial Numbers</b> .....	<b>C-4</b>
	Determining the Manufacturing Date .....	C-4
	Examples .....	C-4
	86ML8712020175_ .....	C-4
	86ML8712020175G .....	C-4
	86ML8801041324_ .....	C-4

## C.1 I/O Module Compatibility

---

### I/O Modules not Compatible with TI545/TI555 CPUs

Unmodified Series 505 discrete I/O modules manufactured prior to January, 1988 are unable to report module status and, therefore, cannot be recognized by the TI545/TI555 CPU (that is, inputs are not read and outputs are not written). Series 505 discrete I/O modules manufactured in January, 1988 or later and those manufactured prior to this date that have been modified contain the status reporting mechanism and are compatible with the TI545/TI555 CPU.

The Series 505 Simulators (PPX:505–6010, 32-Input Simulator and PPX:505–6011, 32-Output Simulator) are also affected by this compatibility restriction.

---

**NOTE:** Note<sup>1</sup> in Table B-1 identifies all affected modules.

---

The following modules are fully compatible with the TI545/TI555 CPU, regardless of the manufacturing date.

- All Series 500 I/O and all non-discrete Series 505 I/O, such as analog modules (except for the High Speed Counter, as described on page C-3)
- Series 505 Word modules (PPX:505–6308, 8-Channel Word Input and PPX:505–6408, 8-Channel Word Output)

---

Determining the Compatibility of a Module

The serial number found on each module contains the manufacturing date of the module. The fifth through the eighth characters of the serial number determines the manufacturing date; see Figure C-1.

---

NOTE: Units manufactured prior to January, 1988 that have been modified have the letter G immediately following the serial number.

---

Before you install Series 505 discrete modules into a TI545/TI555 system, check the serial number of each module to ensure it is compatible with the TI545/TI555 CPU.

Series 505 High Speed Counter

High Speed Counter modules (PPX:505-7002) manufactured prior to May 1990 will not operate properly in a TI545/TI555 controller's local base configuration. If a High Speed Counter is placed in a TI545/TI555 controller's local base configuration, the WX inputs will intermittently set to FFs, which could cause improper operation.

---

NOTE: High Speed Counter modules manufactured prior to May 1990 that have been modified for TI545/TI555 controller's local base compatibility have the letter A immediately following the serial number.

---

Before you install Series 505 High Speed Counter modules into a TI545/TI555 local base, check the serial number of *each* module to ensure that it is compatible with the TI545/TI555 local base.

 **WARNING**

---

**Do not use an unmodified Series 505 High Speed Counter module manufactured prior to May 1990 in a TI545/TI555 controller's local base.**

**In a Series 505 High Speed Counter, WX inputs may change to FFs that could change the High Speed Counter outputs to an unsafe condition. This could result in death or serious injury and/or damage to equipment.**

**Refer to the Safety Considerations Guidelines, part no. 2588015-0003 (shipped with each TI545/TI555 controller), for details. Follow Siemens Industrial Automation, Inc.'s recommended safety installation guidelines.**

---



## C.2 Reading the Serial Numbers

### Determining the Manufacturing Date

The fifth through the eighth characters of the serial number determines the manufacturing date. Figure C-1 shows how to read the serial numbers.

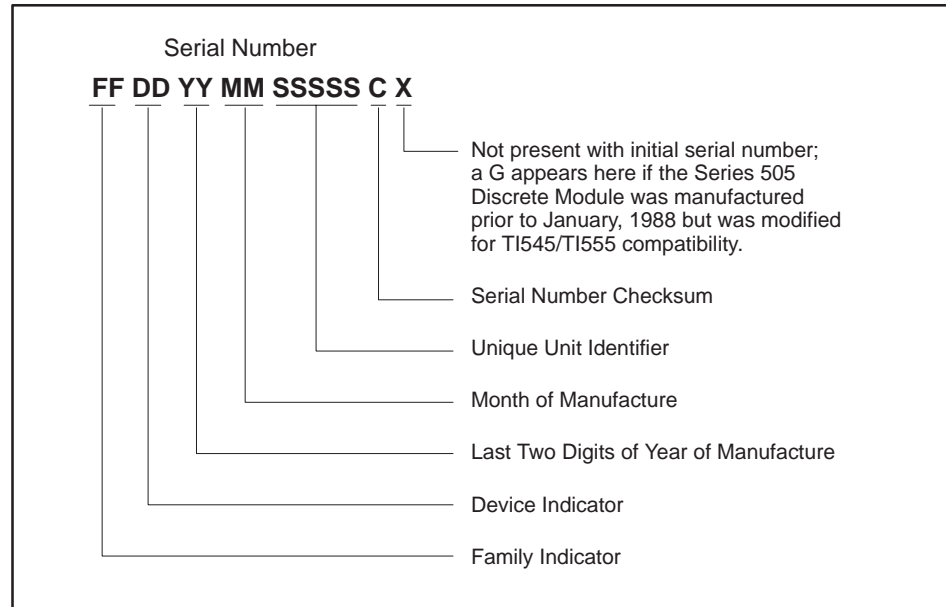

Figure C-1 Serial Number Definition

### Examples

The following examples demonstrate how to read the serial number on the modules.

86ML8712020175\_

This module was manufactured in December (12) of 1987 (87). This unit is not compatible with the TI545/TI555 controller because it was manufactured prior to January, 1988 and the letter G (designating that a modification occurred) does not appear at the end of the serial number.

86ML8712020175G

This module was manufactured in December (12) of 1987 (87). This unit is compatible with the TI545/TI555 controller because it was manufactured prior to January, 1988 and the letter G (designating that a modification occurred) appears at the end of the serial number.

86ML8801041324\_

This module was manufactured in January (01) of 1988 (88). This unit is compatible with the TI545/TI555 controller because it was manufactured in January, 1988. (The letter G is not required if the module was manufactured in January, 1988 or later.)

# Upgrading Series 500 Installations

---

<b>D.1</b>	<b>Series 500 System Installations</b> .....	<b>D-2</b>
<b>D.2</b>	<b>Upgrading a TI520/TI520C/TI530/TI530C/TI530T System</b> .....	<b>D-3</b>
	Install RS-485 Twin Axial Cabling .....	D-3
	Check Base to be Upgraded .....	D-4
	Upgrading 14-Slot, 12-Slot, 6-Slot Bases .....	D-4
	Upgrading 16-Slot and 8-Slot Bases .....	D-4
	Finish Upgrade with these Steps .....	D-4
<b>D.3</b>	<b>Upgrading an RS-485 Based TI560/TI565/TI560T/TI565P System</b> .....	<b>D-6</b>
<b>D.4</b>	<b>Upgrading an RF Based TI560/TI565/TI560T/TI565P System</b> .....	<b>D-8</b>
<b>D.5</b>	<b>Installing a PPX:500-5114A RBC</b> .....	<b>D-10</b>
	Output State Selection .....	D-10
	Installing a Series 500 RBC .....	D-11
	Setting Baud Rates .....	D-12
	Assigning Base Numbers .....	D-12
	Series 500 RBC LED Display .....	D-13

## D.1 Series 500 System Installations

---

You can upgrade an existing Series 500 system, by replacing the controller with a TI545–1102 or a TI555. The following Series 500 systems can be upgraded:

- SIMATIC® TI520™, TI520C™, TI530™, TI530C™, and TI530T™ systems.
- SIMATIC TI560™, TI560T™, TI565™, and TI565P™ systems using twin axial (RS-485) remote I/O channels.
- SIMATIC TI560, TI560T, TI565, and TI565P systems using coaxial (RF) remote I/O channels.

Refer to Section D.2 for information about upgrading an existing TI520, TI520C, TI530, TI530C, or TI530T systems.

Refer to Section D.3 for information about upgrading an existing TI560, TI560T, TI565, or TI565P system with one or more RS-485 remote I/O channels.

Refer to Section D.4 for information about upgrading an existing TI560, TI560T, TI565, or TI565P system with one or more coaxial remote I/O channels.

## D.2 Upgrading a TI520/TI520C/TI530/TI530C/TI530T System

---

To upgrade a TI520, TI520C, TI530, TI530C, or TI530T system to the TI545/TI555 you must install a twin axial (RS-485) remote I/O channel to connect the Series 500 bases to the TI545/TI555.

You must also convert each of the existing series 500 bases to a series 500 remote base by replacing the existing programmable controller (and I/O channel controller, if present) or the existing distributed base controller with a PPX:500–5114A (RS-485) Remote Base Controller (RBC). If the base contains a TI520, TI530, or a PPX:500–2103 distributed base controller you must install an adapter base and modular power supply before you can install the RBC in the Series 500 base.

Consider these points as you do the upgrade:

- The Series 500 physical base assembly is composed of one or two logical bases. A logical base is defined as a contiguous group of eight I/O slots. For example, the 16-slot physical base assembly has two 8-slot logical bases. Each logical base has a unique base address.

By comparison, the TI545/TI555 remote base assembly addresses up to 16 contiguous slots with a single base address.

- To reduce down time for your process, plan to install the new RS-485 twin axial cables for the I/O trunkline before upgrading the hardware for each I/O base.
- Update time for a special function module is significantly faster when you install the module in the local base, versus a remote base. Because the TI545/TI555 is installed in a Series 505 local base, Series 500 SF modules cannot be located in the TI545/TI555 local base. Therefore, if SF module updates are critical to your application, consider replacing the Series 500 SF modules with Series 505 SF modules and installing them in the TI545/TI555 local base.

If all SF modules cannot be installed in the local base, consider placing low-activity SF modules, such as the ASCII, BASIC, or Dual Comm Port (DCP) modules, in a remote base. Place high-activity modules, such as the NIM or Peerlink, in the local base.

To do an upgrade, refer to Figure D-1 and follow the procedure below.

### Install RS-485 Twin Axial Cabling

Refer to Chapter 4 “Cabling and Wiring the System,” for information about installing RS-485 twin axial cabling for the I/O trunk line. To reduce the down time for your process, install the cabling before installing new hardware in each I/O base.

## Upgrading a TI520/TI520C/TI530/TI530C/TI530T System (continued)

---

Check Base to be Upgraded

Determine the number of I/O slots in the base to be upgraded. For some bases, a PPX:500–5840 adapter base must be installed. The 14-slot, 12-slot and 6-slot bases (Upgrade Path A) do not require an adapter base. For a 16-slot or 8-slot base (Upgrade Path B), you need to install an adapter base.

---

**⚠ WARNING**

**Disable all power to bases before installing or removing modules. Failure to do so could cause death or serious injury and/or damage to equipment.**

**Ensure that all power is disabled before installing or removing modules.**

---

Upgrading 14-Slot, 12-Slot, 6-Slot Bases

For 14-slot, 12-slot and 6-slot bases follow these steps (Upgrade Path A):

1. Remove the existing controlling device(s): the controller and IOCC (if an IOCC is present), or the DBC.
2. If the power supply is in slot B, move it to slot A of the I/O base. This makes slot B of the I/O base available for an I/O module. In your I/O configuration, the slot that was previously slot #1 becomes slot #2.

Upgrading 16-Slot and 8-Slot Bases

For 16-slot and 8-slot bases follow these steps (Upgrade Path B):

1. Remove the existing controlling device(s): the controller and IOCC (if an IOCC is present), or the DBC.
2. Install a PPX:500–5840 adapter base. See user manual PPX:500–8140 for information about installing the adapter base.
3. Install an AC (PPX:500–2151A) or DC (PPX:500–2153) power supply in Slot B of the adapter base. Slot A is left empty. See the appropriate user manuals for information about the power supply.

Finish Upgrade with these Steps

These steps finish the upgrade for both Upgrade Paths A and B.

1. Install an RBC (PPX:500–5114A) in the controller slot. See Section D.5 for information about installing the RBC.
2. Set the base address (1–15) using the thumbwheel on the RBC. Base number 0 is reserved for the local base and cannot be used for an RBC.
3. Connect the twin axial cable to the RS-485 port on the RBC(s) and to the I/O port of the TI545/TI555.
4. Use APT or TISOFT to set the I/O configuration for the upgrade.

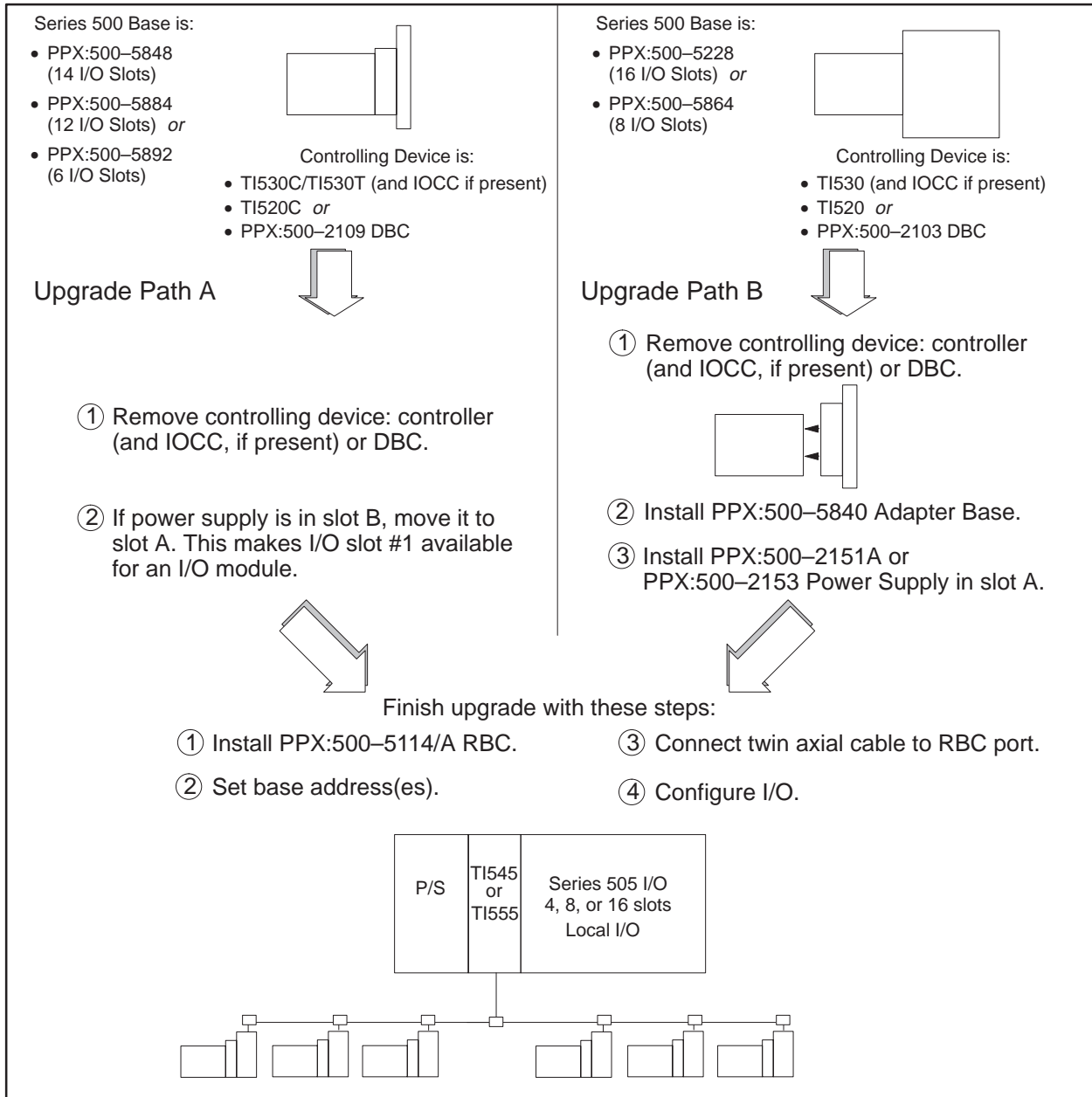

Figure D-1 Upgrading a TI520/TI520C/TI530/TI530C/TI530T System

### D.3 Upgrading an RS-485 Based TI560/TI565/TI560T/TI565P System

---

To upgrade an existing RS-485 based TI560, TI560T, TI565, TI565P system, replace the existing programmable controller, including its chassis, power supply and all installed boards with the TI505 base, power supply, and TI545/TI555 controller. The upgrade is shown graphically in Figure D-2.

---

**NOTE:** Note that the TI545/TI555 cannot directly replace an hot backup HBU configuration.

---

1. If the series 500 remote I/O installation consists of more than one twin-axial (RS-485) remote I/O channel, combine these channels into a single remote I/O channel. Refer to Section 4, "Cabling and Wiring the System," for information about installation of a twin axial remote I/O trunk line.
2. Renumber your bases so that no two bases have the same number and so that base number 0 is not used.
3. Modify the controller's I/O configuration to reflect the channel number and base number changes.
4. Connect the I/O trunk line to the TI545/TI555 I/O connector.

Update time for a special function module is significantly faster when you install the module in the local base, versus a remote base. You can improve SF module performance, and scan performance, by replacing the Series 500 SF modules with Series 505 SF modules and installing them in the TI545/TI555 local base.

If all SF modules cannot be installed in the local base, consider placing low-activity SF modules, such as the ASCII, BASIC, or DCP modules, in a remote base. Place high-activity modules, such as the NIM or Peerlink, in the local base.

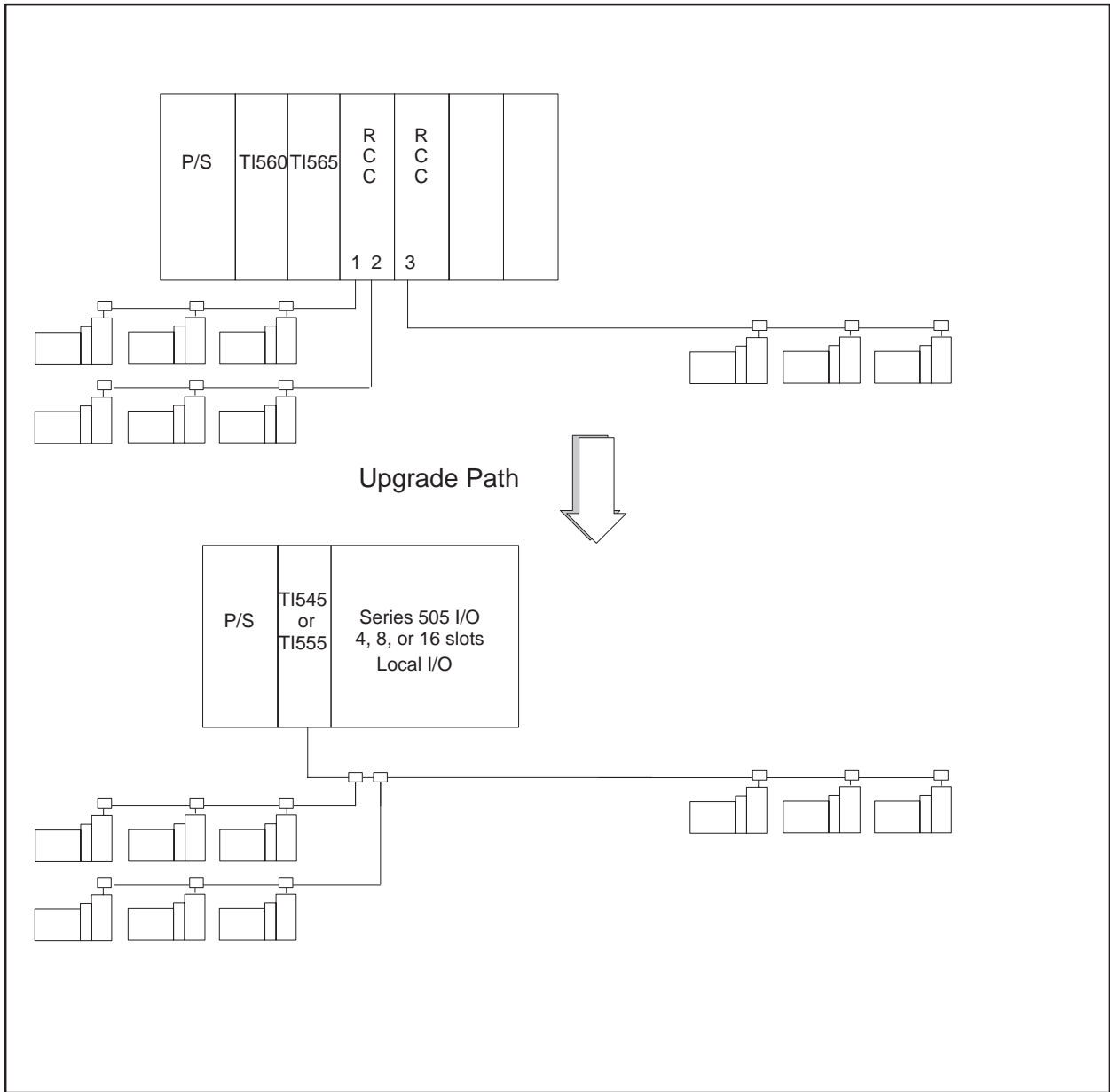

Figure D-2 Upgrading an RS-485 Based TI560/TI565/TI560T/TI565P System



## D.4 Upgrading an RF Based TI560/TI565/TI560T/TI565P System

---

To upgrade an existing RF based TI560, TI560T, TI565, TI565P system, replace the existing programmable controller, including its chassis, power supply and all installed boards with the TI505 base, power supply, TI545/TI555 controller, and RF/RS-485 converter. The upgrade is shown graphically in Figure D-3.

---

**NOTE:** Note that the TI545/TI555 cannot directly replace an hot backup HBU configuration.

---

1. If the series 500 remote I/O installation consists of more than one coaxial (RF) remote I/O channel, combine these channels into a single remote I/O channel. Refer to your existing controller's documentation for information about installation of a coaxial remote I/O channel.
2. Renumber your bases so that no two bases have the same number and so that base number 0 is not used.
3. Modify the controller's I/O configuration to reflect the channel number and base number changes.
4. Connect the resulting I/O channel to the TI545/TI555 system using the PPX:505-6860 RF to RS-485 converter.

Update time for a special function module is significantly faster when you install the module in the local base, versus a remote base. You can improve SF module performance, and scan performance, by replacing the Series 500 SF modules with Series 505 SF modules and installing them in the TI545/TI555 local base.

If all SF modules cannot be installed in the local base, consider placing low-activity SF modules, such as the ASCII, BASIC, or DCP modules, in a remote base. Place high-activity modules, such as the NIM or Peerlink, in the local base.

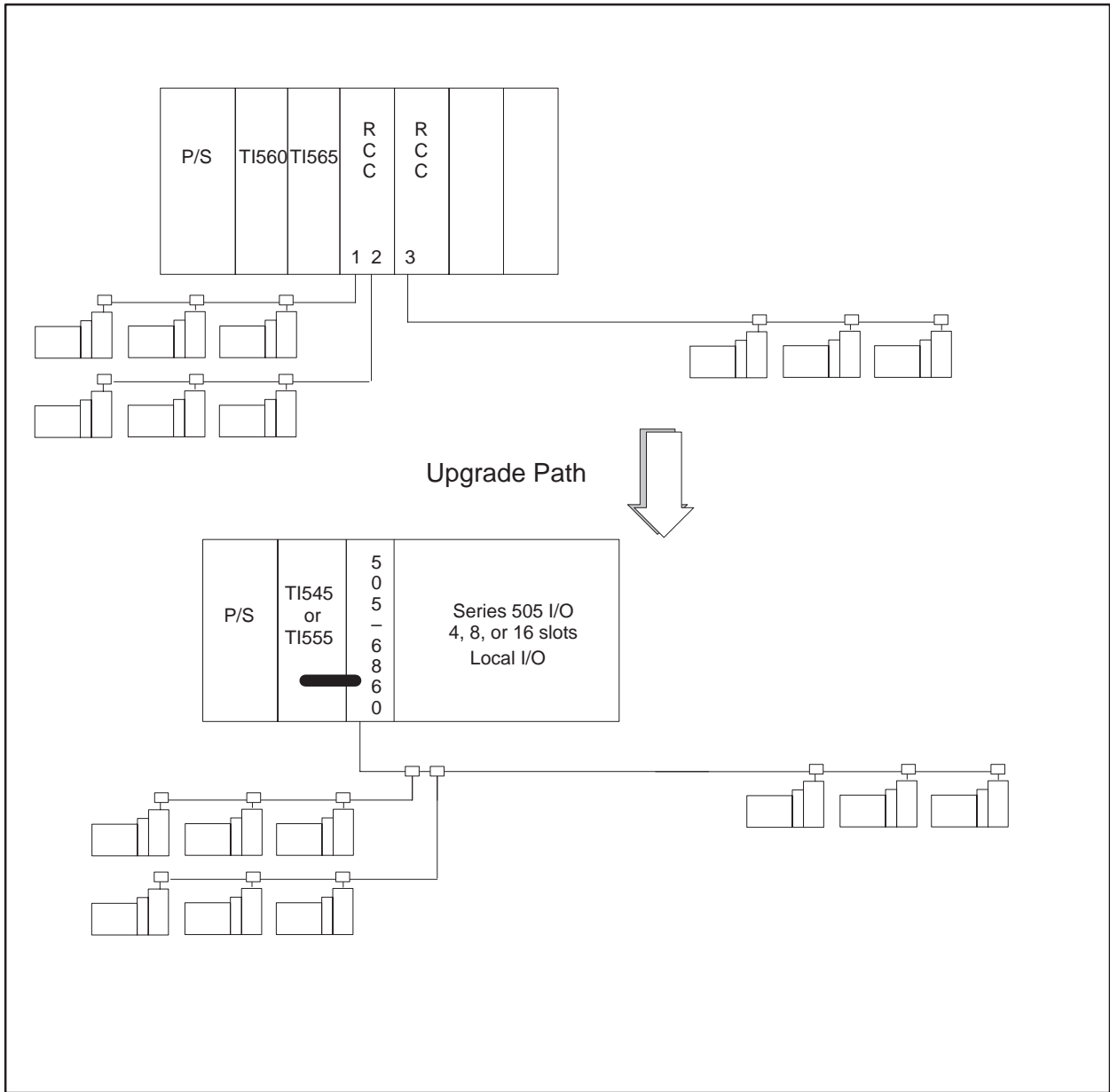

Figure D-3 Upgrading an RF Based TI560/TI565/TI560T/TI565P System

## D.5 Installing a PPX:500–5114A RBC

---

### Output State Selection

With the PPX:500–5114A RBC you can select the state of the outputs whenever a communication error occurs. Previous models of the RBC automatically set all outputs to off (0) when communication is lost. You must configure the RBC to freeze outputs in the state they were in when communication was lost, or to have them set to off (0).

The Series 500 output modules in the remote base have a selection switch for the state of the outputs during a communication loss (Figure D-4). If the output modules in the remote base have a selection switch, the freeze selection will override the output module's selection.

---

**NOTE:** If the RBC fails or the system loses power, the outputs will go off (0) regardless of the jumper selection.

---

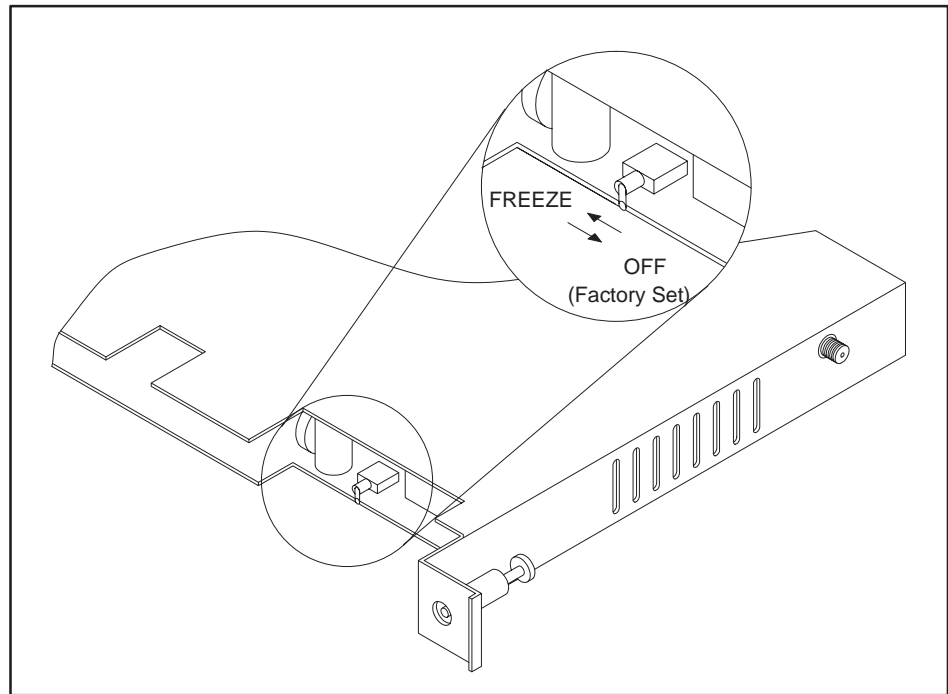

Figure D-4 Series 500 RBC Switch Selection

---

**Installing a  
Series 500 RBC**

To install the RBC, refer to Figure D-5 and follow the steps below.

1. Position the RBC so that the bezel is facing you.
2. Grasp the top and bottom of the RBC.
3. Carefully push the RBC into the slot until it mates with the back plane connectors.
4. Tighten top and bottom bezel screws.
5. Connect the RBC to the RS-485 trunkline.

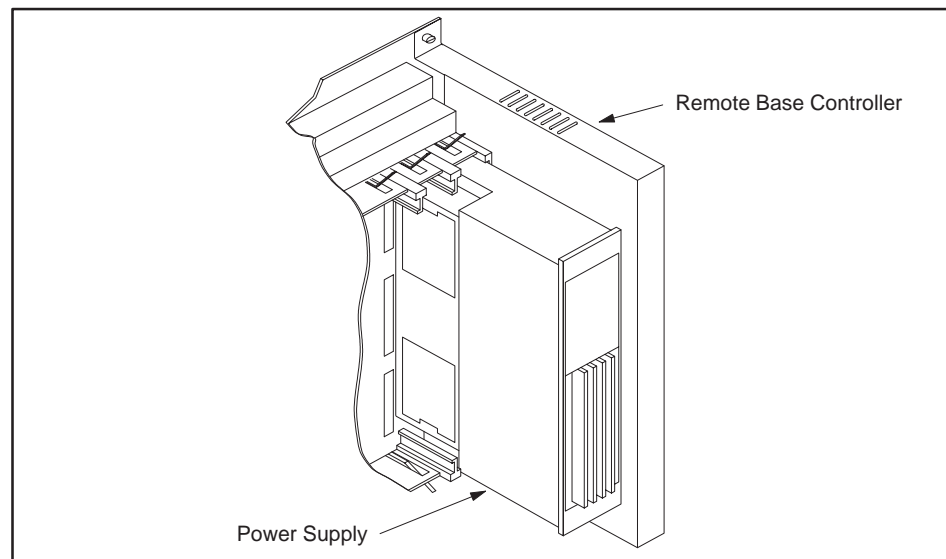

**Figure D-5 Installed Series 500 RBC**

## Installing a PPX:500–5114A RBC (continued)

### Setting Baud Rates

The RBC is equipped with a RS-232 port to program the TI545/TI555 CPU or, to troubleshoot from a remote I/O base. A baud rate thumbwheel (see Figure D-6) is used to set the baud rate for this port.

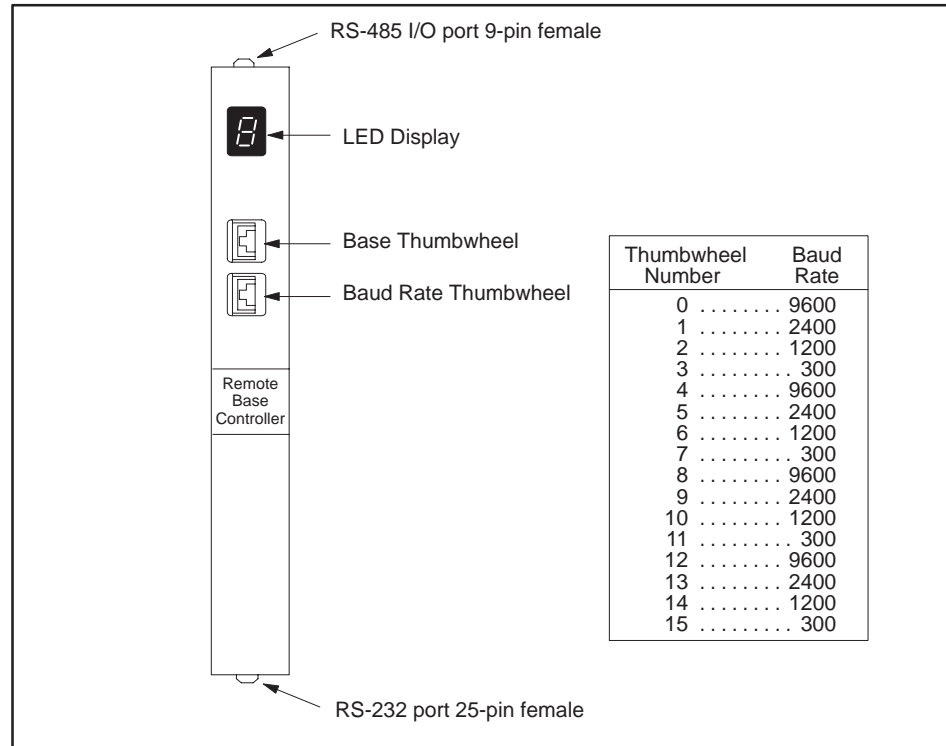

Figure D-6 Series 500 Remote Base Controller and Baud Rate Settings

### Assigning Base Numbers

The base thumbwheel (Figure D-6) is used to assign a base number to the RBC for system identification. If you are using more than one RBC, each RBC must be uniquely numbered. Refer to Table D-1 for assigning base numbers. Base number 0 is reserved for the TI545/TI555 and must not be assigned to the RBC.

Table D-1 Base Numbers

Thumbwheel Number	Base Number	Thumbwheel Number	Base Number
Do Not Use	0*	8	8
1	1	9	9
2	2	10	10
3	3	11	11
4	4	12	12
5	5	13	13
6	6	14	14
7	7	15	15

Notes: \*Base 0 is reserved on the model TI545/TI555 controller for local base assignment. Therefore, do not select number 0 on the Series 500 RBC.

Series 500 RBC  
LED Display

The display at the top of the module (refer to Table D-2) indicates the status of the Series 500 RBC. Status is displayed in integer format; see Table D-2 for definitions of the displays.

Table D-2 Series 500 RBC LED Messages

Display	Definitions
0	RBC Good
1	Self Diagnostics Failure
2	Module Mismatch
3	I/O Communication Time Out
4	RAM Parity Error
5	Not used
6	Not used
7	Communication Good, Not Configured
8	Watchdog Timer Expired

## A

Assistance, calling for, 7-8

### Auxiliary functions

- display failed I/O, 7-4
- restarting, 7-2
- run diagnostics, 7-4
- show diagnostic cell, 7-4
- used in troubleshooting, 7-2

## B

### Base

- series 500, RBC, installing and removing, D-11
- series 505
  - installing controller, 3-11–3-15
  - installing RBC, 3-19
  - panel mounting, 3-5
  - rack mounting, 3-4

### Battery, backup

- description, 1-7
- replacing, 3-13

### Baud rates

- series 500, RBC, setting thumbwheel, D-12
- series 505, 3-15
- series 505 RBC, 3-16
- setting, 3-15

## C

### Cable

- alternate cables, 4-13
- characteristics, 4-13
- connecting drop line, 4-9, 4-12, 4-14, 4-16
- connecting modems, overview, 4-18
- connecting to terminal block, 4-8, 4-10
- installing drop lines, 4-8, 4-10
- overview, 4-6
- resistance of line-to-line, 7-15
- routing guidelines, 4-4
- RS-485
  - connecting drop line, 4-8, 4-10

- connecting terminal blocks, 4-17
- measuring resistance, 7-14
- preparing trunk line, 4-16
- user-supplied equipment, 4-6

### Cable routing

- in-ceiling, 4-5
- methods, 4-4
- mounting tap, 4-5
- surface duct, 4-5
- terminal block, 4-5
- under-floor, 4-5

### Circuit breaker, guidelines for fuses/circuit breakers, 2-7

### Clock (real-time), 1-7

### Communicating with controller, devices to use, 1-5

### Communication ports, description, 1-7

## D

### Dipswitches

- back-up battery switch, 3-15
- baud rates, 3-15
- port selections, 3-14
- series 505 RBC, setting baud rate, 3-16
- setting controller, 3-13

## E

### EEPROM

- errors and corrections, 5-9
- installing, 5-6
- list of functions, 5-4
- overview, 5-2
- program
  - copying, 5-8
  - editing, 5-10
  - errors, 5-9

### Electrical noise

- avoiding, 2-8
- correcting, 2-9
- isolating from, 2-11

---

Emergency, stop switch, 2-4  
Enclosure, planning for PLC, 2-6  
EPROM  
  installing, 5-6  
  overview, 5-3  
EPROM/EEPROM  
  compatibility, 5-2  
  troubleshooting, 7-11  
  using, 5-2

Errors  
  correcting fatal errors, 7-7  
  troubleshooting fatal, 7-7

## F

Fatal errors, steps to clear, 7-8  
Features, 1-2  
Fuse  
  guidelines for fuses/circuit breakers, 2-7  
  series 505, replacing in power supply, 7-12

## G

Grounding  
  cabinet or rack, 2-14  
  connections, 2-14  
  controller, 2-14  
  earth, 2-13  
  planning for, 2-13  
  sample connection, 2-15

## H

H1 support, 1-5  
Hardware, description, 1-6  
Hot backup, D-8

## I

I/O modules  
  compatibility, determining of module, C-2

controller compatibility, C-2  
local, overview, 1-6  
mismatches, troubleshooting, 7-4  
remote, overview, 1-6  
serial number, C-4  
series 505  
  installing and removing, 3-21  
  mixing, 3-21  
  troubleshooting, 7-4

I/O port, description, 1-7

Inch switch, location, 2-5

### Installing

EEPROM and EPROM, 5-6  
planning for, 2-2  
series 500 RBC  
  in adapters, D-11  
  in bases, D-11  
series 505, 3-4  
  power supply, 3-9  
series 505 RBC, 3-19

### Installing and removing

series 500 RBC, D-11  
series 505  
  I/O modules, 3-21  
  power supply, 3-9  
  RBC, 3-19

## J

Jog switch, location, 2-5

## L

Local area networks, supported, 1-5

## M

Memory, configuration, list of types, 6-4, 6-5

### Modem

connecting, overview, 4-18  
dedicated line operation, 4-18, 4-19  
dial-up phone line, 4-19



---

## N

### Noise

- avoiding electrical, 2-8
- isolating from, 2-11
- snubbing, contact noise, 2-9

## P

### Power needs, planning for, 2-2

### Power supply

- connecting input, 4-2
- series 505, 1-7
  - installing, 3-9
  - installing and removing, 3-9
  - power consumption, 3-9
  - replacing fuse, 7-12
  - troubleshooting, 7-12

### Power-up

- memory and mode status, 5-5
- procedures, 6-2

### Printer

- connecting, 4-20
- handshaking, 4-20
- overview, 4-20

### Program

- copying into EEPROM, 5-8
- editing in EEPROM, 5-10
- software, 1-8
- storage in EEPROM, 1-8
- storage in EPROM, 1-8

## R

### RBC

- series 500
  - assigning base numbers, D-12
  - installing and removing, D-11
  - placing in bases, D-11
  - setting baud rate, D-12
- series 505
  - assigning base numbers, 3-19
  - description, 3-3
  - installing and removing, 3-19
  - installing in base, 3-19

- setting baud rate, 3-16

### RBE, support, 1-2

### Restart

- list of auxiliary functions, 7-3–7-16
- using auxiliary functions, 7-2

### RF to RS-485 converter, D-8

## S

### Safety

- guidelines, 2-3
- inch switch, 2-5
- jog switch, 2-5
- operator safety switches, 2-4

### Series 500, base numbers, assigning, D-12

### Series 500 RBC

- installing and removing, D-11
- LED messages, D-13
- placing in bases, D-11
- setting baud rates, D-12

### Series 505

- base
  - installing controller, 3-11–3-15
  - models available, 3-3
  - panel mounting, 3-5
    - models available, 3-3
  - rack mounting, 3-4
    - models available, 3-3
- connecting base, 3-3
- dipswitch, ports, 3-14
- environmental specifications, A-2
- general specifications, A-3
- I/O modules, installing and removing, 3-21
- installing, flowchart, 3-2
- module power requirements, B-2
- power supply
  - installing and removing, 3-9
  - replacing fuse, 7-12
- specifications, power supply electrical, A-4

### Series 505 RBC

- base, installing, 3-19
- base numbers, assigning, 3-19
- dipswitch (factory), 3-17
- installing and removing, 3-19
- LED messages, 3-20

---

Spare parts, list of, 7-16  
Specifications, series 505  
  general, A-3  
  power supply electrical, A-4  
  system specifications, A-2  
Start-up, procedures, 6-2  
Status words, using in troubleshooting, 7-10  
Switch, emergency stop, 2-4  
Switches  
  inch, 2-5  
  jog, 2-5  
  safety, 2-4

## T

Temperature, planning for PLC, 2-6  
Thumbwheels  
  series 500 RBC  
    assigning base numbers, D-12  
    setting baud rate, D-12  
  series 505 RBC, assigning base numbers, 3-19  
TIWAY, support, 1-5

Troubleshooting  
  cable, RS-485, 7-14  
  compare disk to PLC, 7-4  
  EPROM/EEPROM, 7-11  
  fatal errors, 7-7  
  non-fatal errors, list of, 7-9  
  reading LEDs, 7-6  
  restart, 7-2  
  series 505, power supply, 7-12  
  using auxiliary functions, 7-2  
  using status words, 7-10

## U

Upgrading  
  series 500 system, D-3-D-5  
  TI560/TI565 system, D-6-D-7, D-8-D-9

## W

Wiring  
  connecting input power, 4-2  
  planning for installation, 2-12

SIMATIC and SINEC are trademarks of Siemens AG.

Series 505, Series 500, APT, CVU100, CVU1000, CVU10000, Peerlink, TISOFT, TIWAY, PCS, 386/ATM, and 7MT are trademarks of Siemens Industrial Automation, Inc.

IBM and AT are registered trademarks of International Business Machines Incorporated.

MS-DOS is a registered trademark of Microsoft corporation.

Belden is a registered trademark of Cooper Industries, Inc.

TI505, TI520, TI520C, TI530, TI530C, TI530T, TI545, TI555, TI560, TI565, TI560T, and TI565P are trademarks of Texas Instruments Incorporated.

CSA is a registered trademark of the Canadian Standards Association.

# Customer Registration

---

We would like to know what you think about our user manuals so that we can serve you better.  
How would you rate the quality of our manuals?

	Excellent	Good	Fair	Poor
Accuracy	_____	_____	_____	_____
Organization	_____	_____	_____	_____
Clarity	_____	_____	_____	_____
Completeness	_____	_____	_____	_____
Overall design	_____	_____	_____	_____
Size	_____	_____	_____	_____
Index	_____	_____	_____	_____

Would you be interested in giving us more detailed comments about our manuals?

**Yes!** Please send me a questionnaire.

**No.** Thanks anyway.

Your Name: \_\_\_\_\_

Title: \_\_\_\_\_

Telephone Number: (\_\_\_\_) \_\_\_\_\_

Company Name: \_\_\_\_\_

Company Address: \_\_\_\_\_

\_\_\_\_\_

\_\_\_\_\_

**Manual Name:** SIMATIC TI545/555 System Manual

**Manual Assembly Number:** 2586546-0084

**Order Number:** PPX:545/555-8101-2

**Edition:** Second

**Date:** 10/94

FOLD

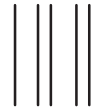

NO POSTAGE  
NECESSARY  
IF MAILED  
IN THE  
UNITED STATES

**BUSINESS REPLY MAIL**

FIRST CLASS

PERMIT NO.3

JOHNSON CITY, TN

POSTAGE WILL BE PAID BY ADDRESSEE

ATTN: Technical Communications M/S 3519  
SIEMENS INDUSTRIAL AUTOMATION INC.  
3000 BILL GARLAND RD  
P O BOX 1255  
JOHNSON CITY TN 37605-1255

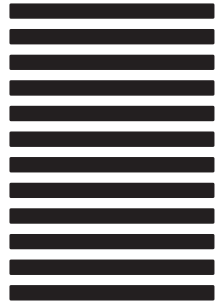

FOLD