

Sheet: CPU_80C188

2

File: CPU_80C188.sch

Sheet: ECBbus

3

File: ECBbus.sch

Sheet: BUSdrive

6

File: BUSdrive.sch

Sheet: Memory

4

File: Memory.sch

Sheet: Floppy

5

File: Floppy.sch

and PERIPHERAL
SELECT

Sheet: UART_RTC

7

File: UART_RTC.sch

Sheet: IDE_1_2

8

File: IDE_1_2.sch

and INTERRUPT
SHARING

Copyright (c) 2020 John R Coffman. All rights reserved.
Licensed for hobbyist use only.

RetroBrew Computer Group

Sheet: /
File: SBC-188v3.sch

Title: SBC-188 version 3

Size: A4

Date: 2020-01-07

Rev: 3.1-004

KiCad E.D.A. kicad 5.1.5-52549c584ubuntu16.04.1

Id: 1/8

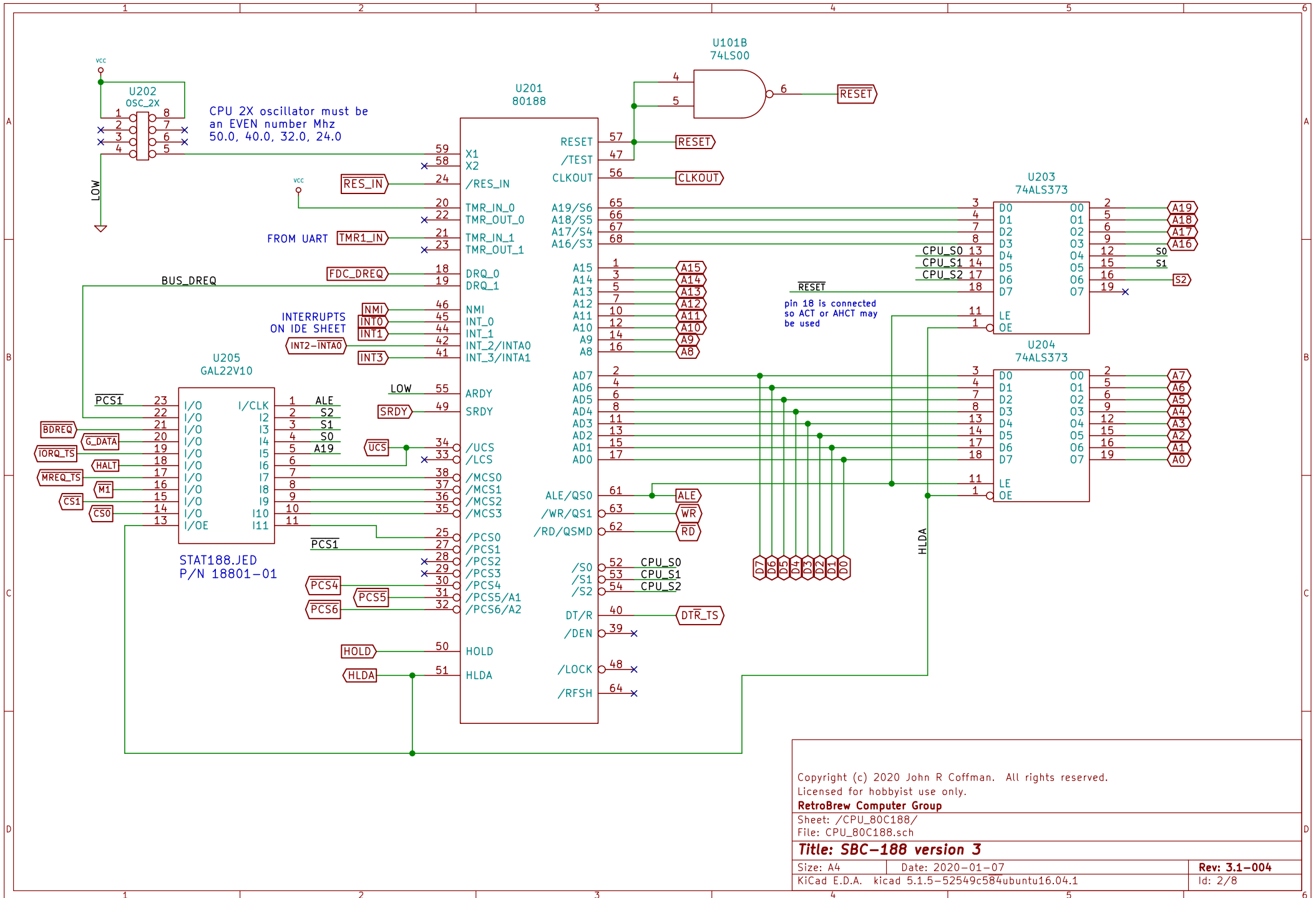

Copyright (c) 2020 John R Coffman. All rights reserved.
 Licensed for hobbyist use only.
RetroBrew Computer Group
 Sheet: /CPU_80C188/
 File: CPU_80C188.sch
Title: SBC-188 version 3
 Size: A4 Date: 2020-01-07 Rev: 3.1-004
 KiCad E.D.A. kicad 5.1.5-52549c584ubuntu16.04.1 Id: 2/8

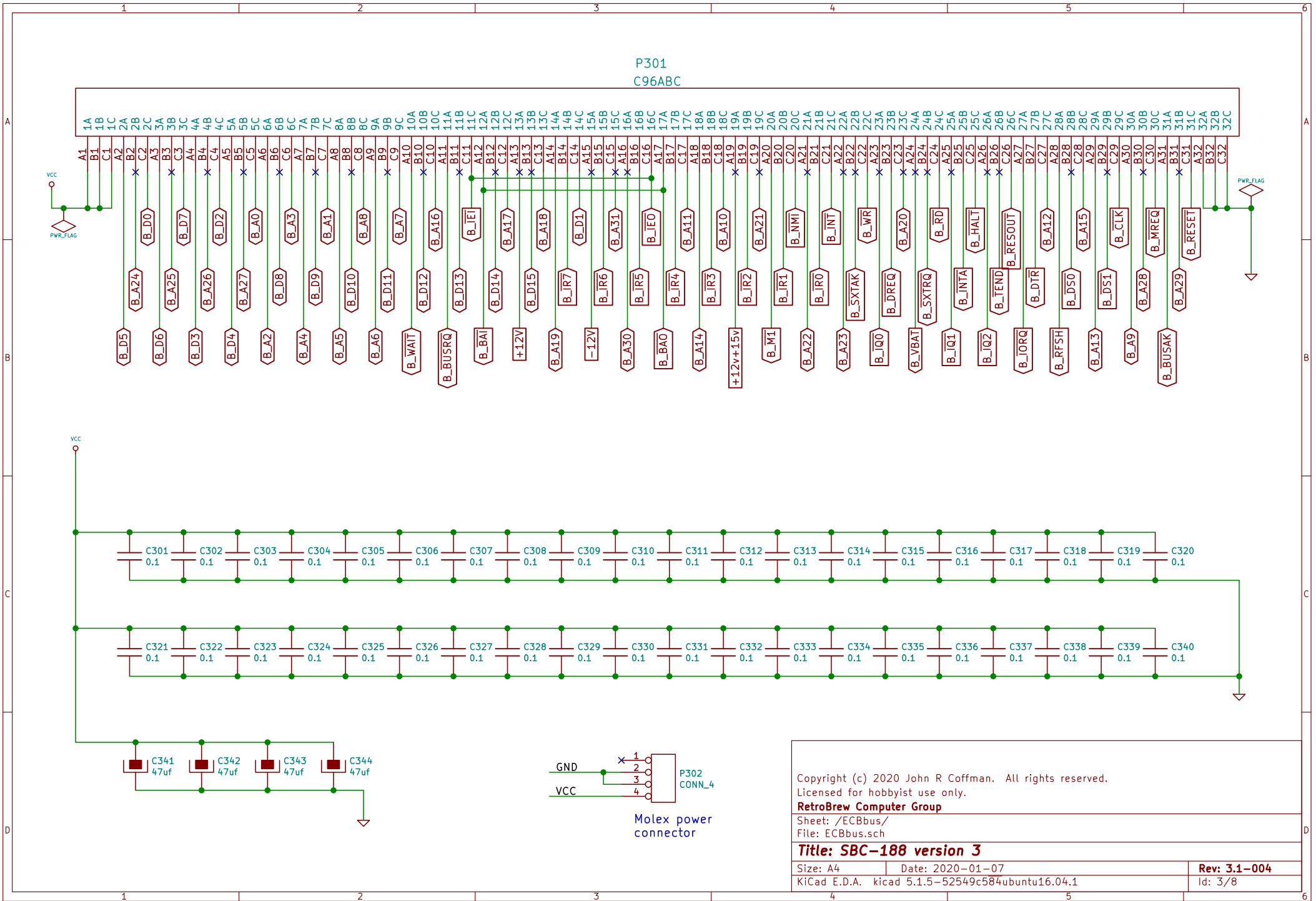

Copyright (c) 2020 John R Coffman. All rights reserved.
 Licensed for hobbyist use only.
RetroBrew Computer Group
 Sheet: /ECBbus/
 File: ECBbus.sch

Title: SBC-188 version 3

Size: A4	Date: 2020-01-07	Rev: 3.1-004
KiCad E.D.A. kicad 5.1.5-52549c584ubuntu16.04.1		Id: 3/8

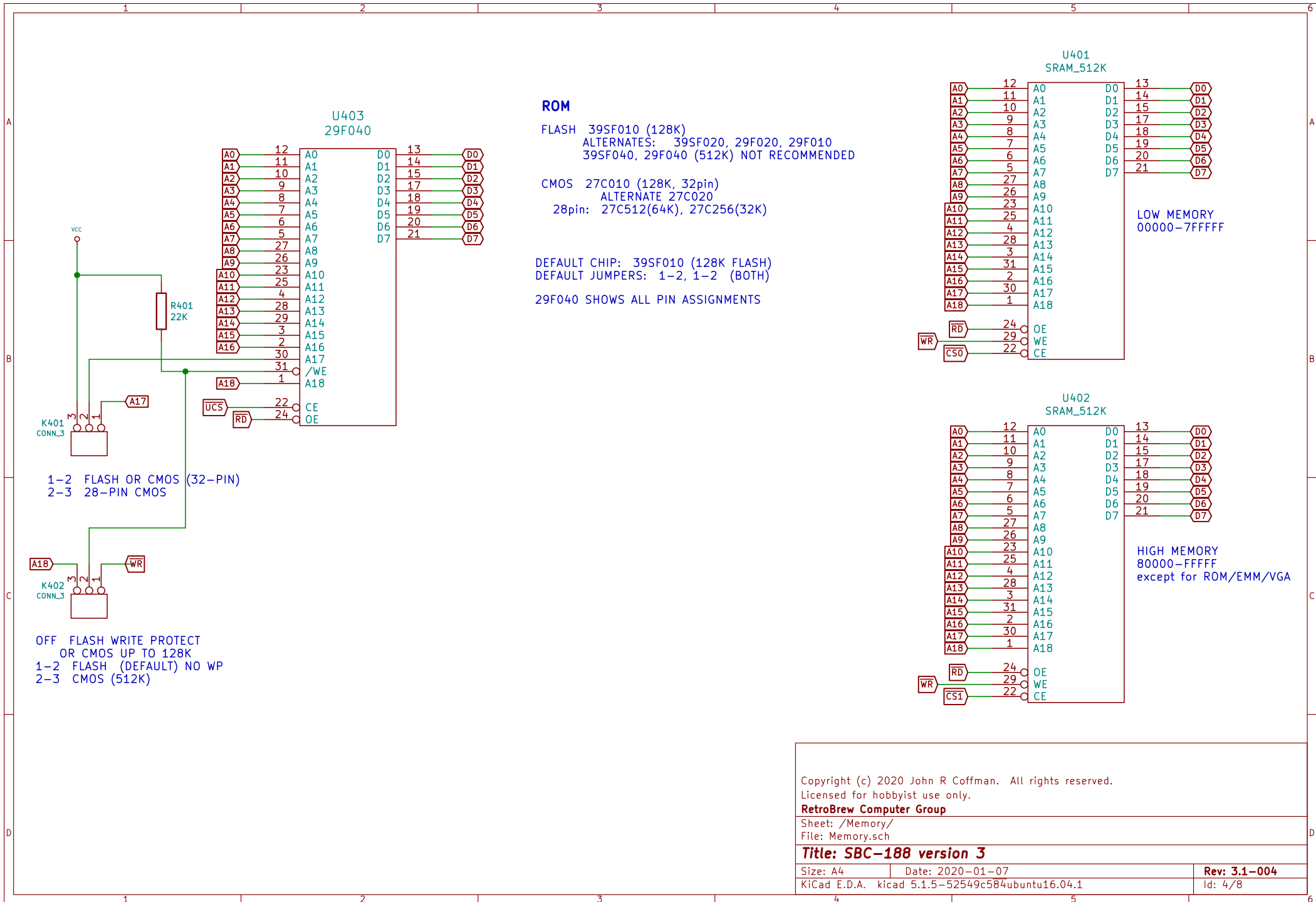

ROM

FLASH 39SF010 (128K)
 ALTERNATES: 39SF020, 29F020, 29F010
 39SF040, 29F040 (512K) NOT RECOMMENDED

CMOS 27C010 (128K, 32pin)
 ALTERNATE 27C020
 28pin: 27C512(64K), 27C256(32K)

DEFAULT CHIP: 39SF010 (128K FLASH)
 DEFAULT JUMPERS: 1-2, 1-2 (BOTH)
 29F040 SHOWS ALL PIN ASSIGNMENTS

U401
 SRAM_512K

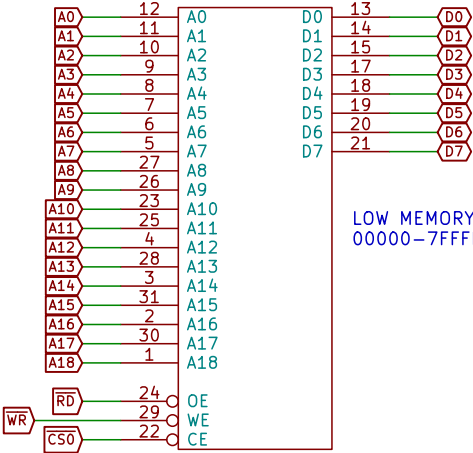

U402
 SRAM_512K

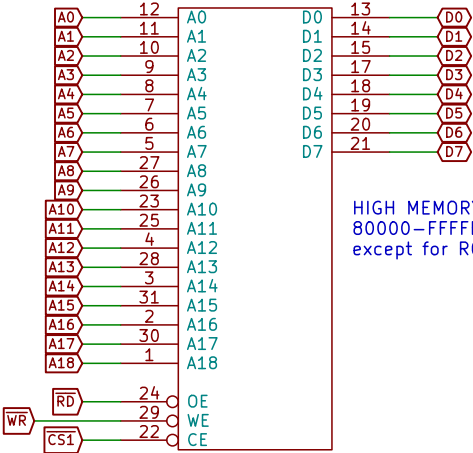

Copyright (c) 2020 John R Coffman. All rights reserved.
 Licensed for hobbyist use only.

RetroBrew Computer Group

Sheet: /Memory/
 File: Memory.sch

Title: SBC-188 version 3

Size: A4	Date: 2020-01-07	Rev: 3.1-004
KiCad E.D.A. kicad 5.1.5-52549c584ubuntu16.04.1		Id: 4/8

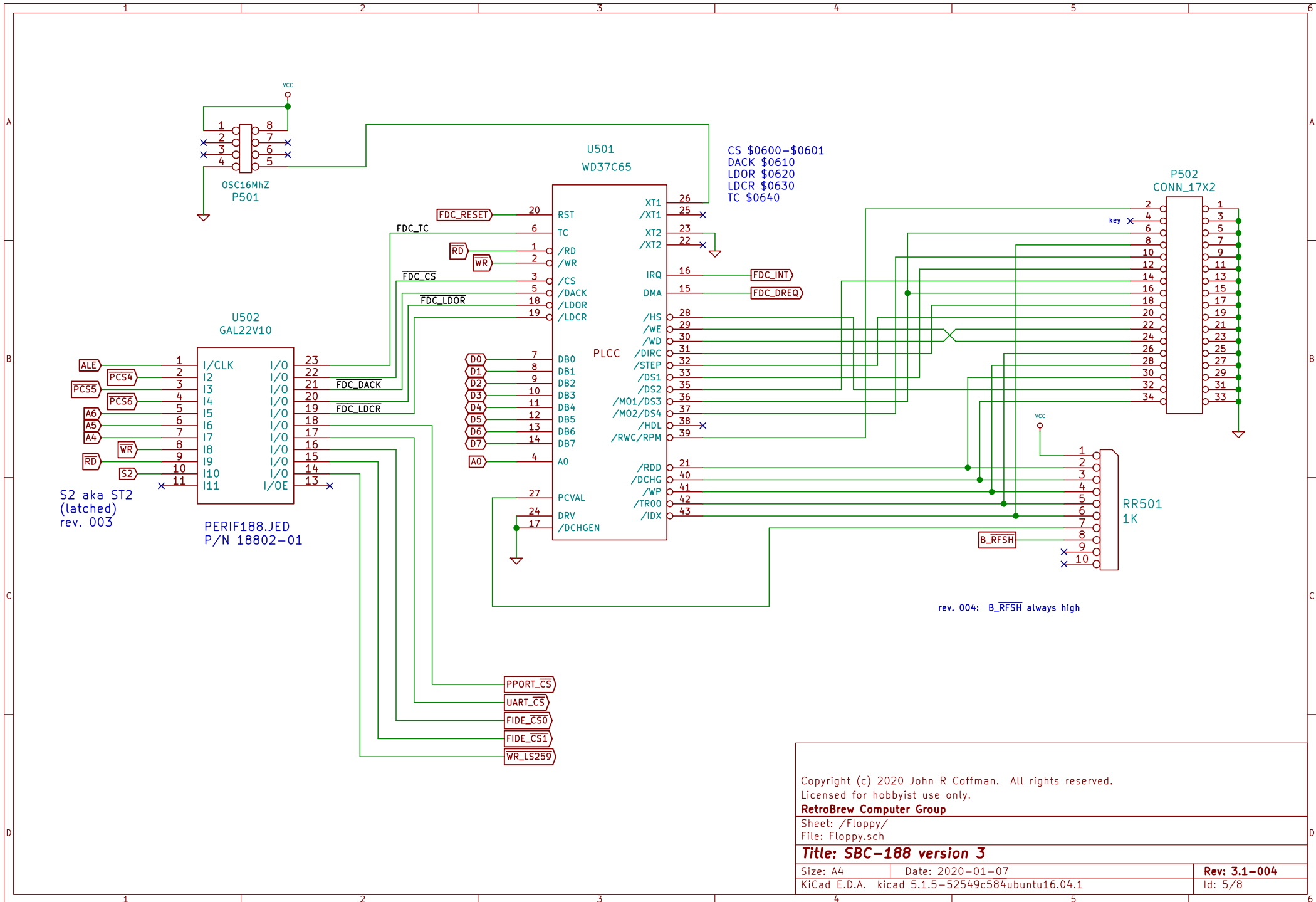

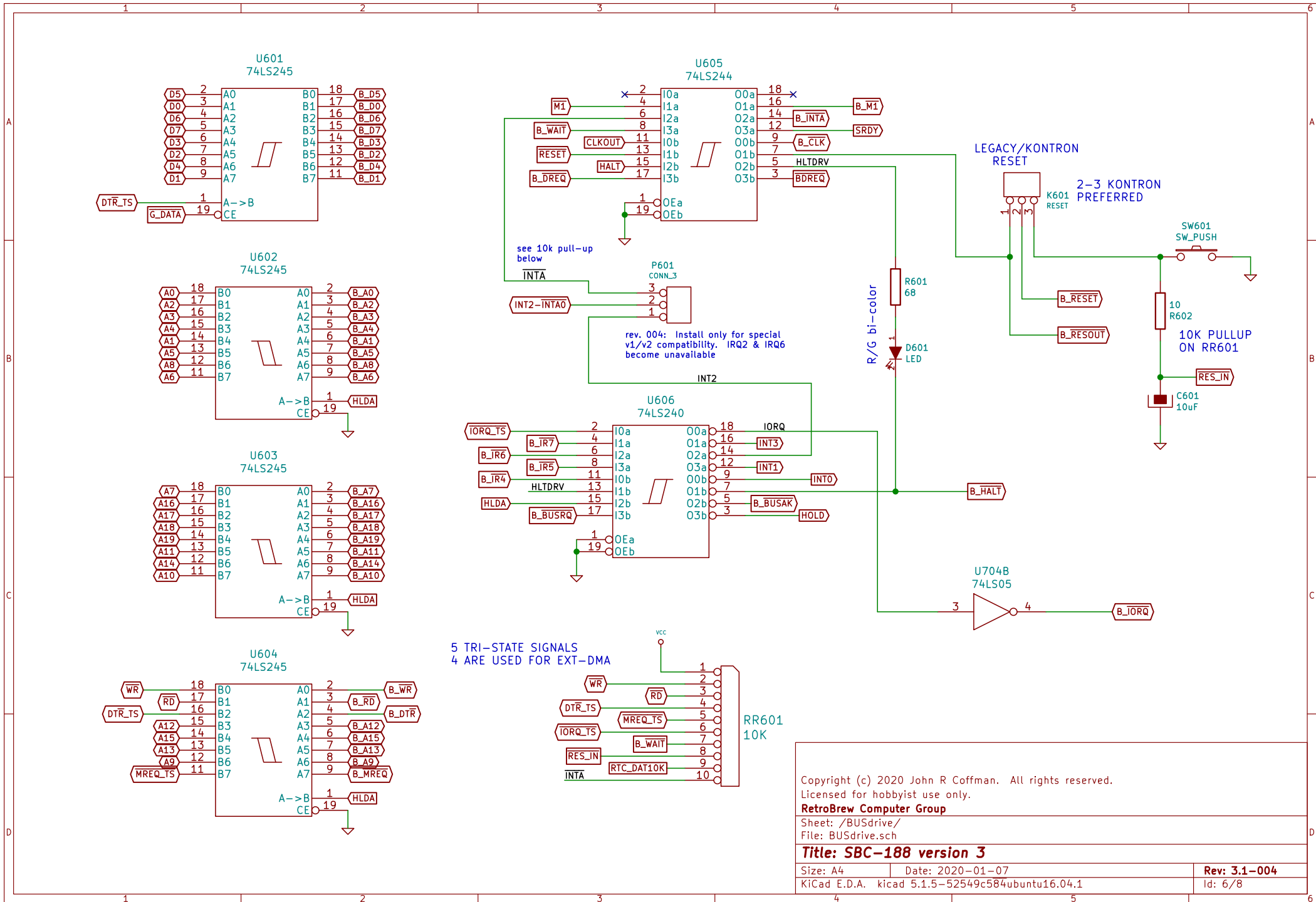

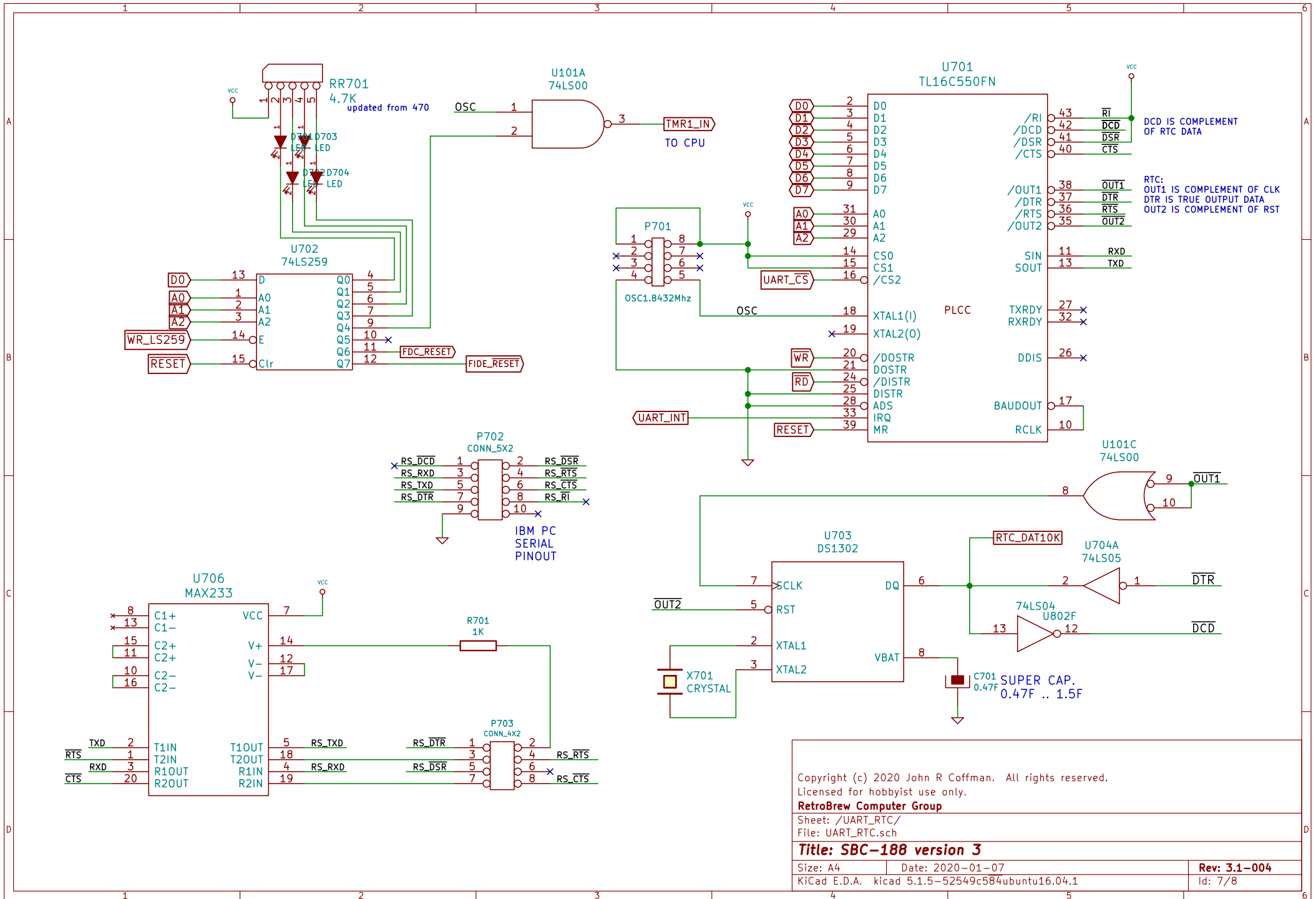

Copyright (c) 2020 John R Coffman. All rights reserved.
 Licensed for hobbyist use only.

RetroBrew Computer Group

Sheet: /UART_RTC/
 File: UART_RTC.sch

Title: SBC-188 version 3

Size: A4 | Date: 2020-01-07
 KiCad E.D.A. kicad 5.1.5-52549c584ubuntu16.04.1

Rev: 3.1-004
 Id: 7/8

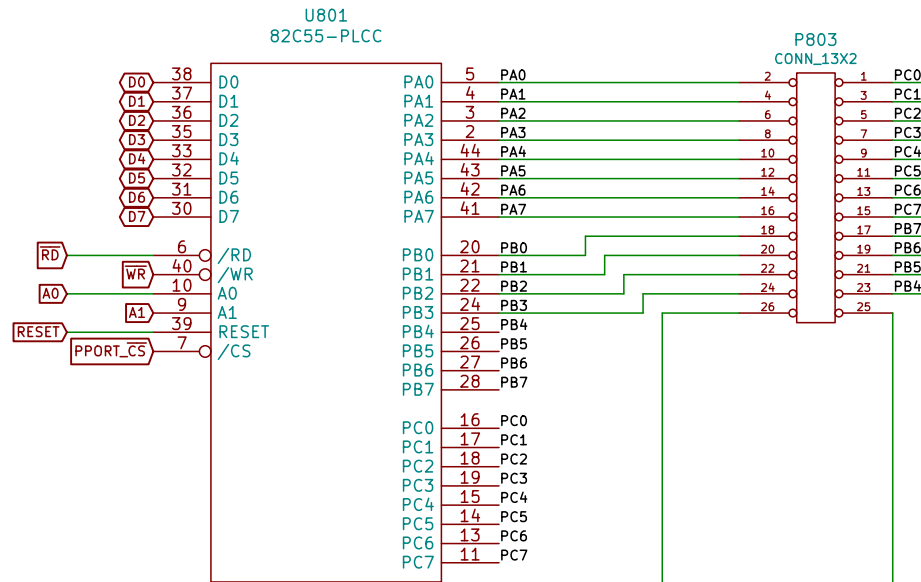

FROM LS259
ON UART_RTC

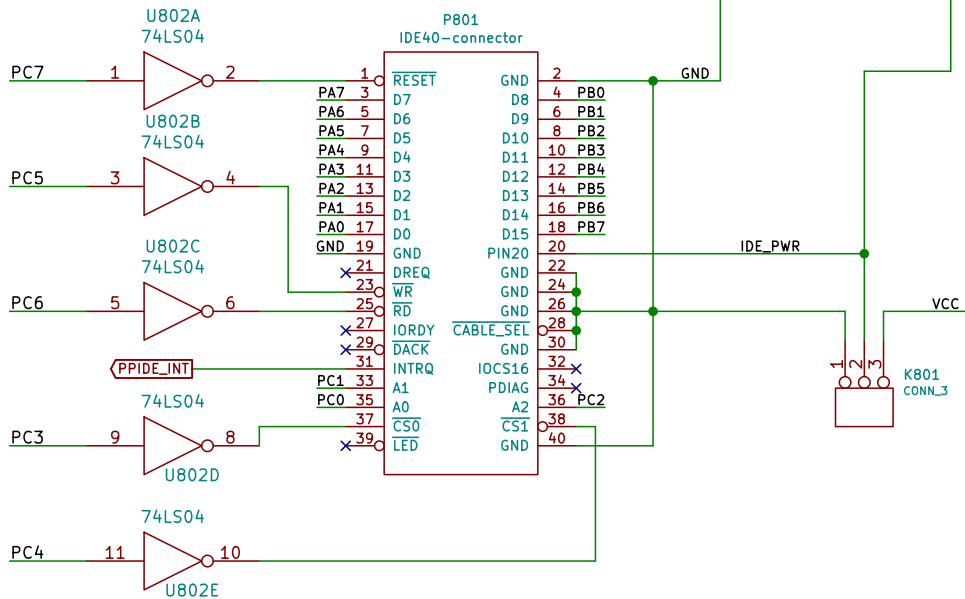
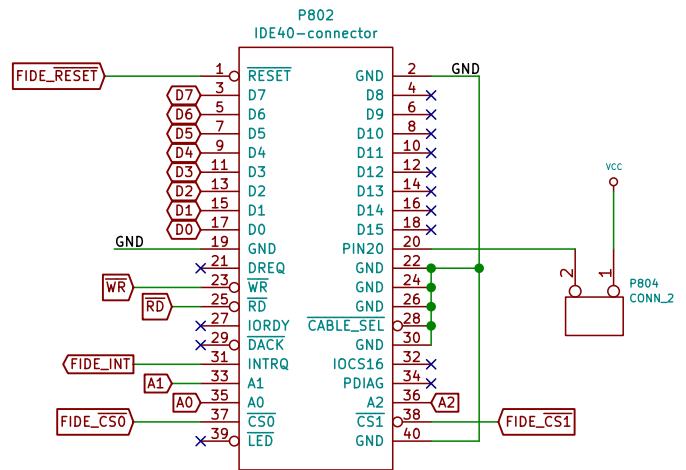

rev. 004: Interrupt sharing
rearranged
UART & FDC moved to v1/v2
locations

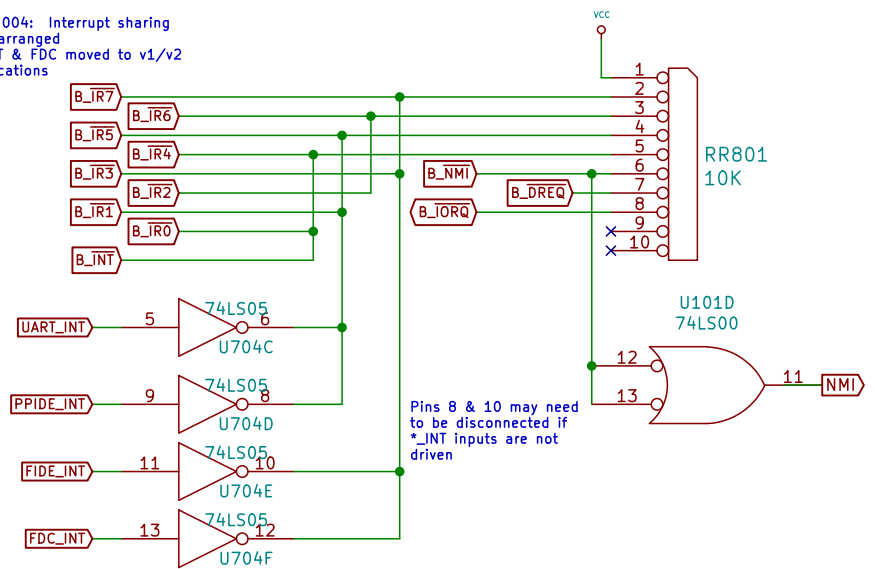

Copyright (c) 2020 John R Coffman. All rights reserved.
Licensed for hobbyist use only.

RetroBrew Computer Group

Sheet: /IDE_1_2/

File: IDE_1_2.sch

Title: SBC-188 version 3

Size: A4

Date: 2020-01-07

Rev: 3.1-004

KiCad E.D.A. kicad 5.1.5-52549c584ubuntu16.04.1

Id: 8/8