

DATA SHEET

P90CE201 16-bit microcontroller

Product specification
File under Integrated Circuits, IC21

August 1993

16-bit microcontroller**P90CE201****CONTENTS**

1	FEATURES	10	8-BIT GENERAL PORT
2	GENERAL DESCRIPTION	10.1	8-bit General Port registers
3	ORDERING INFORMATION	11	8-BIT AUXILIARY PORT
4	PINNING INFORMATION	11.1	8-bit Auxiliary Port registers
4.1	Pinning	12	WATCHDOG TIMER
4.2	Pin description	13	TIMERS
5	CPU FUNCTIONAL DESCRIPTION	13.1	General
5.1	General	13.2	Timer operating modes
5.2	5.2 Programming model and data organization	13.3	Timer registers
5.3	Internal and external operation	14	ELECTROMAGNETIC COMPATIBILITY (EMC) IMPROVEMENTS
5.4	Processing states and exception processing	15	ELECTRICAL SPECIFICATIONS
5.5	Stack format	15.1	Limiting values
5.6	CPU interrupt processing	15.2	DC Characteristics
6	SYSTEM CONTROL	15.3	AC Characteristics
6.1	Memory mapping	16	REGISTER MAP
6.2	Interrupt controller	17	PACKAGE OUTLINE
6.3	System Control Registers	18	SOLDERING
6.4	Reset	18.1	Introduction
6.5	Clock circuitry	18.2	Reflow soldering
7	INSTRUCTION SET	18.3	Wave soldering
7.1	Addressing modes	18.4	Repairing soldered joints
7.2	Instruction timing	19	DEFINITIONS
8	I ² C-BUS INTERFACE	20	LIFE SUPPORT APPLICATIONS
8.1	General	21	PURCHASE OF PHILIPS I ² C COMPONENTS
8.2	I ² C-bus interface registers		
9	UART SERIAL INTERFACE		
9.1	General		
9.2	Operating modes		
9.3	UART registers		



16-bit microcontroller

P90CE201

1 FEATURES

- CMOS technology
- Full 68000 software compatibility
- 32-bit internal structure
- 16-bit internal data transfer
- 8-bit access to external ROM/RAM
- External addressing range 16 Mbytes for ROM and 16 Mbytes for RAM
- Unused address pins can be used as quasi-bidirectional ports
- On-chip address decoder for ROM/RAM
- 8 edge triggered programmable interrupts that can also be used as quasi-bidirectional ports
- Reset control
- Built-in clock generator
- 2 fully independent fast I²C-bus serial interfaces
- UART serial interface (4 modes)
- 3 fully independent 16-bit timers
- Watchdog timer
- 8-bit quasi-bidirectional port, 4-bits with high drive capability
- EMC optimized layout and pinning
- 64-pin QFP package

2 GENERAL DESCRIPTION

The P90CE201 is a member of the P9XCXXX family of highly integrated 16-bit microcontrollers for use in a wide variety of applications. It is fully software compatible with the 68070/68000. The complete set of system functions available on the chip results in reduced system cost. Additionally, its modular design concept permits future extension to the family.

3 ORDERING INFORMATION

EXTENDED TYPE NUMBER	PACKAGE				CLOCK FREQUENCY (MHz)	TEMPERATURE RANGE (°C)
	PINS	PIN POSITION	MATERIAL	CODE		
P90CE201AEB	64	QFP	plastic	SOT319 ⁽¹⁾	24.0	-25 to 85

Note

1. SOT319-2; 1996 November 28.

16-bit microcontroller

P90CE201

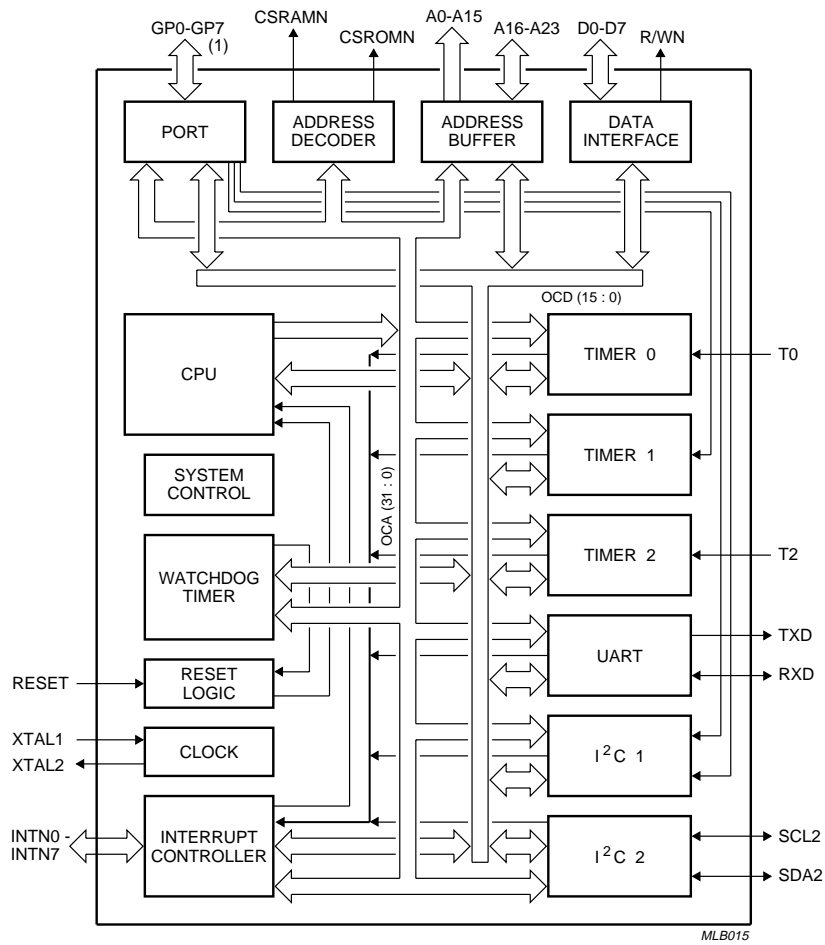

1. The General Port lines GP5, GP6 and GP7 have alternate functions for Timer 1, SCL1 and SDA1 respectively; see Table 1.

Fig.1 Block diagram

16-bit microcontroller

P90CE201

4 PINNING INFORMATION

4.1 Pinning

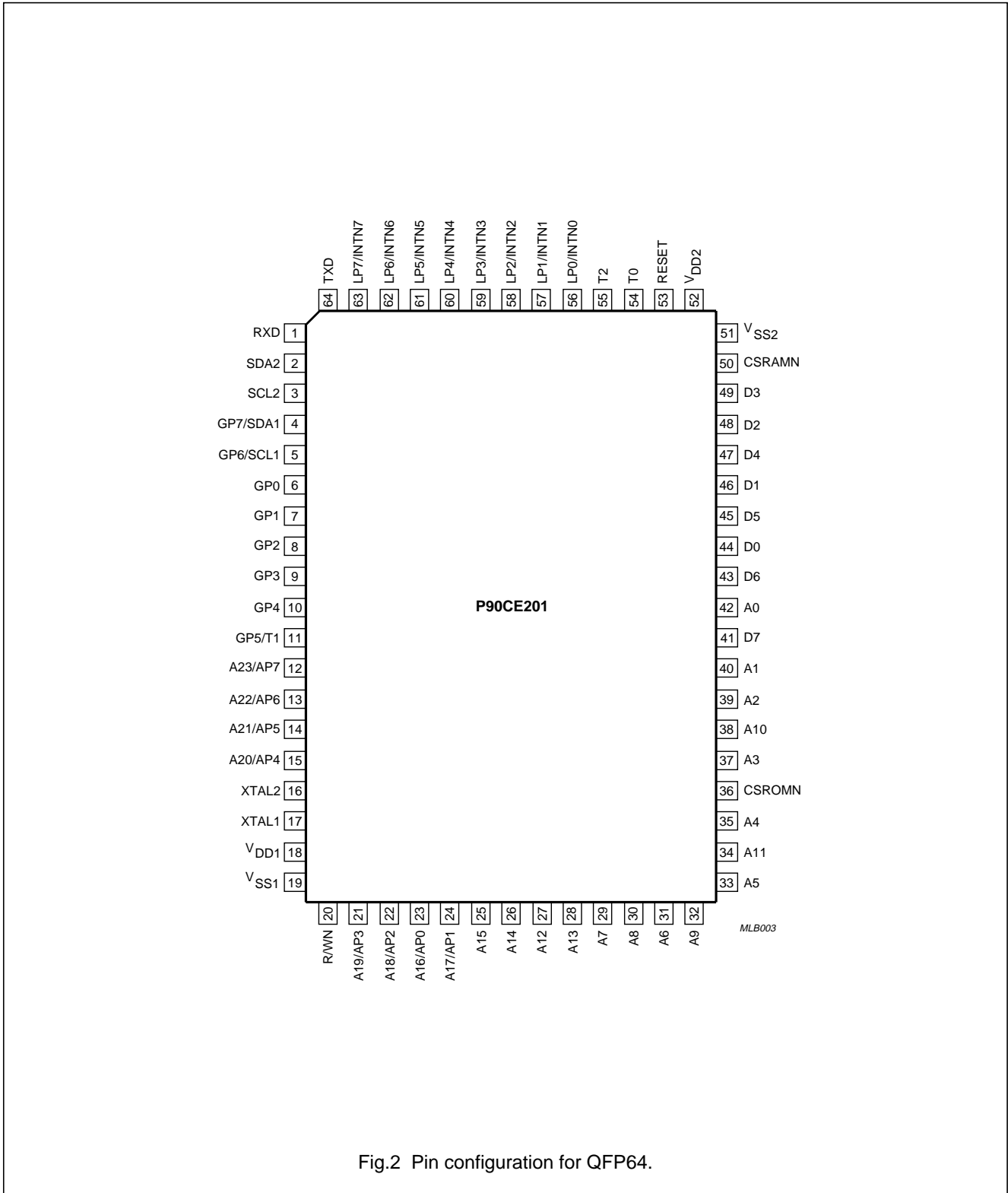

Fig.2 Pin configuration for QFP64.

16-bit microcontroller

P90CE201

4.2 Pin description

Table 1 QFP64 package.

MNEMONIC	TYPE	PIN NO.	FUNCTION
RXD	I/O	1	Receive Data. RXD is the data input for the UART interface.
SDA2	I/O	2	Serial Data 2 (open drain). SDA2 is the data signal for the second I ² C-bus serial interface.
SCL2	I/O	3	Serial Clock 2 (open drain). SCL2 is the clock signal for the second I ² C-bus serial interface.
GP7/SDA1 GP6/SCL1 GP0 GP1 GP2 GP3 GP4 GP5/T1	I/O	4 5 6 7 8 9 10 11	General Purpose Port (active HIGH, 3-state). The alternative functions are as follows. SCL1 is the clock signal for the first I ² C-bus serial interface. SDA1 is the data signal for the first I ² C-bus serial interface. T1 is the input pin for Timer 1.
A23/AP7 to A16/AP0	I/O	12 to 15, 21, 22, 24, 23	Address Bus. Upper 8-bits of the address bus (A23 to A16). The unused address bits can be selected as a quasi-bidirectional port (AP).
A15 to A0	O	25, 26, 28, 27, 34, 38, 32, 30, 29, 31, 33, 35, 37, 39, 40, 42	Address Bus. Lower 16-bits of the address bus.
XTAL2	O	16	Oscillator output. Not connected if an external clock generator is used.
XTAL1	I	17	Oscillator input. XTAL1 can also be used as an external clock input if an external clock generator is used.
V _{DD1}	–	18	Supply voltage. For internal logic, address bus, data bus, R/WN, CSRAMN, CSROMN, XTAL1 and XTAL2.
V _{SS1}	–	19	Ground. For internal logic, address bus, data bus, R/WN, CSRAMN, CSROMN, XTAL1 and XTAL2.
R/WN	O	20	Read (active HIGH)/ Write (active LOW). This controls the direction of data flow.
CSROMN	O	36	Chip Select ROM (active LOW). This signal selects external ROM.
D0 to D7	O	44, 46, 48, 49, 47, 45, 43, 41	Data Bus. 8-bit data bus.
CSRAMN	O	50	Chip Select RAM (active LOW). This signal enables external RAM.
V _{SS2}	–	51	Ground. For all other periphery pins (quiet port).
V _{DD2}	–	52	Supply voltage. For all other periphery pins (quiet port).
RESET	I	53	Reset (active HIGH). Input pin for an external reset.
T0	I	54	Timer 0. Input pin for cycle and event counting using Timer 0.
T2	I	55	Timer 2. Input pin for cycle and event counting using Timer 2.

16-bit microcontroller

P90CE201

MNEMONIC	TYPE	PIN NO.	FUNCTION
LP0/INTN0 LP1/INTN1 LP2/INTN2 LP3/INTN3 LP4/INTN4 LP5/INTN5 LP6/INTN6 LP7/INTN7	I/O	56 57 58 59 60 61 62 63	Latched Interrupt inputs (active LOW). A LOW level of ≥ 1 clock pulse will be stored as a pending interrupt request. Priority levels are programmable. Unused interrupt inputs can be used as a quasi-bidirectional port (LP).
TXD	O	64	Transmit Data. TXD is the data output for the UART serial interface.

16-bit microcontroller

P90CE201

5 CPU FUNCTIONAL DESCRIPTION

5.1 General

The CPU of the P90CE201 is software compatible with the 68000, consequently programs written for the 68000 will run on the P90CE201 unchanged. However, for certain applications the following differences between the processors should be noted:

- The initialization of the System Control Registers.
- Differences exist in the address error exception processing since the P90CE201 can provide full error recovery.
- The timing is different because of the P90CE201's new architecture and technology. The instruction execution timing is completely different for the same reason.

5.2 5.2 Programming model and data organization

The programming model is identical to that of the 68000 and is shown in Fig.3. It contains seventeen 32-bit registers, a 32-bit Program Counter and a 16-bit Status Register. The first eight registers (D0 to D7) are used as data registers for byte, word and long-word operations. The second group of registers (A0 to A6) and the System Stack Pointer (A7) can be used as software stack pointers and base address registers. In addition, these registers can be used for word and long-word address operations. All seventeen registers can be used as Index Registers.

The P90CE201 supports 8, 16 and 32-bit integer data, BCD data 32-bit addresses. Each data type is arranged in memory as shown in Fig.4.

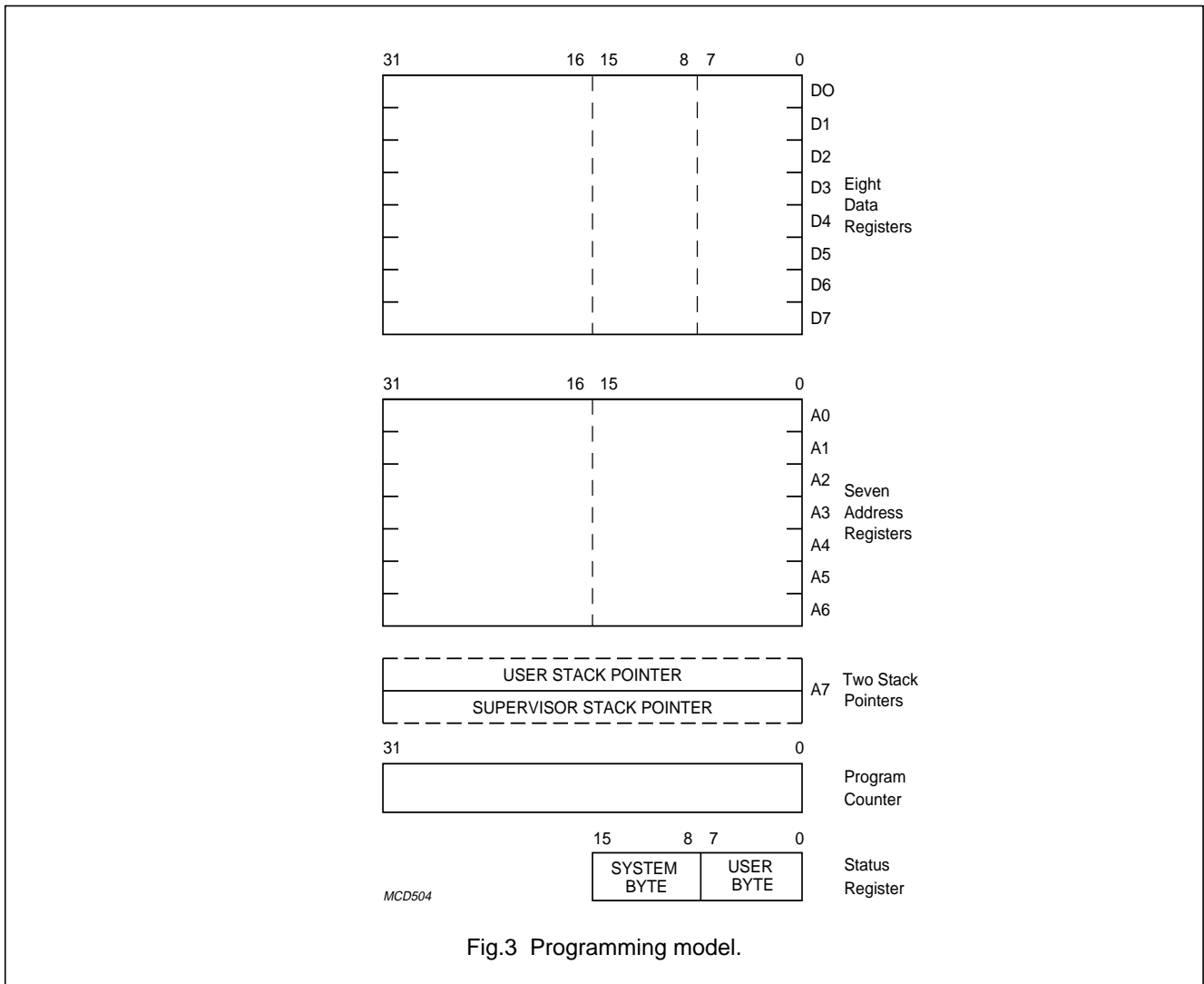
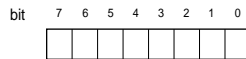

Fig.3 Programming model.

16-bit microcontroller

P90CE201



(a) Bit data (1 Byte = 8 bits).

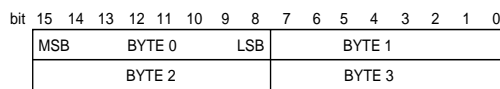

(b) Integer data (1 Byte = 8 bits).

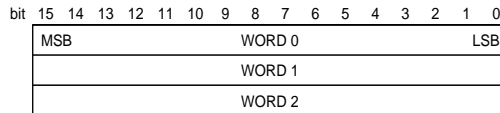

(c) Word data (16 bits).

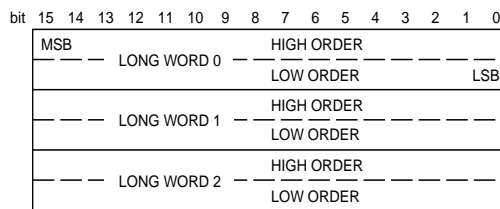

(d) Long-word data (32 bits).

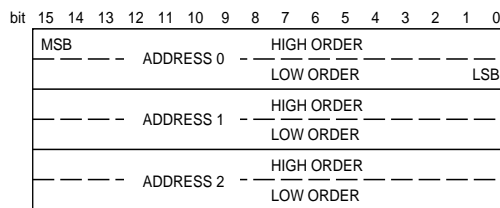

(e) Addresses (1 address =32 bits).

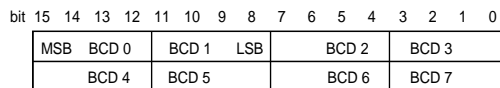

(f) BCD data (2 BCD digits = 1 Byte). MCD505

Fig.4 Memory data organization.

16-bit microcontroller

P90CE201

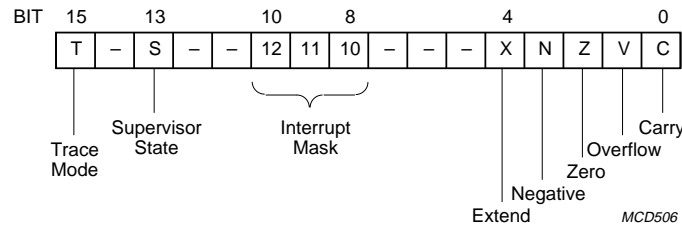

Fig.5 Status Register.

5.3 Internal and external operation

The P90CE201 operates with an internal clock frequency of half the oscillator frequency ($f_{OSC}/2$). Each internal clock cycle is divided into 2 states. A non-access machine cycle has 3 clock cycles or 6 states (S0 to S5). A minimum bus cycle normally consists of 3 clock cycles (6 states). When data transfer has not yet been terminated, wait states (SW) are inserted in multiples of 2. For external memory access, 2 wait states (bus states SB) are added automatically.

5.4 Processing states and exception processing

The CPU is always in one of three processing states: normal, exception or halted.

The normal processing state is that associated with instruction execution; the memory references are to fetch instructions and operands and to store results. A special case of the normal state is the stopped state which the processor enters when a STOP instruction is executed. In this state the CPU makes no further memory references.

The exception processing state is associated with interrupts, trap instructions, tracing and other exceptional conditions. The exception may be generated internally by an instruction or by an unusual condition arising during the execution of an instruction. Externally, exception processing can be forced by an interrupt or a reset.

The halted processing state is an indication of a catastrophic hardware failure. For example, if during exception processing of a bus error another bus error occurs, the CPU assumes that the system is unusable and halts. Only an external reset can restart a halted processor. Note that a CPU in the stopped state is not in the halted state or vice versa.

The processor can work in the “user” or “supervisor” state determined by the state of the S-bit in the Status Register. Accesses to the on-chip peripherals are achieved in the supervisor state.

All exception processing is performed in the supervisor state once the current content of the Status Register has been copied. The exception vector number is then determined and copies of the Status Register, the Program Counter value and the format/vector number are saved on the supervisor stack using the Supervisor Stack Pointer. Finally, the contents of the exception vector location is fetched and loaded into the Program Counter.

16-bit microcontroller

P90CE201

5.4.1 EXCEPTION VECTORS

Exception vectors are memory locations from which the CPU fetches the address of a routine that will handle that exception. All exception vectors are 2 words long (see Fig.6) except for the reset vector which is made up of 4 words, containing the Program Counter (PC) and the Supervisor Stack Pointer (SSP). All exception vectors are contained in the supervisor data space.

A vector number is an 8-bit number that, when multiplied by 4, gives the address of an exception vector. Vector numbers are generated internally. The memory map for the exception vectors is given in Table 2.

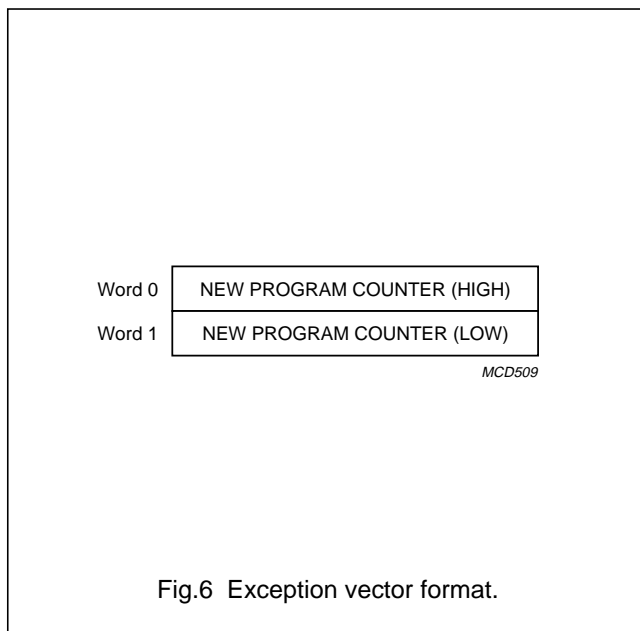

16-bit microcontroller

P90CE201

Table 2 Exception vector assignment.

VECTOR NO.	DEC	HEX	ASSIGNMENT
0	0	000	Reset: initial SSP
1	4	004	Reset: initial PC
2	8	008	Bus error
3	12	00C	Address error
4	16	010	Illegal instruction
5	20	014	Zero divide
6	24	018	CHK instruction
7	28	01C	TRAPV instruction
8	32	020	Privilege violation
9	36	024	Trace
10	40	028	Line 1010 emulator
11	44	02C	Line 1111 emulator
12	48	030	Unassigned, reserved
13 (note 1)	52	034	Unassigned, reserved
14	56	038	Format error
15	60	03C	Uninitialized interrupt vector
16 to 23 (note 1)	64 – 92	040 – 05C	Unassigned, reserved
24	96	060	Spurious interrupt
25	100	064	Level 1 on-chip interrupt autovector
26	104	068	Level 2 on-chip interrupt autovector
27	108	06C	Level 3 on-chip interrupt autovector
28	112	070	Level 4 on-chip interrupt autovector
29	116	074	Level 5 on-chip interrupt autovector
30	120	078	Level 6 on-chip interrupt autovector
31	124	07C	Level 7 on-chip interrupt autovector
32 to 47	128 – 188	080 – 0BC	TRAP instruction vectors
48 to 63 (note 1)	192 – 252	0C0 – 0FC	Unassigned, reserved
64 to 255	256 – 1020	100 – 3FC	User interrupt vectors

Note

1. Vectors 12, 13, 16 to 23 and 48 to 63 are reserved for future enhancements. No user peripheral devices should be assigned to these numbers.

16-bit microcontroller

P90CE201

5.4.2 MULTIPLE EXCEPTIONS

As two or more exceptions can occur simultaneously, exceptions are grouped in order of priority; as is shown in Table 3.

5.4.3 INSTRUCTION TRAPS

Traps are exceptions caused by instructions arising either from CPU recognition of abnormal conditions during instruction execution or from instructions whose normal behaviour is to cause traps.

Some instructions are used specifically to generate traps. The TRAP instruction always forces an exception, and is useful for implementing system calls for user programs. The TRAPV and CHK instructions force an exception if the user program detects a run-time error, possibly an arithmetic overflow or a subscript out of bounds. The signed divide (DIVS) and unsigned divide (DIVU) instructions will force an exception if a divide-by-zero operation is attempted.

5.4.4 ILLEGAL AND UNIMPLEMENTED INSTRUCTIONS

Illegal instruction is the term used to refer to any word that is not the first word of a legal instruction. During instruction execution, if such an instruction is fetched, an illegal instruction exception occurs. Words with bits 15 to 12 equal to 1010 or 1111 are defined as unimplemented instructions and separate exception vectors are allocated to these patterns for efficient emulation. This facility allows the operating system to detect program errors, or to emulate unimplemented instructions in software.

5.4.5 PRIVILEGE VIOLATIONS

To provide system security, various instructions are privileged and any attempt to execute one of the privileged and any attempt to execute one of the privileged instructions while the CPU is in the user state causes an exception. The privileged instructions are:

- STOP
- RESET
- RTE
- MOVE TO SR
- AND (word) immediate to SR
- EOR (word) immediate to SR
- OR (word) immediate to SR
- MOVE USP.

5.4.6 TRACING

The CPU includes a facility to trace instructions one by one to assist in program development. In the trace state, after each instruction is executed, an exception is forced so that a debugging program can monitor execution of the program under test.

The trace facility uses the T-bit in the supervisor part of the Status Register. If the T-bit is cleared, tracing is disabled and instructions execute normally. If the T-bit is set at the beginning of the execution of an instruction, a trace exception will be generated after that instruction is executed. If the instruction is not executed, either because of an interrupt, or because the instruction is illegal or privileged, the trace exception does not occur. Also, the trace exception does not occur if the instruction is aborted by a reset, bus error, or address error exception. If the instruction is executed and an interrupt is pending, the trace exception is processed before the interrupt. If the execution of an instruction forces an exception, the forced exception is processed before the trace exception.

As an extreme illustration of the above rules, consider the arrival of an interrupt during the execution of a TRAP instruction while tracing is enabled. First the trap exception is processed, then the trace exception, and finally the interrupt is processed. Instruction execution resumes in the interrupt handling routine.

Table 3 Exception grouping and priority.

GROUP	EXCEPTION	PROCESSING
0	RESET, ADDRESS ERROR BUS ERROR	Exception processing begins at the next machine cycle.
1	TRACE, INTERRUPT, ILLEGAL, PRIVILEGE	Exception processing begins before the next instruction.
2	TRAP, TRAPV, CHK, ZERO, DIVIDE, FORMAT ERROR	Exception processing is started through normal instruction execution.

16-bit microcontroller

P90CE201

5.5 Stack format

The stack format for exception processing is similar to the 68010 (rather than the 68000) although the information stored is not the same due to the different architecture. To handle this format the P90CE201 differs from the 68000 in that:

- The stack format has changed.
- The minimum number of words put into, or restored from, the stack is 4 (68010 compatible; not 3 as with the 68000).
- The RTE instruction decides (with the aid of the 4 format bits) whether or not more information has to be restored. The P90CE201 long format is used for bus error and address error exceptions; all other exceptions use the short format.
- If another format code, other than one of the two listed above, is detected during the restore action, a Format Error occurs.

If the user wants to finish the instruction in which the bus or address error occurred, the P90CE201 format must be used on RTE. If no changes to the stack are required during exception processing, the stack format is transparent to the user.

5.5.1 LONG AND SHORT STACK FORMATS

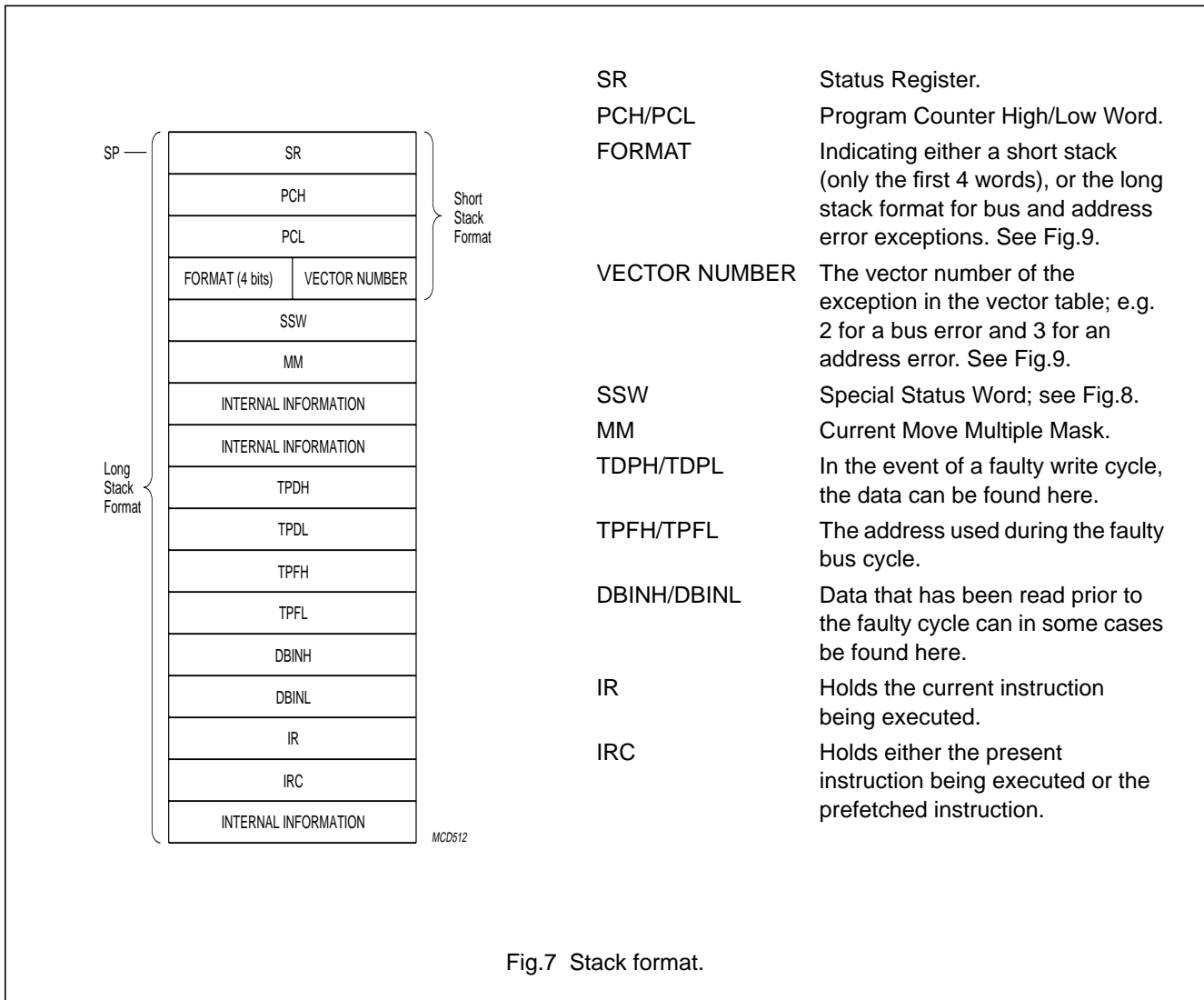

Fig.7 Stack format.

16-bit microcontroller

P90CE201

5.5.2 THE SPECIAL STATUS WORD (SSW)

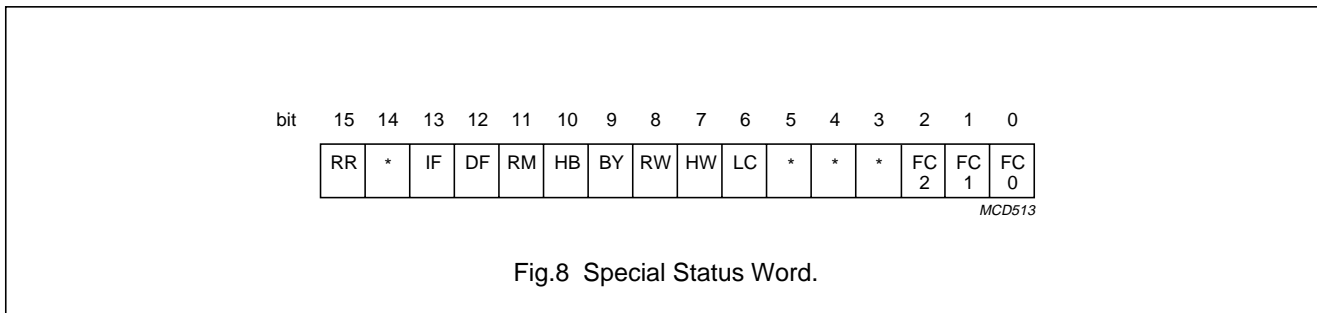

Table 4 Description of SSW.

SYMBOL	BIT	FUNCTION
RR	SSW.15	Rerun. By default this bit is a logic 0. If set to a logic 1, the CPU will not re-run the faulty bus cycle on return from exception (RTE).
–	SSW.14	Undefined, reserved
IF	SSW.13	The faulty cycle was an instruction fetch.
DF	SSW.12	The faulty cycle was a data fetch.
RM	SSW.11	The error occurred during a read-modify-write cycle.
HB	SSW.10	High Byte
BY	SSW.9	The faulty cycle was a byte transfer.
RW	SSW.8	Read/Write cycle
HW	SSW.7	High Word
LC	SSW.6	The faulty cycle was during a long-word access.
–	SSW.5	Undefined, reserved
–	SSW.4	Undefined, reserved
–	SSW.3	Undefined, reserved
FC2 FC1 FC0	SSW.2 SSW.1 SSW.0	Function Code. These three bits hold the internal function code during the faulty bus cycle. The function codes are the same as for the 68000 and affect the status of the CPU during the faulty bus cycle. See Table 5.

Table 5 Internal function codes.

FC2	FC1	FC0	ADDRESS SPACE
0	0	0	Reserved
0	0	1	User data
0	1	0	User program
0	1	1	Reserved
1	0	0	Reserved
1	0	1	Supervisor data
1	1	0	Supervisor program
1	1	1	Interrupt acknowledge

16-bit microcontroller

P90CE201

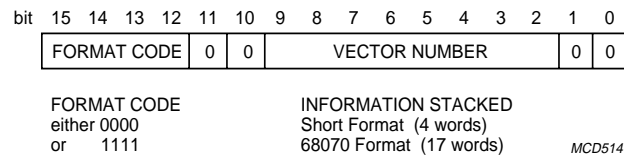

Fig.9 Vector number and format code.

5.6 CPU interrupt processing

An Interrupt Controller handles all interrupts, solves any priority problems and passes the highest level interrupt to the CPU. The general interrupt handling mechanism and the Interrupt Controller are described in section 6.2.

The CPU interrupt handling follows the same basic rules as in the 68000. However, the following changes have been made to simplify system development:

- Interrupts with a priority level equal to or less than the priority level actually running will not be accepted.
- During the acknowledge cycle of an interrupt, the IPL bits of the Status Register are set to the priority level of the acknowledged interrupt. An exception to this is when the IM bit in SYSCON2 is a logic 0. In this case level 7 is loaded into the Status Register. See section 6.1.2.

If the priority of the interrupt pending is greater than the current processor priority then:

- The exception processing sequence is started.
- A copy of the Status Register is saved.
- The privilege level is set to supervisor state.
- Tracing is suppressed.
- The priority level of the processor is set to that of the interrupt being acknowledged.

The processor then gets the vector number from the interrupting device, classifies it as an interrupt acknowledge, and displays the interrupt level number being acknowledged on the address bus.

If autovectoring is requested by the interrupting device, the processor internally generates a vector number that corresponds to the interrupt level number.

The processor then starts normal exception processing by saving the format word, Program Counter, and Status Register in the supervisor stack. The value of the vector in the format word is either supplied externally by the requesting device or is an internally generated vector number multiplied by four (format is all zeros). The Program Counter value is the address of the instruction that would have been executed if the interrupt had not been present. Then the interrupt vector contents are fetched and loaded into the Program Counter. The interrupt handling routine starts with normal instruction execution.

Priority level 7 is a special case; it can only be detected if the priority level was set to a lower value in between.

16-bit microcontroller

P90CE201

6 SYSTEM CONTROL

6.1 Memory mapping

The P90CE201 accesses the external ROM and RAM via 8 data lines and up to 24 address lines. Data access to or from the memories is bitwise. The data will be split or restructured internally to match the internal 16-bit data format. The upper byte (bits 15 to 8) of the data is taken from the even address, the lower byte (bits 7 to 0) from the odd address (MSB address + 1).

For external memory control the device provides the R/WN signal together with chip enable signals for ROM (CSROMN) and RAM (CSRAMN). CSROMN is activated in the internal address range 0H to FFFFFFFH. The CSRAMN signal is activated in the internal address range 1000000H to 1FFFFFFFH. In the external world RAM and ROM are wired in parallel with a maximum address range of 16 Mbytes each. If the larger memory of RAM or ROM is smaller than 16 Mbytes the unused address pins can be used as port pins. The advantages of this addressing scheme are:

- Maximum flexibility for RAM and ROM sizes.
- The full physical memory size can be used without any restrictions.
- The minimum number of address pins are used.

The validity of data is signalled to the CPU by the internal signal DTACKN. This signal is generated internally after a programmable delay (wait states). By programming the number of wait cycles the user can adapt the program execution times to his memory access times. After reset the delay for the DTACKN signal is set to its maximum value. Programming the number of wait cycles is described in section 6.3.2.

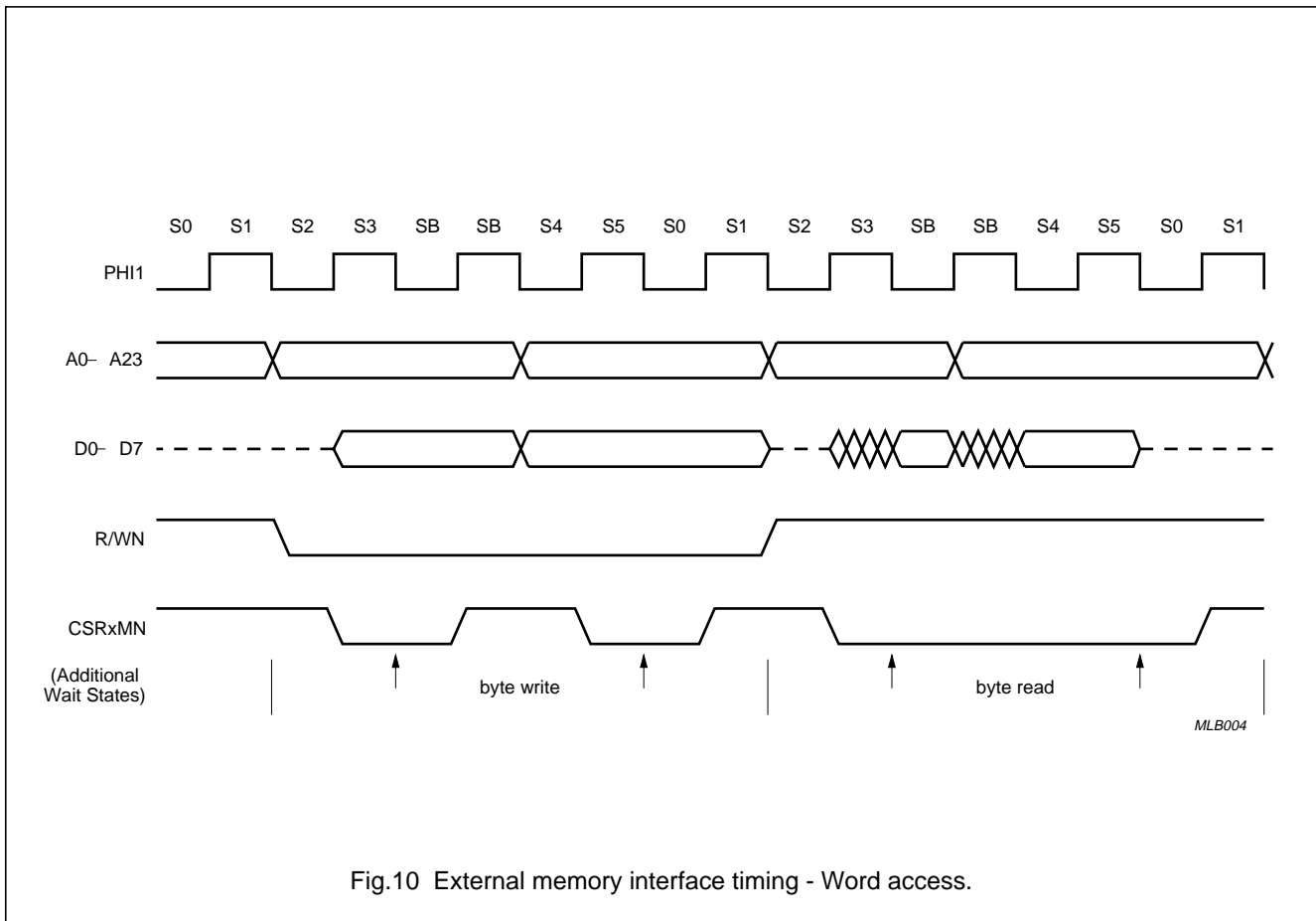

Fig.10 External memory interface timing - Word access.

16-bit microcontroller

P90CE201

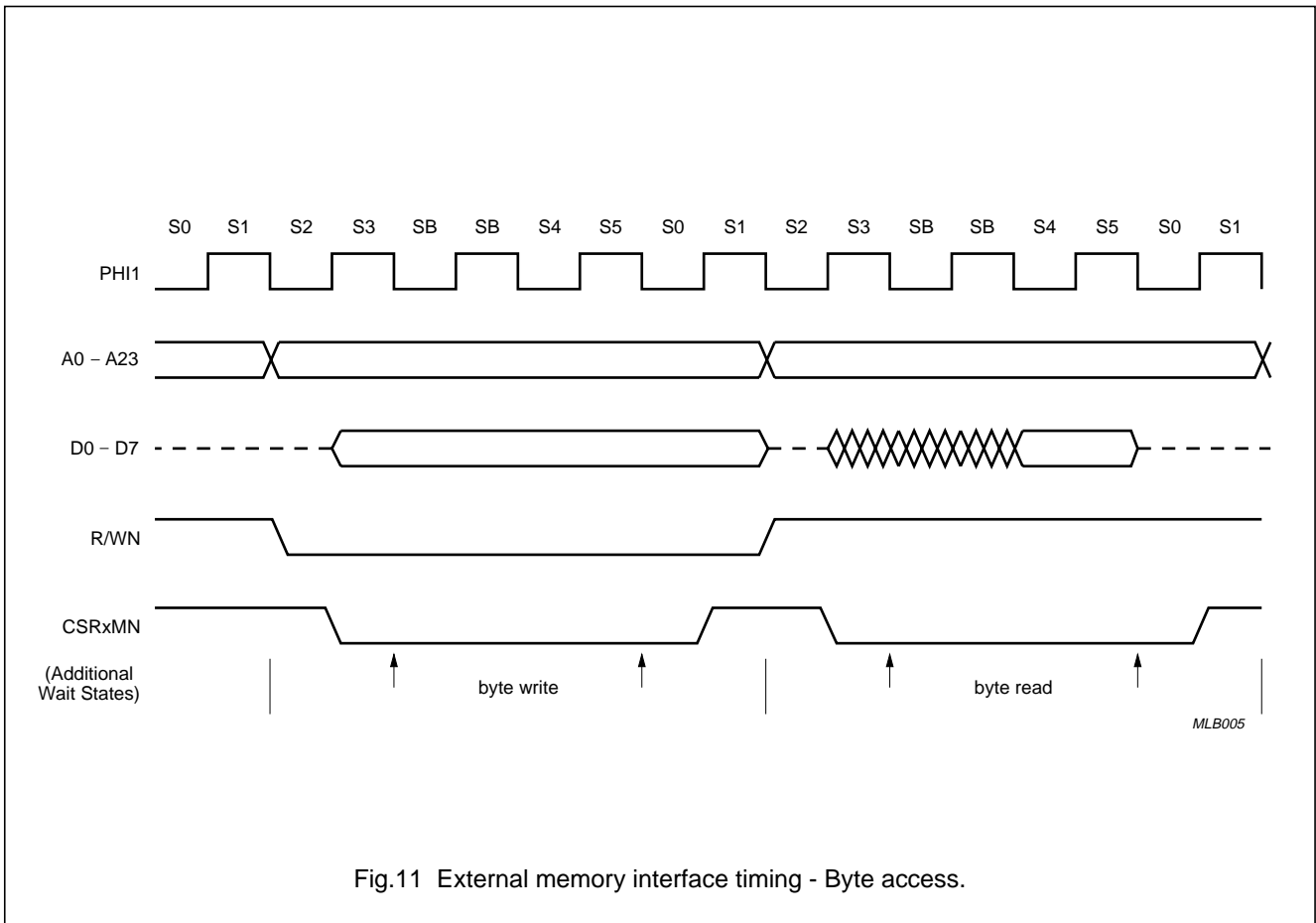

Fig.11 External memory interface timing - Byte access.

16-bit microcontroller

P90CE201

6.2 Interrupt controller

An interrupt controller handles all internal and external interrupts. It passes the interrupt with the highest level priority to the CPU.

The following interrupt requests are generated by the on-chip peripherals.

- I²C1
- I²C2
- UART receiver
- UART transmitter
- Timer 2
- Timer 1
- Timer 0.

The following interrupt requests are sent via external pins.

- INTN0 to INTN7

6.2.1 INTERRUPT ARBITRATION

The priority level of all interrupts are programmable and each may be allocated a value between 0 and 7. Level 7 has the highest priority, level 0 disables the corresponding interrupt source. In the event of interrupt requests of equal priority level occurring at the same time, then a hardware mechanism gives the following order.

- INTN7
- INTN6
- INTN5
- INTN4
- INTN3
- INTN2
- INTN1
- INTN0
- Timer 2
- Timer 1
- Timer 0
- UART receiver
- UART transmitter
- I²C2
- I²C1.

The execution of interrupt routines may be interrupted by another higher priority level interrupt request (nested interrupts). In the 68070 mode (SYSCON2.7 = 1), when an interrupt is serviced by the CPU, the corresponding level is loaded into the Status Register. This prevents the current interrupt from getting interrupted by another interrupt request with the same or lower priority level. If SYSCON2.7 = 0, priority level 7 will always be loaded into the Status Register and therefore the current interrupt cannot be interrupted by any other interrupt request.

6.2.2 ACKNOWLEDGE AND INTERRUPT VECTORS

When the CPU is ready to service a particular interrupt request, it initiates an "interrupt acknowledge cycle" in order to obtain the interrupt vector from the requesting device. When the device recognizes that its interrupt request has been accepted it either provides an 8-bit interrupt vector together with an internal DTACKN signal (vector mode), or it asserts an internal AVN signal and the interrupt vector is calculated from the interrupt level.

6.2.3 EXTERNAL LATCHED INTERRUPTS

INTN7 to INTN0 are 8 external interrupt inputs; each triggered on the falling edge of the input. Their priority levels as well as their interrupt vectors are programmable.

As an alternative function INTN7 to INTN0 may be used as I/O ports. When an interrupt pin is programmed as a port, the corresponding bit in the Port Control Register LPCRH (or LPCRL) is used for port I/O. A read from either of these two registers reads the value from the corresponding bit in the Port Control Register. A read from the Port Pad Control Register LPPH (or LPPL) reads the value from the corresponding port input pin. A write to LPCRH (or LPCRL) or to LPPH (or LPPL) writes the value to the corresponding port register, from where it is driven to the corresponding port pin.

The port function is configured as a quasi-bidirectional port. A bit is set to input mode by writing a logic 1 to the corresponding Port Control Register bit. This drives a "weak" logic 1 to the corresponding output pin, which can be overwritten by an external signal.

In the following register descriptions "n" represents the external interrupt number (0 to 7), its associated registers are identified using the same number.

16-bit microcontroller

P90CE201

6.2.4 LATCHED INTERRUPT REGISTER n (LIRn)

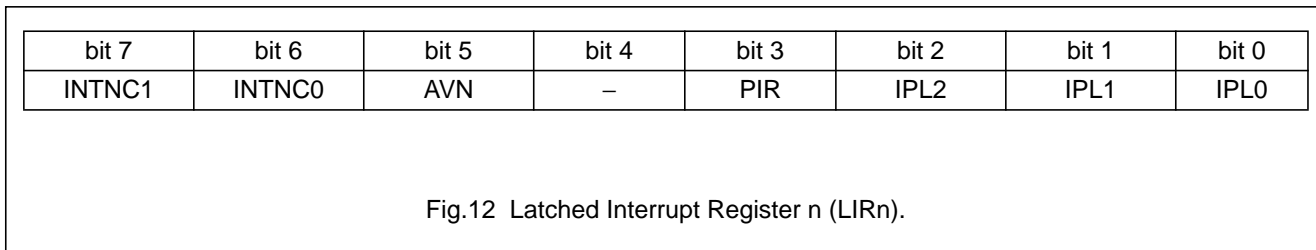

Table 6 Description of LIRn bits.

SYMBOL	BIT	FUNCTION
INTNC1 INTNC0	LIRn.7 LIRn.6	Interrupt Control. These two bits enable/disable the external interrupt INTNn, or select the pin as an I/O port. See Table 7.
AVN	LIRn.5	Autovector. When AVN = 0; INTNn is an autovectored interrupt and the processor calculates the appropriate vector from a fixed vector table. This is also the default value. When AVN = 1; INTNn is a vectored interrupt and the peripheral must provide an 8-bit vector number.
–	LIRn.4	Not used; reserved
PIR	LIRn.3	Pending Interrupt Request. If PIR = 1; then a valid interrupt request has been detected. It is automatically reset by the interrupt acknowledge cycle from the CPU. If PIR = 0; there is no pending interrupt request; this is also the default value. PIR can be set or reset by software by writing a logic 1 or logic 0 respectively to PIRn.
IPL2 IPL1 IPL0	LIRn.2 LIRn.1 LIRn.0	Interrupt Priority Level. These three bits select the interrupt priority level for the external interrupt INTNn. See Table 8.

Table 7 Interrupt INTNn control.

INTNC1	INTNC0	INTERRUPT CONTROL
0	0	Interrupt disabled; this is also the default value.
0	1	interrupt enabled
1	0	Interrupt pin is selected as an I/O port.
1	1	Reserved

Table 8 Selection of interrupt priority level.

IPL2	IPL1	IPL0	PRIORITY LEVEL
0	0	0	Interrupt inhibited; this is also the default value.
0	0	1	Level 1
0	1	0	Level 2
0	1	1	Level 3
1	0	0	Level 4
1	0	1	Level 5
1	1	0	Level 6
1	1	1	Level 7

16-bit microcontroller

P90CE201

6.2.5 LATCHED INTERRUPT VECTOR n (LIVn)

bit 7	bit 6	bit 5	bit 4	bit 3	bit 2	bit 1	bit 0
IV.7	IV.6	IV.5	IV.4	IV.3	IV.2	IV.1	IV.0

Fig.13 Latched Interrupt Vector n (LIVn).

Table 9 Description of LIVn bits.

SYMBOL	BIT	FUNCTION
IV.7 to IV.0	LIVn.7 to LIVn.0	8-bit interrupt vector number. The default value of this register is 0FH.

6.2.6 LATCHED PORT CONTROL REGISTER HIGH (LPCRHH)

bit 7	bit 6	bit 5	bit 4	bit 3	bit 2	bit 1	bit 0
INTN7	–	INTN6	–	INTN5	–	INTN4	–

Fig.14 Latched Port Control Register High (LPCRHH).

6.2.7 LATCHED PORT CONTROL REGISTER LOW (LPCRL)

bit 7	bit 6	bit 5	bit 4	bit 3	bit 2	bit 1	bit 0
INTN3	–	INTN2	–	INTN1	–	INTN0	–

Fig.15 Latched Port Control Register Low (LPCRL).

16-bit microcontroller

P90CE201

6.2.8 LATCHED PORT PIN REGISTER HIGH (LPPH)

bit 7	bit 6	bit 5	bit 4	bit 3	bit 2	bit 1	bit 0
INTN7	–	INTN6	–	INTN5	–	INTN4	–

Fig.16 Latched Port Pin Register High (LPPH).

6.2.9 LATCHED PORT PIN REGISTER LOW (LPPL)

bit 7	bit 6	bit 5	bit 4	bit 3	bit 2	bit 1	bit 0
INTN3	–	INTN2	–	INTN1	–	INTN0	–

Fig.17 Latched Port Pin Register Low (LPPL).

16-bit microcontroller

P90CE201

6.3 System Control Registers

The P90CE201 has two System Control Registers SYSCON1 and SYSCON2 which allow system parameters to be selected.

6.3.1 SYSTEM CONTROL REGISTER 1 (SYSCON1)

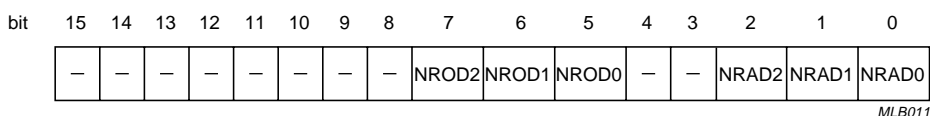

Fig.18 System Control Register 1 (SYSCON1).

Table 10 Description of SYSCON1 bits.

SYMBOL	BIT	FUNCTION
–	SYSCON1.15 to SYSCON1.8	These eight bits are not used.
NROD2 NROD1 NROD0	SYSCON1.7 SYSCON1.6 SYSCON1.5	These three bits select the access time for the ROM area. After a reset operation these bits are logic 0's. See Table 11.
–	SYSCON1.4	not used
–	SYSCON1.3	not used
NRAD2 NRAD1 NRAD0	SYSCON1.2 SYSCON1.1 SYSCON1.0	These three bits select the access time for the RAM area. After a reset operation these bits are logic 0's. See Table 11

Table 11 Selection of memory access times for ROM and RAM areas.

NRAD2	NRAD1	NRAD0	ADD WAIT STATES	f _{XTAL} (MHz)				UNIT
				24	20	16	12	
0	0	0	8	185	235	310	435	ns
0	0	1	4	101	135	185	268	ns
0	1	0	2	60	85	122	185	ns
0	1	1	0	18	35	60	101	ns

Notes

- 1 internal clock cycle contains 2 wait states.
- All other states are undefined and reserved.

16-bit microcontroller

P90CE201

6.3.2 SYSTEM CONTROL REGISTER 2 (SYSCON2)

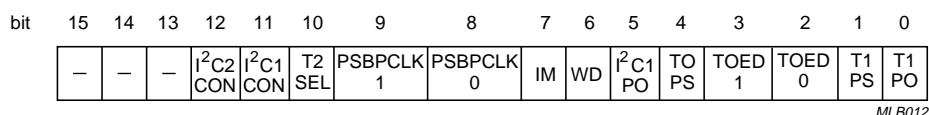

Fig.19 System Control Register 2 (SYSCON2).

Table 12 Description of SYSCON2 bits.

SYMBOL	BIT	FUNCTION
-	SYSCON2.15 to SYSCON2.13	These three bits are not used.
I ² C2CON	SYSCON2.12	This bit along with the three bits CR0, CR1 and CR2 held in the Serial Control Register (S2CON), are used to select the bitrate of the I ² C-bus 2 interface. If I ² C2CON = 0; the interface operates with a high bitrate. If I ² C2CON = 1; the interface operates with a low bitrate.
I ² C1CON	SYSCON2.11	This bit along with the three bits CR0, CR1 and CR2 held in the Serial Control Register (S1CON), are used to select the bitrate of the I ² C-bus 1 interface. If I ² C1CON = 0; the interface operates with a high bitrate. If I ² C1CON = 1; the interface operates with a low bitrate.
T2SEL	SYSCON2.10	This bit selects the frequency of the clock for Timer 2. If T2SEL = 0; the timer operates at a frequency of $f_{XTAL}/2$. If T2SEL = 1; the timer operates at a frequency of $BPCLK/4$.
PSBPCLK1 PSBPCLK0	SYSCON2.9 SYSCON2.8	These two bits control the prescaler for the basic peripheral clock. See Table 13.
IM	SYSCON2.7	If IM = 0; level 7 is loaded into the Status Register during interrupt processing to prevent the CPU from being interrupted by another interrupt source. If IM = 1; the current interrupt level is loaded into the Status Register allowing nested interrupts.
WD	SYSCON2.6	This bit enables or disables the Watchdog timer for bus error (internal) detection. If WD = 0; the timer is disabled. If WD = 1; the timer is enabled for bus error detection. If no acknowledge has been sent by the addressed device after 128×16 internal clock cycles the on-chip bus error signal is activated.
I ² C1PO	SYSCON2.5	The state of this bit determines whether general port pins GP.7/SDA1 and GP.6/SCL1 are used as port pins or in their I ² C-bus function. When I ² C1PO = 0; the port function is selected. When I ² C1PO = 1; the I ² C-bus is selected.
T0PS	SYSCON2.4	This bit enables or disables the prescaler for Timer 0. If T0PS = 0; the prescaler is disabled and the timer operates at a frequency of $f_{XTAL}/2$. If T0PS = 1; the prescaler is enabled and the timer operates at a frequency of $f_{XTAL}/32$.
TOED1 TOED0	SYSCON2.3 SYSCON2.2	These two bits select which transition at the external input will trigger an increment of Timer 0. See Table 14.

16-bit microcontroller

P90CE201

SYMBOL	BIT	FUNCTION
T1PS	SYSCON2.1	This bit enables or disables the prescaler for Timer 1. If T1PS = 0; the prescaler is disabled and the timer operates at a frequency of $f_{XTAL}/2$. If T1PS = 1; the prescaler is enabled and the timer operates at a frequency of $f_{XTAL}/32$.
T1PO	SYSCON2.0	This bit selects whether bit 5 of the general purpose port acts as a port or as an input to Timer 1. If T1PO = 0; bit 5 of the general purpose port acts as a port. If T1PO = 1; bit 5 of the general purpose port acts as an input to Timer 1.

Note

1. All bits of this register have a default value of logic 0 except TOED1 which has a default value of logic 1.

Table 13 Selection of basic peripheral clock for BPCLK = 4 MHz.

PSBPCLK1	PSBPCLK0	DIVISOR	f_{XTAL} (MHz)
0	0	3.0	24
0	1	2.5	20
1	0	2.0	16
1	1	1.5	12

Table 14 Selection of input trigger for T0.

TOED1	TOED0	TRANSITION
0	0	Edge detection disabled
0	1	LOW-to-HIGH transitions will be monitored.
1	0	HIGH-to-LOW transitions will be monitored. This is the default value after a reset operation.
1	1	Any transition will be monitored.

16-bit microcontroller

P90CE201

6.4 Reset

The reset input for the P90CE201 is RESET (pin 53). A Schmitt trigger is used at the input for noise rejection. The output of the Schmitt trigger is sampled by the reset circuitry every machine cycle. The internal reset circuitry has an additional input which is activated by an overflow of the Watchdog Timer (WDTIM). The On-chip Reset configuration is shown in Fig.20.

A global reset may be performed by three different methods:

- Applying an external signal to the RESET pin
- Automatic Power-on-reset circuitry
- Activated by an overflow of the Watchdog Timer.

During the reset operation the CPU and peripherals are reset. After an internal start-up time, the CPU reads the reset vectors (the reset vectors are four words long). Address 000000H is loaded into the Supervisor Stack Pointer (SSP), and address 000004H is loaded into the Program Counter (PC). As soon as the SSP and PC have been loaded, the CPU initializes the Status Register to interrupt level 7. Instruction execution then starts at the address indicated by the Program Counter.

6.4.1 EXTERNAL RESET USING THE RESET PIN

An external reset is accomplished by applying an external signal to the RESET pin. To ensure that the oscillator is stable before the controller starts, the external signal must be held HIGH for at least 100 ms.

6.4.2 AUTOMATIC POWER-ON RESET

Providing the rise time of V_{DD} does not exceed 10 ms, an automatic reset can be obtained by connecting the RESET pin to V_{DD} , via a 2.2 μF capacitor. When the power is switched on, the voltage on the RESET pin is equal to V_{DD} minus the capacitor voltage, and decreases from V_{DD} as the capacitor charges through the internal resistor (R_{RESET}) to ground. The larger the capacitor, the more slowly V_{RESET} decreases. V_{RESET} must remain above the lower threshold of the Schmitt trigger long enough to effect a complete reset. The time required is the oscillator start-up time, plus 2 machine cycles. The Power-on reset circuitry is shown in Fig.21.

6.4.3 RESET ACTIVATED BY AN OVERFLOW OF THE WATCHDOG TIMER

A reset can also be initiated by an overflow of the Watchdog Timer (see Fig.20). After a reset operation the Watchdog Timer is disabled.

Note that when the CPU executes a RESET instruction, the CPU is not affected, only the on-chip peripherals are reset.

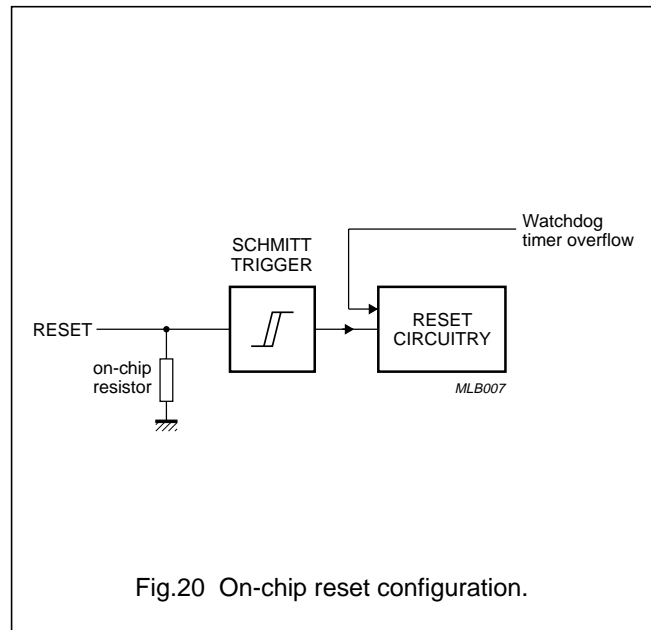

Fig.20 On-chip reset configuration.

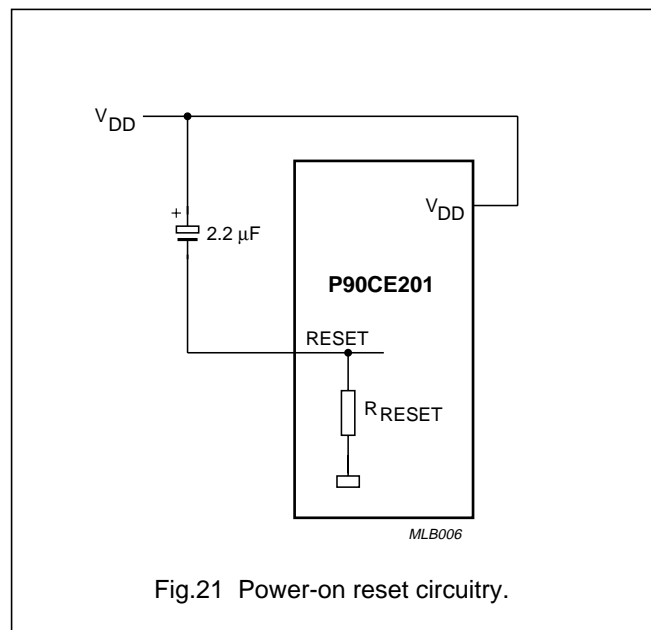

Fig.21 Power-on reset circuitry.

16-bit microcontroller

P90CE201

6.5 Clock circuitry

The oscillator circuit of the P90CE201 is a single-stage inverting amplifier in a Pierce oscillator configuration. The circuitry between XTAL1 and XTAL2 is basically an inverter biased to the transfer point. Either a crystal or ceramic resonator can be used as the feedback element to complete the oscillator circuitry. Both are operated in parallel resonance. XTAL1 is the high gain amplifier input, and XTAL2 is the input; see Fig.22. To drive the P90CE201 externally, XTAL1 is driven from an external source and XTAL2 left open-circuit; see Fig.23.

The P90CE201 is specified for a maximum crystal frequency of 24 MHz. The internal clock frequency is the crystal frequency (f_{XTAL}) divided by 2. For some peripherals such as the UART and Watchdog Timer, a main prescaler generates a basic peripheral clock. Frequencies other than the basic peripheral clock will be generated within the peripherals. The prescaler is programmed by register SYSCON2. Table 15 shows the frequencies of the basic peripheral clock generated by the main prescaler.

Table 15 Basic peripheral clock frequencies.

f_{XTAL} (MHz)	f_{INT} (MHz)	f_{INT} DIVISOR (MHz)			
		3	2.5	2	1.5
24	12	4.00	4.80	6.00	8.00
20	10	3.33	4.00	5.00	6.66
16	8	2.66	3.20	4.00	5.33
12	6	2.00	2.40	3.00	4.00

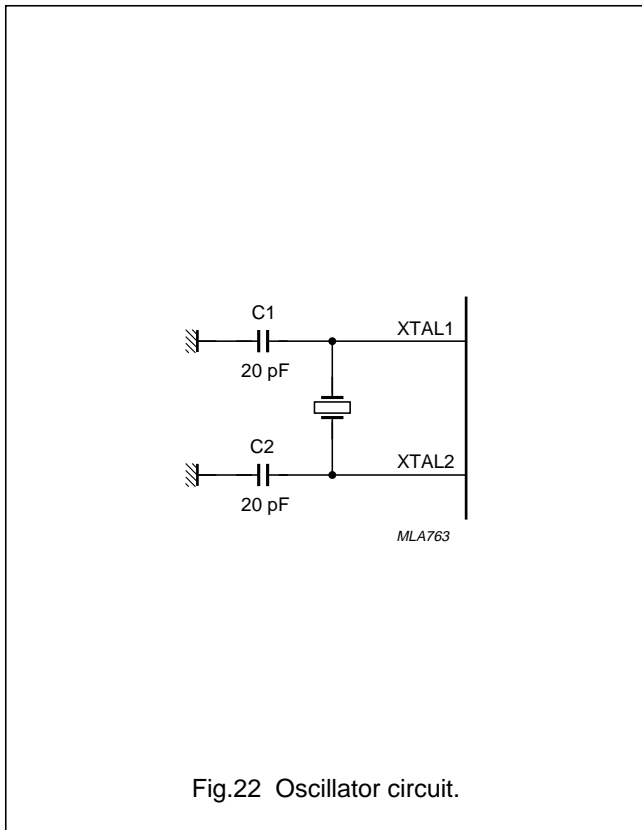

Fig.22 Oscillator circuit.

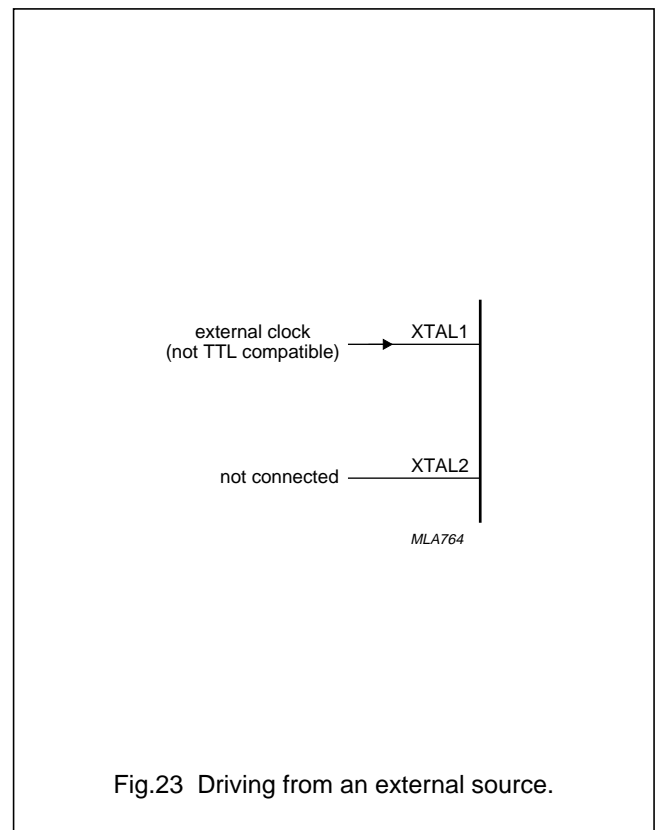

Fig.23 Driving from an external source.

16-bit microcontroller

P90CE201

7 INSTRUCTION SET

The P90CE201 is completely code compatible with the 68000. Consequently, programs developed for the 68000 will run on the P90CE201. This applies to both the source and object codes. The instruction set was designed to minimize the number of mnemonics that the programmer has to remember.

MNEMONIC	DESCRIPTION	OPERATION	CONDITION CODES				
			X	N	Z	V	C
ABCD	Add Decimal with Extend	$(\text{Destination})_{10} + (\text{Source})_{10} + X \rightarrow \text{Destination}$	*	U	*	U	*
ADD	Add Binary	$(\text{Destination}) + (\text{Source}) \rightarrow \text{Destination}$	*	*	*	*	*
ADDA	Add Address	$(\text{Destination}) + (\text{Source}) \rightarrow \text{Destination}$	–	–	–	–	–
ADDI	Add Immediate	$(\text{Destination}) + \text{Immediate Data} \rightarrow \text{Destination}$	*	*	*	*	*
ADDQ	Add Quick	$(\text{Destination}) + \text{Immediate Data} \rightarrow \text{Destination}$	*	*	*	*	*
ADDX	Add Extended	$(\text{Destination}) + (\text{Source}) + X \rightarrow \text{Destination}$	*	*	*	*	*
AND	AND Logical	$(\text{Destination}) \wedge (\text{Source}) \rightarrow \text{Destination}$	–	*	*	0	0
ANDI	AND Immediate	$(\text{Destination}) \wedge \text{Immediate Data} \rightarrow \text{Destination}$	–	*	*	0	0
ASL, ASR	Arithmetic Shift	$(\text{Destination}) \text{ Shifted by } \langle \text{count} \rangle \rightarrow \text{Destination}$	*	*	*	*	*
Bcc	Branch Conditionally	If CC then $\text{PC} + d \rightarrow \text{PC}$	–	–	–	–	–
BCHG	Test a Bit and Change	$\sim(\langle \text{bit number} \rangle) \text{ of Destination} \rightarrow Z$ $\sim(\langle \text{bit number} \rangle) \text{ of Destination} \rightarrow$ $\langle \text{bit number} \rangle \text{ of Destination}$	–	–	*	–	–
BCLR	Test a Bit and Clear	$\sim(\langle \text{bit number} \rangle) \text{ of Destination} \rightarrow Z$	–	–	*	–	–
BRA	Branch Always	$\text{PC} + d \rightarrow \text{PC}$	–	–	–	–	–
BSET	Test a Bit and Set	$\sim(\langle \text{bit number} \rangle) \text{ of Destination} \rightarrow Z$ $1 \rightarrow \langle \text{bit number} \rangle \text{ of Destination}$	–	–	*	–	–
BSR	Branch to Subroutine	$\text{PC} \rightarrow \text{SP} @ -; \text{PC} + d \rightarrow \text{PC}$	–	–	–	–	–
BTST	Test a Bit	$\sim(\langle \text{bit number} \rangle) \text{ of Destination} \rightarrow Z$	–	–	*	–	–
CHK	Check Register against Bounds	If $D_n < 0$ or $D_n > (\langle \text{source} \rangle)$ then TRAP	–	*	U	U	U
CLR	Clear an Operand	$0 \rightarrow \text{Destination}$	–	0	1	0	0
CMP	Compare	$(\text{Destination}) - (\text{Source})$	–	*	*	*	*
CMPA	Compare Address	$(\text{Destination}) - (\text{Source})$	–	*	*	*	*
CMPI	Compare Immediate	$(\text{Destination}) - \text{Immediate Data}$	–	*	*	*	*
CMPM	Compare Memory	$(\text{Destination}) - (\text{Source})$	–	*	*	*	*
DBcc	Test Condition, Decrement & Branch	If (not CC) then $D_n - 1 \rightarrow D_n$; if $D_n \neq -1$ then $\text{PC} + d \rightarrow \text{PC}$	–	–	–	–	–
DIVS	Signed Divide	$(\text{Destination}) / (\text{Source}) \rightarrow \text{Destination}$	–	*	*	*	0
DIVU	Unsigned Divide	$(\text{Destination}) / (\text{Source}) \rightarrow \text{Destination}$	–	*	*	*	0

16-bit microcontroller

P90CE201

MNEMONIC	DESCRIPTION	OPERATION	CONDITION CODES				
			X	N	Z	V	C
EOR	Exclusive OR Logical	(Destination) \oplus (Source) \rightarrow Destination	–	*	*	0	0
EORI	Exclusive OR Immediate	(Destination) \oplus Immediate Data \rightarrow Destination	–	*	*	0	0
EXG	Exchange Register	Rx \leftrightarrow Ry	–	–	–	–	–
EXT	Sign Extend	(Destination) Sign – extended \rightarrow Destination	–	*	*	0	0
JMP	Jump	Destination \rightarrow PC	–	–	–	–	–
JSR	Jump to Subroutine	PC \rightarrow SP @ – ; Destination \rightarrow PC	–	–	–	–	–
LEA	Load Effective Address	Destination \rightarrow An	–	–	–	–	–
LINK	Link and Allocate	An \rightarrow SP @ – ; SP \rightarrow An; SP + d \rightarrow SP	–	–	–	–	–
LSL, LSR	Logical Shift	(Destination) Shifted by < count > \rightarrow Destination	*	*	*	0	*
MOVE	Move Data from Source to Destination	(Source) \rightarrow Destination	–	*	*	0	0
MOVE to CCR	Move to Condition Code	(Source) \rightarrow CCR	*	*	*	*	*
MOVE to SR	Move to the Status Register	(Source) \rightarrow SR	*	*	*	*	*
MOVE from SR	Move from the Status Register	SR \rightarrow Destination	–	–	–	–	–
MOVE USP	Move User Stack Pointer	USP \rightarrow An; An \rightarrow USP	–	–	–	–	–
MOVEA	Move Address	(Source) \rightarrow Destination	–	–	–	–	–
MOVEM	Move Multiple Registers	Registers \rightarrow Destination; (Source) \rightarrow Registers	–	–	–	–	–
MOVEP	Move Peripheral Data	(Source) \rightarrow Destination	–	–	–	–	–
MOVEQ	Move Quick	Immediate Data \rightarrow Destination	–	*	*	0	0
MULS	Signed Multiply	(Destination) * (Source) \rightarrow Destination	–	*	*	*	0
MULU	Unsigned Multiply	(Destination) * (Source) \rightarrow Destination	–	*	*	*	0
NBCD	Negate Decimal with Extend	0 – (Destination) ₁₀ – X \rightarrow Destination	*	U	*	U	*
NEG	Negate	0 – (Destination) \rightarrow Destination	*	*	*	*	*
NEGX	Negate with Extend	0 – (Destination) – X \rightarrow Destination	*	*	*	*	*
NOP	No Operation	–	–	–	–	–	–

16-bit microcontroller

P90CE201

MNEMONIC	DESCRIPTION	OPERATION	CONDITION CODES				
			X	N	Z	V	C
NOT	Logical Complement	$\sim(\text{Destination}) \rightarrow \text{Destination}$	–	*	*	0	0
OR	Inclusive OR Logical	$(\text{Destination}) \vee (\text{Source}) \rightarrow \text{Destination}$	–	*	*	0	0
ORI	Inclusive OR Immediate	$(\text{Destination}) \vee \text{Immediate Data} \rightarrow \text{Destination}$	–	*	*	0	0
PEA	Push Effective Address	$\text{Destination} \rightarrow \text{SP} @ -$	–	–	–	–	–
RESET	Reset External Devices	–	–	–	–	–	–
ROL, ROR	Rotate (Without Extend)	$(\text{Destination}) \text{ Rotated by } \langle \text{count} \rangle \rightarrow \text{Destination}$	–	*	*	0	*
ROXL, ROXR	Rotate with Extend	$(\text{Destination}) \text{ Rotated by } \langle \text{count} \rangle \rightarrow \text{Destination}$	*	*	*	0	*
RTE	Return from Exception	$\text{SP} @ + \rightarrow \text{SR}; \text{SP} @ + \rightarrow \text{PC}$	*	*	*	*	*
RTR	Return and Restore Condition Codes	$\text{SP} @ + \rightarrow \text{SR}; \text{SP} @ + \rightarrow \text{PC}$	*	*	*	*	*
RTS	Return from Subroutine	$\text{SP} @ + \rightarrow \text{PC}$	–	–	–	–	–
SBCD	Subtract Decimal with Extend	$(\text{Destination})_{10} - (\text{Source})_{10} - X \rightarrow \text{Destination}$	*	U	*	U	*
S _{CC}	Set According to Condition	if CC then 1 \rightarrow Destination; else 0 \rightarrow Destination	–	–	–	–	–
STOP	Load Status Register and Stop	Immediate Data \rightarrow SR; STOP	*	*	*	*	*
SUB	Subtract Binary	$(\text{Destination}) - (\text{Source}) \rightarrow \text{Destination}$	*	*	*	*	*
SUBA	Subtract Address	$(\text{Destination}) - (\text{Source}) \rightarrow \text{Destination}$	–	–	–	–	–
SUBI	Subtract Immediate	$(\text{Destination}) - \text{Immediate Data} \rightarrow \text{Destination}$	*	*	*	*	*
SUBQ	Subtract Quick	$(\text{Destination}) - \text{Immediate Data} \rightarrow \text{Destination}$	*	*	*	*	*
SUBX	Subtract with Extend	$(\text{Destination}) - (\text{Source}) - X \rightarrow \text{Destination}$	*	*	*	*	*
SWAP	Swap Register Halves	Register [31:16] \leftrightarrow Register [15:0]	–	*	*	0	0
TAS	Test and Set an Operand	$(\text{Destination}) \text{ Tested} \rightarrow \text{CC}; 1 \rightarrow [7] \text{ of Destination}$	–	*	*	0	0
TRAP	Trap	$\text{PC} \rightarrow \text{SSP} @ -; \text{SR} \rightarrow \text{SSP} @ -; (\text{Vector}) \rightarrow \text{PC}$	–	–	–	–	–
TRAPV	Trap on Overflow	If V then TRAP	–	–	–	–	–
TST	Test and Operand	$(\text{Destination}) \text{ Tested} \rightarrow \text{CC}$	–	*	*	0	0
UNLK	Unlink	$\text{An} \rightarrow \text{SP}; \text{SP} @ + \rightarrow \text{An}$	–	–	–	–	–

Notes

- [] = bit number
- * = affected
- = unaffected
- 0 = cleared
- 1 = set
- U = defined
- @ = location addressed by

16-bit microcontroller

P90CE201

7.1 Addressing modes

Table 16 Data addressing modes.

MODE	GENERATION
Register Direct Addressing	
Data Register Direct	EA = D _n
Address Register Direct	EA = A _n
Absolute Data Addressing	
Absolute Short	EA = (Next Words)
Absolute Long	EA = (Next Two Words)
Program Counter Relative Addressing	
Relative with Offset	EA = (PC) + d ₁₆
Relative with Index and Offset	EA = (PC) + (X _n) + d ₈
Register Indirect Addressing	
Register Indirect	EA = (A _n)
Postincrement Register Indirect	EA = (A _n), A _n ← A _n + N
Predecrement Register Indirect	A _n ← A _n - N, EA = (A _n)
Register Indirect with Offset	EA = (A _n) + d ₁₆
Indexed Register Indirect with Offset	EA = (A _n) + (X _n) + d ₈
Immediate Data Addressing	
Immediate	DATA = Next Word(s)
Quick Immediate	Inherent Data
Implied Addressing	
Implied Register	EA = SR, USP, SSP, PC, SP

Notes

- EA = Effective Address
- A_n = Address Register
- D_n = Data Register
- X_n = Address or Data Register used as Index Register
- N = 1 for bytes; 2 for words; 4 for long words
- ← = Replaces
- SR = Status Register
- PC = Program Counter
- () = Contents of
- d₈ = 8-bit offset (displacement)
- d₁₆ = 16-bit offset (displacement)
- SP = Stack Pointer
- SSP = System Stack Pointer
- USP = User Stack Pointer

16-bit microcontroller

P90CE201

7.2 Instruction timing

This data assumes that both memory read and write cycle times are four internal clock periods (no additional wait states). Additional wait states for memory accesses have to be added to the total instruction time.

Accesses to registers listed in the Register Map are only three clock periods, therefore one clock period can be subtracted for each access to such a register. However, access to the UART registers takes up to ten clock periods due to synchronization. Consequently, ten clock periods have to be added for UART register accesses.

Table 17 Effective address calculation times.

SOURCE	ADDRESSING MODE	BYTE, WORD		LONG	
Rn	Data Address Register Direct	0	(0/0)	0	(0/0)
(An)	Address Register Indirect	4	(1/0)	8	(2/0)
(An)+	Address Register Indirect postincrement	4	(1/0)	8	(2/0)
-(An)	Address Register Indirect predecrement	7	(1/0)	11	(2/0)
d(An)	Address Register Indirect Displacement	11	(2/0)	15	(3/0)
d(An, Xi)	Address Register Indirect with Index	14	(2/0)	18	(3/0)
xxx.S	Absolute Short	8	(2/0)	12	(3/0)
xxx.L	Absolute Long	12	(3/0)	16	(4/0)
d(PC)	Program Counter with Displacement	11	(2/0)	15	(3/0)
d(PC, Xi)	Program Counter with Index	14	(2/0)	18	(3/0)
#xxx	Immediate	4	(1/0)	8	(2/0)

Note

1. The number of bus read and write cycles are shown in parentheses as (R/W).

Table 18 MOVE Byte and Move Word instruction clock periods.

SOURCE	Rn	(An)	(An)+	-(An)	d(An)	d(An,Xi)	xxx.S	xxx.L
Rn	7 (1/0)	11 (1/1)	11 (1/1)	14 (1/1)	18 (1/1)	21 (1/1)	15 (1/1)	19 (1/1)
(An)	11 (2/0)	15 (2/1)	15 (2/1)	18 (2/1)	22 (2/1)	25 (2/1)	19 (2/1)	23 (2/1)
(An)+	11 (2/0)	15 (2/1)	15 (2/1)	18 (2/1)	22 (2/1)	25 (2/1)	19 (2/1)	23 (2/1)
-(An)	14 (2/0)	18 (2/1)	18 (2/1)	22 (2/1)	25 (2/1)	28 (2/1)	22 (2/1)	26 (2/1)
d(An)	18 (3/0)	22 (3/1)	22 (3/1)	25 (3/1)	29 (3/1)	32 (3/1)	26 (3/1)	30 (3/1)
d(An,Xi)	21 (3/0)	25 (3/1)	25 (3/1)	28 (3/1)	32 (3/1)	35 (3/1)	29 (3/1)	33 (3/1)
xxx.S	15 (3/0)	19 (3/1)	19 (3/1)	22 (3/1)	26 (3/1)	29 (3/1)	23 (3/1)	27 (3/1)
xxx.L	19 (4/0)	23 (4/1)	23 (4/1)	26 (4/1)	30 (4/1)	33 (4/1)	27 (4/1)	31 (4/1)
d(PC)	18 (3/0)	22 (3/1)	22 (3/1)	25 (3/1)	29 (3/1)	32 (3/1)	26 (3/1)	30 (3/1)
d(PC,Xi)	21 (3/0)	25 (3/1)	25 (3/1)	28 (3/1)	32 (3/1)	35 (3/1)	29 (3/1)	33 (3/1)
#xxx	11 (2/0)	15 (2/1)	15 (2/1)	18 (2/1)	22 (2/1)	25 (2/1)	19 (2/1)	23 (2/1)

16-bit microcontroller

P90CE201

Table 19 MOVE Long instruction clock periods.

SOURCE	Rn	(An)	(An)+	-(An)	d(An)	d(An,Xi)	xxx.S	xxx.L
Rn	7 (1/0)	15 (1/2)	15 (1/2)	18 (1/2)	22 (2/2)	25 (2/2)	19 (2/2)	23 (3/2)
(An)	15 (3/0)	23 (3/2)	23 (3/2)	26 (3/2)	30 (4/2)	33 (4/2)	27 (4/2)	31 (5/2)
(An)+	15 (3/0)	23 (3/2)	23 (3/2)	26 (3/2)	30 (4/2)	33 (4/2)	27 (4/2)	31 (5/2)
-(An)	18 (3/0)	26 (3/2)	26 (3/2)	29 (3/2)	33 (4/2)	36 (4/2)	30 (4/2)	34 (5/2)
d(An)	22 (4/0)	30 (4/2)	30 (4/2)	33 (4/2)	37 (5/2)	40 (5/2)	34 (5/2)	38 (6/2)
d(An,Xi)	25 (4/0)	33 (4/2)	33 (4/2)	36 (4/2)	40 (5/2)	43 (5/2)	37 (5/2)	41 (6/2)
xxx.S	19 (4/0)	27 (4/2)	27 (4/2)	30 (4/2)	34 (5/2)	37 (5/2)	31 (5/2)	35 (6/2)
xxx.L	23 (5/0)	31 (5/2)	31 (5/2)	34 (5/2)	38 (6/2)	41 (6/2)	35 (6/2)	39 (7/2)
d(PC)	22 (4/0)	30 (4/2)	30 (4/2)	33 (4/2)	37 (5/2)	40 (5/2)	34 (5/2)	38 (6/2)
d(PC,Xi)	25 (4/0)	33 (4/2)	33 (4/2)	36 (4/2)	40 (5/2)	43 (5/2)	37 (5/2)	41 (6/2)
#xxx	15 (3/0)	23 (3/2)	23 (3/2)	26 (3/2)	30 (4/2)	33 (4/2)	27 (4/2)	31 (5/2)

Table 20 Standard instruction clock periods.

INSTR	SIZE	op < ea > ,An	op < ea > ,Dn	op < Dn > ,M
ADD	Byte, Word	7 + (1/0)	7 + (1/0)	11 + (1/1)
	Long	7 + (1/0)	7 + (1/0)	15 + (1/2)
AND	Byte, Word	–	7 + (1/0)	11 + (1/1)
	Long	–	7 + (1/0)	15 + (1/2)
CMP	Byte, Word	7 + (1/0)	7 + (1/0)	–
	Long	7 + (1/0)	7 + (1/0)	–
DIVS	–	–	169 + ** (1/0) ⁽³⁾	–
DIVU	–	–	130 + * (1/0) ⁽²⁾	–
EOR	Byte, Word	–	7 + (1/0)	11 + (1/1)
	Long	–	7 + (1/0)	15 + (1/2)
MULS	–	–	76 + * (1/0) ⁽²⁾	–
MULU	–	–	76 + * (1/0) ⁽²⁾	–
OR	Byte, Word	–	7 + (1/0)	11 + (1/1)
	Long	–	7 + (1/0)	15 + (1/2)
SUB	Byte, Word	7 + (1/0)	7 + (1/0)	11 + (1/1)
	Long	7 + (1/0)	7 + (1/0)	15 + (1/2)

Notes

1. + = add effective address calculation time
2. * = the duration of the instruction is constant
3. ** = indicates maximum value.

16-bit microcontroller

P90CE201

Table 21 Immediate instruction clock periods.

INSTR.	SIZE	op < # > ,Dn	op < # > ,An	op < # > ,< M >
ADDI	Byte, Word	14 (2/0)	–	18 + (2/1)
	Long	18 (3/0)	–	26 + (3/2)
ADDQ	Byte, Word	7 (1/0)	7 (1/0)	11 + (1/1)
	Long	7 (1/0)	7 (1/0)	15 + (1/2)
ANDI	Byte, Word	14 (2/0)	–	18 + (2/1)
	Long	18 (3/0)	–	24 + (3/2)
CMPI	Byte, Word	14 (2/0)	–	14 + (2/0)
	Long	18 (3/0)	–	18 + (3/0)
EORI	Byte, Word	14 (2/0)	–	18 + (2/1)
	Long	18 (3/0)	–	26 + (3/2)
MOVEQ	Long	7 (1/0)	–	–
ORI	Byte, Word	14 (2/0)	–	18 + (2/1)
	Long	18 (3/0)	–	26 + (3/2)
SUBI	Byte, Word	14 (2/0)	–	18 + (2/1)
	Long	18 (3/0)	–	26 + (3/2)
SUBQ	Byte, Word	7 (1/0)	7 (1/0)	11 + (1/1)
	Long	7 (1/0)	7 (1/0)	15 + (1/2)

Note

1. += add effective calculation time.

16-bit microcontroller

P90CE201

Table 22 Single operand instruction clock periods.

INSTRUCTION	SIZE	REGISTER	MEMORY
CLR	Byte, Word	7 (1/0)	11 (1/1)+ * (2)
	Long	7 (1/0)	15 (1/2)+ ** (3)
NBCD	Byte	10 (1/0)	14 (1/1)(2)
NEG	Byte, Word	7 (1/0)	11 (1/1)+
	Long	7 (1/0)	15 (1/2)+
NEGX	Byte, Word	7 (1/0)	11 (1/1)+
	Long	7 (1/0)	15 (1/2)+
NOT	Byte, Word	7 (1/0)	11 (1/1)+
	Long	7 (1/0)	15 (1/2)+
Scc	Byte, Word	13 (1/0)	17 (1/1)+
	Long	13 (1/0)	14 (1/1)+
TAS	Byte, Word	10 (1/0)	15 (2/1)+ * (2)
TST	Byte, Word	7 (1/0)	7 (1/0)+
	Long	7 (1/0)	7 (1/0)+

Notes

1. += add effective calculation time
2. * = subtract one read cycle ($-4(1/0)$) from effective address calculation
3. ** = subtract two read cycles ($-8(2/0)$) from effective address calculation.

Table 23 Shift/rotate instruction clock periods.

INSTRUCTION	SIZE	REGISTER	MEMORY
ASR,ASL	Byte, Word	$13 + 3n$ (1/0)	14 (1/1)+
	Long	$13 + 3n$ (1/0)	–
LSR,LSL	Byte, Word	$13 + 3n$ (1/0)	14 (1/1)+
	Long	$13 + 3n$ (1/0)	–
ROR,ROL	Byte, Word	$13 + 3n$ (1/0)	14 (1/1)+
	Long	$13 + 3n$ (1/0)	–
ROXR,ROXL	Byte, Word	$13 + 3n$ (1/0)	14 (1/1)+
	Long	$13 + 3n$ (1/0)	–

Note

1. += add effective calculation time.

16-bit microcontroller

P90CE201

Table 24 Bit manipulation instruction clock periods.

INSTRUCTION	SIZE	DYNAMIC		STATIC	
		REGISTER	MEMORY	REGISTER	MEMORY
BCHG	Byte	–	14 (1/1)+	–	21 (2/1)+
	Long	10 (1/0)	–	17 (2/0)	–
BCLR	Byte	–	14 (1/1)+	–	21 (2/1)+
	Long	10 (1/0)	–	17 (2/0)	–
BSET	Byte	–	14 (1/1)+	–	21 (2/1)+
	Long	10 (1/0)	–	17 (2/0)	–
BTST	Byte	–	7 (1/0)+	–	14 (2/0)+
	Long	7 (1/0)	–	14 (2/0)	–

Note

1. += add effective calculation time.

Table 25 Conditional instruction clock periods.

INSTRUCTION	DISPLACEMENT	TRAP/BRANCH TAKEN	TRAP/BRANCH NOT TAKEN
Bcc	.B	13 (1/0)	13 (1/0)
	.W	14 (2/0)	14 (2/0)
BRA	.B	13 (1/0)	–
	.W	14 (2/0)	–
BSR	.B	21 (1/2)	–
	.W	25 (2/2)	–
DBcc	cc True	–	14 (2/0)
	cc False	17 (2/0)	17 (3/2)
CHK	–	70 (3/4)	19 (1/0)+
TRAPV	–	55 (3/4)	10 (1/0)

Note

1. += add effective calculation time.

16-bit microcontroller

P90CE201

Table 26 JMP, JSR, LEA, PEA, MOVEM instruction clock periods.

INSTR	Size	(An)	(An)+	-(An)	d(An)	d(An, Xi)	xxx.S	xxx.L	d(PC)	d(PC,Xi)
JMP	–	7	–	–	14	17	14	18	14	17
	–	(1/0)	–	–	(2/0)	(2/0)	(2/0)	(3/0)	(2/0)	(2/0)
JSR	–	18	–	–	25	28	25	29	25	28
	–	(1/2)	–	–	(2/2)	(2/2)	(2/2)	(3/2)	(2/2)	(2/2)
LEA	–	7	–	–	14	17	14	18	14	17
	–	(1/0)	–	–	(2/0)	(2/0)	(2/0)	(3/0)	(2/0)	(2/0)
PEA	–	18	–	–	25	28	25	29	25	28
	–	(1/2)	–	–	(2/2)	(2/2)	(2/2)	(3/2)	(2/2)	(2/2)
MOVEM M → R	.W	26 + 7n (2+n/0)	26 + 7n (2+n/0)	–	30 + 7n (3+n/0)	33 + 7n (3+n/0)	30 + 7n (3+n/0)	34 + 7n (4+n/0)	30 + 7n (3+n/0)	33 + 7n (3+n/0)
	.L	26 + 11n (2+2n/0)	26 + 11n (2+2n/0)	–	30 + 11n (3+2n/0)	33 + 11n (3+2n/0)	30 + 11n (3+2n/0)	34 + 11n (4+2n/0)	30 + 11n (3+2n/0)	33 + 11n (3+2n/0)
MOVEM R → M	.W	23 + 7n (2/n)	–	23 + 7n (2/n)	27 + 7n (3/n)	30 + 7n (3/n)	27 + 7n (3/n)	31 + 7n (4/n)	–	–
	.L	23 + 11n (2/2N)	–	23 + 11n (2/2n)	27 + 11n (3/2n)	30 + 11n (3/2n)	27 + 11n (3/2n)	31 + 11n (4/2n)	–	–

Note

1. n = number of registers to move.

Table 27 Multi-precision instruction clock periods.

INSTRUCTION	SIZE	op Dn, Dn	op M, M
ADDX	Byte, Word	7 (1/0)	28 (3/1)
	Long	7 (1/0)	40 (5/2)
CMPM	Byte, Word	–	18 (3/0)
	Long	–	26 (5/0)
SUBX	Byte, Word	7 (1/0)	28 (3/1)
	Long	7 (1/0)	40 (5/2)
ABCD	Byte	10 (1/0)	31 (3/1)
SBCD	Byte	10 (1/0)	31 (3/1)

16-bit microcontroller

P90CE201

Table 28 Miscellaneous clock periods.

INSTRUCTION	SIZE	REGISTER	MEMORY	REGISTER to MEMORY	MEMORY to REGISTER
ANDI to CCR	–	14 (2/0)	–	–	–
ANDI to SR	–	14 (2/0)	–	–	–
EORI to CCR	–	14 (2/0)	–	–	–
EORI to SR	–	14 (2/0)	–	–	–
EXG	–	13 (1/0)	–	–	–
EXT	WORD	7 (1/0)	–	–	–
	LONG	7 (1/0)	–	–	–
LINK	–	25 (2/2)	–	–	–
MOVE from SR	–	7 (1/0)	11 (1/1)+	–	–
MOVE to CCR	–	10 (1/0)	10 (1/0)+	–	–
MOVE to SR	–	10 (1/0)	10 (1/0)+	–	–
MOVE from USP	–	7 (1/0)	–	–	–
MOVE to USP	–	7 (1/0)	–	–	–
MOVEP	WORD	–	–	25 (2/2)	22 (4/0)
	LONG	–	–	39 (2/4)	36 (6/0)
NOP	–	7 (1/0)	–	–	–
ORI to CCR	–	14 (2/0)	–	–	–
ORI to SR	–	14 (2/0)	–	–	–
RESET	–	154 (1/0)	–	–	–
RTE - short format	–	39 (5/0)	–	–	–
RTE - long format	–	–	–	–	–
no rerun	–	140 (18/0)	–	–	–
with rerun	–	146 (18/0)	–	–	–
return of TAS	–	151 (19/0)	–	–	–
RTR	–	22 (4/0)	–	–	–
RTS	–	15 (3/0)	–	–	–
STOP	–	17 (2/0)	–	–	–
SWAP	–	7 (1/0)	–	–	–
UNLK	–	15 (3/0)	–	–	–

Note

1. += add effective address calculation time.

16-bit microcontroller

P90CE201

Table 29 Exception processing clock periods.

EXCEPTION	NUMBER OF CLOCK PERIODS
Address error	158 (3/17)
Interrupt	65 (4/4), note 1
Illegal instruction	55 (3/4)
Privilege instruction	55 (3/4)
Trace	55 (3/4)
Trap	52 (3/4)
Divide by Zero	64 (3/4)+
RESET (note 2)	43 (4/0)

Note

1. The interrupt acknowledge bus cycle is assumed to take four clock periods.
2. The maximum time from when RESET is first sampled as released to first instruction fetch.

16-bit microcontroller

P90CE201

8 I²C-BUS INTERFACE

8.1 General

The P90CE201 contains two fully independent I²C-bus serial interfaces (I²C1 and I²C2); the functionality of both is identical. The I²C-bus interfaces can operate in four modes:

1. Master transmitter
2. Master receiver
3. Slave transmitter
4. Slave receiver.

The I²C-bus interface is connected to the I²C-bus by a data pin (SDA) and by a clock pin (SCL). Data transport, clock generation, address recognition and bus arbitration are all controlled by hardware. Each I²C-bus interface is controlled by a set of six registers.

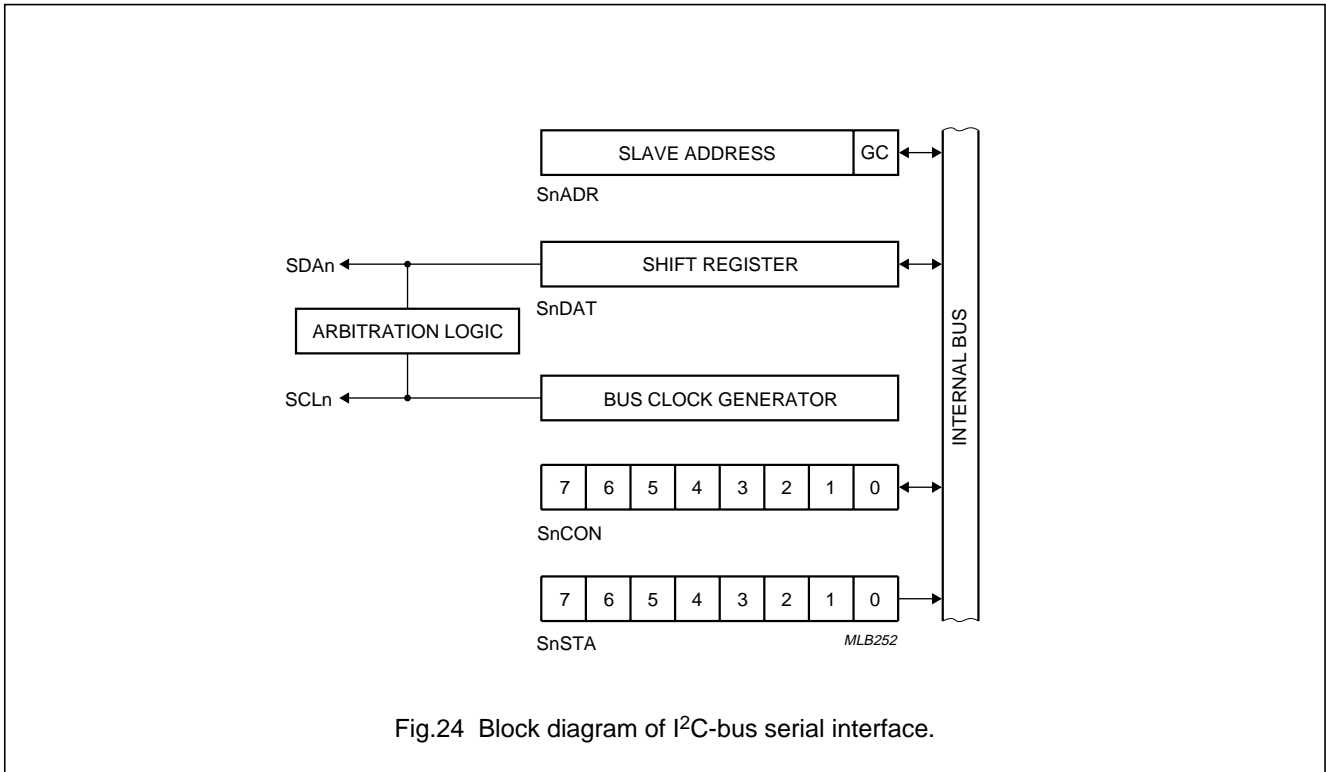

Fig.24 Block diagram of I²C-bus serial interface.

16-bit microcontroller

P90CE201

8.2 I²C-bus interface registers

In the following register descriptions “n” represents the I²C-bus serial interface number (1 or 2); its associated registers are identified using the same number.

8.2.1 SERIAL CONTROL REGISTER (SnCON)

S1CON is located at address 8000 2007H; S2CON is located at address 8000 2017H. These registers have a default value of 00H.

bit 7	bit 6	bit 5	bit 4	bit 3	bit 2	bit 1	bit 0
CR2	ENS	STA	STO	SI	AA	CR1	CR0

Fig.25 Serial Control Register (SnCON)

Table 30 Description of SnCON bits.

SYMBOL	BIT	FUNCTION
CR2 CR1 CR0	SnCON.7 SnCON.1 SnCON.0	Clock Rate. These three bits along with bit SYSCON2.12 (or SYSCON2.11) determine the serial clock frequency that is generated in the master mode of operation. The frequencies of 100 kHz and 400 kHz can be selected for the oscillators frequencies of 12, 16, 20 and 24 MHz, as shown in Table 31.
ENS	SnCON.6	Enable Serial I/O. When ENS = 0; the serial interface I/O is disabled and reset. When ENS = 1; the serial interface is enabled.
STA	SnCON.5	Start flag. When this bit is set in slave mode, the hardware checks the I ² C-bus and generates a START condition if the bus is free or after the bus becomes free. If the device operates in Master Mode it will generate a repeated START condition.
STO	SnCON.4	Stop flag. If this bit is set in the master mode a STOP condition is generated. A STOP condition detected on the I ² C-bus clears this bit. The STOP bit may also be set in Slave Mode in order to recover from an error condition. In this case no STOP condition is generated to the I ² C-bus, but the hardware releases the SDA and SCL lines and switches to the not selected slave receiver mode. The STOP flag is cleared by the hardware.
SI	SnCON.3	Serial Interrupt flag. This flag is set, and an interrupt is generated, after any of the following events occur: <ul style="list-style-type: none"> - A START condition is generated in Master Mode - The own slave address has been received during AA = 1 - The general call address has been received while SnADR.0 = 1 and AA = 1 - A data byte has been received or transmitted in master mode - A data byte has been received or transmitted as selected slave - A STOP or START condition is received as selected slave receiver or transmitter. While the SI flag is set, SCL remains LOW and the serial transfer is suspended. SI must be reset by software.

16-bit microcontroller

P90CE201

SYMBOL	BIT	FUNCTION
AA	SnCON.2	Assert Acknowledge. When this bit is set, an acknowledge is returned after any one of the following conditions: <ul style="list-style-type: none"> - Own slave address is received - The general call address is received (S1ADR.0 = 1) - A data byte is received, while the device is programmed to be a master receiver - A data byte is received, while the device is a selected slave receiver. When this bit is reset, no acknowledge is returned. Consequently, no interrupt is requested when the own slave address or general call address is received.

Table 31 Selection of I²C-bus bit rate.

CR3 (note 1)	CR2	CR1	CR0	BIT RATE at f _{CLK} (MHz)				UNIT	DEVICE
				12	16	20	24		
0	0	0	0	200	266.66	333.33	400	kHz	Fast I ² C-bus
0	0	0	1	240	320	400	–	kHz	
0	0	1	0	300	400	–	–	kHz	
0	0	1	1	400	–	–	–	kHz	
0	1	0	0	50	66.67	83.33	100	kHz	Standard I ² C-bus
0	1	0	1	60	80	100	–	kHz	
0	1	1	0	75	100	–	–	kHz	
0	1	1	1	100	–	–	–	kHz	
1	0	0	0	6.25	8.33	10.42	12.5	kHz	
1	0	0	1	7.5	10	12.5	15	kHz	
1	0	1	0	9.38	12.5	15.63	18.75	kHz	
1	0	1	1	12.5	16.67	20.83	25	kHz	
1	1	0	0	3.13	4.17	5.21	6.25	kHz	
1	1	0	1	3.75	5	6.25	7.5	kHz	
1	1	1	0	4.69	6.25	7.81	9.38	kHz	
1	1	1	1	6.25	8.33	10.42	12.5	kHz	

Note

1. CR3 is defined by SYSCON2.12 (or SYSCON2.11).

16-bit microcontroller

P90CE201

8.2.2 SERIAL STATUS REGISTER (SnSTA)

S1STA resides at address 8000 2005H; S2STA resides at address 8000 2015H. The contents of the Serial Status Registers may be used as vectors to service routines. This optimizes the response time of the software and consequently that of the I²C-bus. S1STA and S2STA are read-only registers. These registers have a default value of F8H.

bit 7	bit 6	bit 5	bit 4	bit 3	bit 2	bit 1	bit 0
SC4	SC3	SC2	SC1	SC0	0	0	0

Fig.26 Serial Status Register (SnSTA).

Table 32 Description of SnSTA bits.

SYMBOL	BIT	FUNCTION
SC4	SnSTA.7	Status Code. These 5 bits may be read in order to determine the status of the I ² C-bus. Tables 33 to 37 show all the status codes.
SC3	SnSTA.6	
SC2	SnSTA.5	
SC1	SnSTA.4	
SC0	SnSTA.3	
–	S1STA.2	These three bits are held LOW and allow the user to use the status code directly as a vector to a service routine.
–	S1STA.1	
–	S1STA.0	

Table 33 Master Transmitter Mode.

S1STA VALUE	DESCRIPTION
08H	A START condition has been transmitted
10H	A repeated START condition has been transmitted
18H	SLA and W have been transmitted, ACK has been received
20H	SLA and W have been transmitted, $\overline{\text{ACK}}$ received
28H	DATA of SnDAT has been transmitted, ACK received
30H	DATA of SnDAT has been transmitted, $\overline{\text{ACK}}$ received
38H	Arbitration lost in SLA, R/W or DATA

Table 34 Master Receiver Mode.

S1STA VALUE	DESCRIPTION
08H	A START condition has been transmitted
10H	A repeated START condition has been transmitted
38H	Arbitration lost while returning $\overline{\text{ACK}}$
40H	SLA and R have been transmitted, ACK received
48H	SLA and R have been transmitted, $\overline{\text{ACK}}$ received
50H	DATA has been received, ACK returned
58H	DATA has been received, $\overline{\text{ACK}}$ returned

16-bit microcontroller

P90CE201

Table 35 Slave Receiver Mode.

S1STA VALUE	DESCRIPTION
60H	Own SLA and W have been received, ACK returned
68H	Arbitration lost in SLA, R/W as MST. Own SLA and W have been received, ACK returned
70H	General call has been received, ACK returned
78H	Arbitration lost in SLA, R/W as MST. General call received, ACK returned
80H	Previously addressed with own SLA. DATA byte received, ACK returned
88H	Previously addressed with own SLA. DATA byte received, $\overline{\text{ACK}}$ returned
90H	Previously addressed with general call. DATA byte received, ACK has been returned
98H	Previously addressed with general call. DATA byte received, $\overline{\text{ACK}}$ has been returned
A0H	A STOP condition or repeated START condition received while still addressed as SLV/REC or SLV/TRX

Table 36 Slave Transmitter Mode.

S1STA VALUE	DESCRIPTION
A8H	Own SLA and R received, ACK returned
B0H	Arbitration lost in SLA, R/W as MST. Own SLA and R received, ACK returned
B8H	DATA byte has been transmitted, ACK received
C0H	DATA byte has been transmitted, $\overline{\text{ACK}}$ received
C8H	Last DATA byte has been transmitted, ACK received

Table 37 Miscellaneous.

S1STA VALUE	DESCRIPTION
00H	Bus error during MST mode or selected SLV mode, due to an erroneous START or STOP condition
F8H	No relevant information available, SI not set

ABBREVIATIONS USED:

SLA:	7-bit slave address
R:	Read bit
W:	Write bit
ACK:	Acknowledgement (acknowledge bit = logic 0)
$\overline{\text{ACK}}$:	No acknowledgement (acknowledge bit = logic 1)
DATA:	8-bit data byte to or from I ² C-bus
MST:	Master
SLV:	Slave
TRX:	Transmitter
REC:	Receiver.

16-bit microcontroller

P90CE201

8.2.3 DATA SHIFT REGISTER (SnDAT)

S1DAT is located at address 8000 2001H; S2DAT is located at address 8000 2011H. These two identical registers contain the serial data to be transmitted or data that has just been received. Bit 7 is transmitted or received first; i.e. data shifted from right to left. These registers have a default value of 00H.

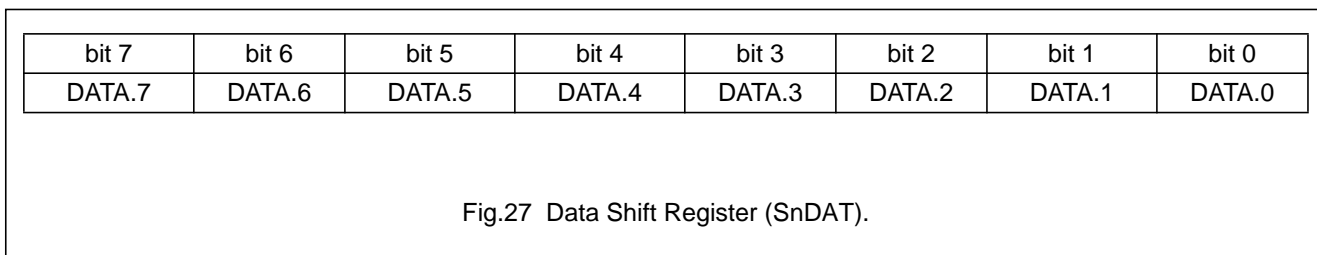

8.2.4 ADDRESS REGISTER (SnADR)

S1ADR resides at address 8000 2003H; S2ADR resides at address 8000 2013H. These two identical 8-bit registers may be loaded with the 7-bit slave address to which the controller will respond when programmed as a slave receiver/transmitter. The LSB (GC) is used to determine whether the general call address is recognized. These registers have a default value of 00H.

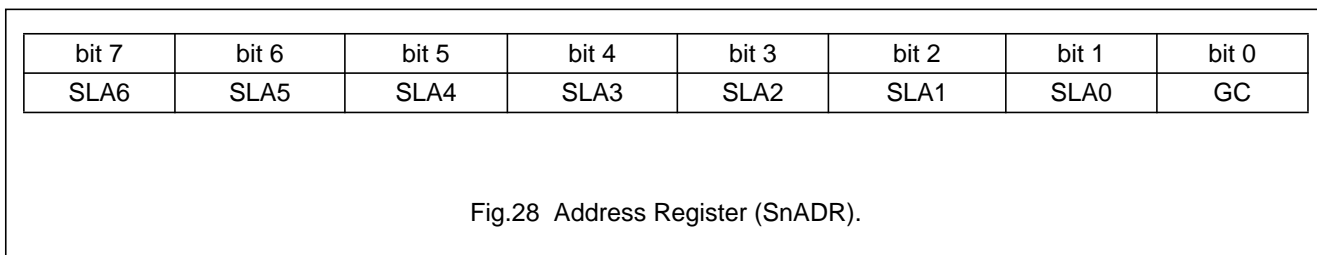

Table 38 Description of SnADR bits.

SYMBOL	BIT	FUNCTION
SLA6 to SLA0	SnADR.7 to SnADR.1	Own slave address
GC	SnADR.0	When a logic 0, the general call address is not recognized. When a logic 1, the general call address is recognized

16-bit microcontroller

P90CE201

8.2.5 INTERRUPT REGISTERS

The I²C-bus interface contains four registers for the control of I²C-bus interrupts. One pair of registers (S1IR and S1IV) provide independent control of the I²C1 interface interrupts; the other pair of registers (S2IR and S2IV) provide independent control of the I²C2 interface interrupts.

In the following register descriptions “n” represents the I²C-bus interface number (1 or 2), its associated registers are identified using the same number.

8.2.6 INTERRUPT REGISTERS (SnIR)

These registers have a default value of XX0X0000_b.

bit 7	bit 6	bit 5	bit 4	bit 3	bit 2	bit 1	bit 0
–	–	AVN	–	PIR	IPL2	IPL1	IPL0

Fig.29 Interrupt Register (SnIR).

Table 39 Description of SnIR bits.

SYMBOL	BIT	FUNCTION
–	SnIR.7	Reserved
–	SnIR.6	Reserved
AVN	SnIR.5	Autovector. When AVN = 0; the interrupt is an autovector interrupt and the processor calculates the appropriate vector from a fixed vector table. AVN = 0 is also the default value. When AVN = 1; the interrupt is a vectored interrupt and the peripheral must provide an 8-bit vector number.
–	SnIR.4	Reserved
PIR	SnIR.3	Pending Interrupt Request. This bit is set to a logic 1 when a valid interrupt request has been detected. It is automatically reset by the interrupt acknowledge cycle from the CPU. If PIR = 0, there is no pending interrupt request; this is also the default value. The PIR bit can also be reset by software by writing a logic 0 to this location.
IPL2 IPL1 IPL0	SnIR.2 SnIR.1 SnIR.1	Interrupt Priority Level. These three bits select the interrupt priority level. See Table 40.

Table 40 Selection of interrupt priority level.

IPL2	IPL1	IPL0	PRIORITY LEVEL
0	0	0	Interrupt inhibited; this is also the default value.
0	0	1	Level 1
0	1	0	Level 2
0	1	1	Level 3
1	0	0	Level 4
1	0	1	Level 5
1	1	0	Level 6
1	1	1	Level 7

16-bit microcontroller

P90CE201

8.2.7 INTERRUPT VECTOR (SnIV)

These registers have a default value of 0FH.

bit 7	bit 6	bit 5	bit 4	bit 3	bit 2	bit 1	bit 0
IV.7	IV.6	IV.5	IV.4	IV.3	IV.2	IV.1	IV.0

Fig.30 Interrupt Vector (SnIV).

Table 41 Description of SnIV bits.

SYMBOL	BIT	FUNCTION
IV.7 to IV.0	SnIV.7 to SnIV.0	8-bit interrupt vector number. The default value of this register is 0FH.

16-bit microcontroller

P90CE201

9 UART SERIAL INTERFACE

9.1 General

This serial port is full duplex which means that it can transmit and receive simultaneously. It is also receive-buffered and can commence reception of a second byte before a previously received byte has been read from the receive register. (However, if the first byte has not been read by the time the reception of the second byte is complete, one of the bytes will be lost). The serial port receive and transmit registers are both accessed as register SBUF. Writing to SBUF loads the Transmit Register and reading SBUF accesses the physically separate Receive Register. The baud rate for receiver and transmitter can be generated by any timer using its baud rate generator output.

Mode 2: 11 bits are transmitted (through TXD) or received (through RXD): a start bit (0), 8 data bits (LSB first), a programmable 9th data bit, and a stop bit (1). On transmit, the 9th data bit (TB8 in SCON) usually represents the parity bit. On receive, the 9th data bit is stored in RB8 in SCON, while the stop bit is ignored. The baud rate is fixed at 3/32 of the BPCLK frequency.

Mode 3: 11 bits are transmitted (through TXD) or received (through RXD): a start bit (0), 8 data bits (LSB first), a programmable 9th data bit and a stop bit (1). Mode 3 is the same as Mode 2 except that the baud rate in Mode 3 is variable.

9.2 Operating modes

The serial port can operate in one of four modes:

Mode 0: Serial data enters and exits through RXD. TXD outputs the shift clock. 8 data bits are transmitted or received (LSB first). The baud rate is fixed at 1/4 the basic peripheral clock.

Mode 1: 10 bits are transmitted (through TXD) or received (through RXD): a start bit (0), 8 data bits (LSB first), and a stop bit (1). On receive, the stop bit is stored in RB8 in register SCON. The baud rate is variable.

In all four modes, transmission is initiated by any instruction that uses SBUF as a destination register. Reception is initiated in Mode 0 by the condition RI = 0 and REN = 1. Reception is initiated in the other modes by the incoming start bit if REN = 1.

9.3 UART registers

9.3.1 UART SHIFT REGISTER (SBUF)

The UART Shift Register resides at address 8000 2021H. SBUF contains the serial data to be transmitted or data just being received. Bit 0 is transmitted or received first; i.e data is shifted from left to right.

bit 7	bit 6	bit 5	bit 4	bit 3	bit 2	bit 1	bit 0
SBUF.7	SBUF.6	SBUF.5	SBUF.4	SBUF.3	SBUF.2	SBUF.1	SBUF.0

Fig.31 UART Shift Register (SBUF).

16-bit microcontroller

P90CE201

9.3.2 UART CONTROL REGISTER (SCON)

The Serial Port Control Register and Status Register (SCON) contains not only the mode selection bits, but also the 9th data bit for transmit and receive (TB8 and RB8), and the serial port interrupt bits (TI and RI). SCON has a default value of 00H.

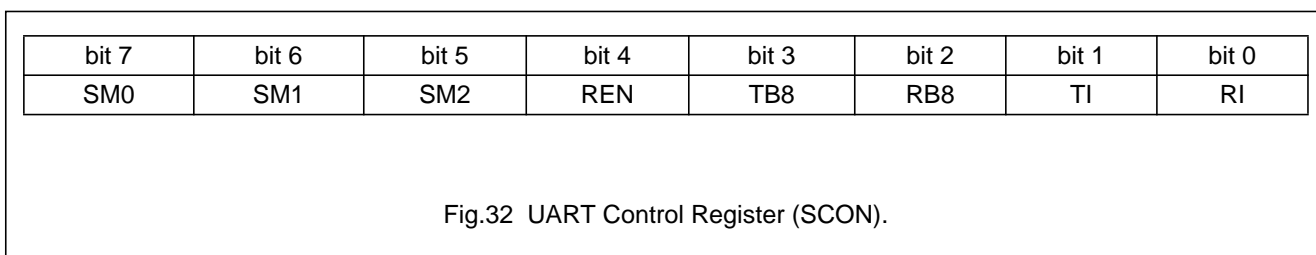

Table 42 Description of SCON bits.

SYMBOL	BIT	FUNCTION
SM0 SM1	SCON.7 SCON.6	These two bits are used to select the serial port mode. See Table 43.
SM2	SCON.5	Enables the multiprocessor communication feature in Modes 2 and 3. In Modes 2 and 3, if SM2 = 1, then RI will not be activated if the received 9th data bit (RB8) is a logic 0. In Mode 1, if SM2 = 1, then RI will not be activated unless a valid stop bit was received. In Mode 0, SM2 should be a logic 0.
REN	SCON.4	Enables serial reception and is set by software to enable reception, and cleared by software to disable reception.
TB8	SCON.3	The 9th data bit that will be transmitted in Modes 2 and 3. Set or cleared by software as required.
RB8	SCON.2	In Modes 2 and 3, RB8 is the 9th data bit that is received. In Mode 1, if SM2 = 0, then RB8 is the stop bit that was received. In Mode 0, RB8 is not used.
TI	SCON.1	Transmit Interrupt flag. Set by hardware at the end of the 8th bit time in Mode 0, or at the beginning of the stop bit time in the other modes, in any serial transmission. Must be cleared by software.
RI	SCON.0	Receive Interrupt flag. Set by hardware at the end of the 8th bit time in Mode 0, or halfway through the stop bit time in the other modes, in any serial transmission (however see SM2). Must be cleared by software.

Table 43 Selection of the serial port modes.

SM0	SM1	MODE	DESCRIPTION	BAUD RATE
0	0	0	Shift register	BPCLK/4
0	1	1	8-bit UART	variable
1	0	2	9-bit UART	3/32 BPCLK
1	1	3	9-bit UART	variable

16-bit microcontroller

P90CE201

9.3.3 UART INTERRUPT REGISTERS

The UART interface contains four registers for the control of the transmitter and receiver interrupts. One pair of registers (UTIR and UTIV) provide independent control of transmitter interrupts; the other pair of registers (URIR and URIV) provide independent control of receiver interrupts.

In the following register descriptions “x” can be replaced by “T” for transmitter, or “R” for receiver.

9.3.4 UART TRANSMITTER/RECEIVER INTERRUPT REGISTER (UXIR)

These registers have a default value of $XX0X0000_b$.

bit 7	bit 6	bit 5	bit 4	bit 3	bit 2	bit 1	bit 0
–	–	AVN	–	PIR	IPL2	IPL1	IPL0

Fig.33 UART Transmitter/Receiver Interrupt Register (UxIR).

Table 44 Description of UxIR bits.

SYMBOL	BIT	FUNCTION
–	UxIR.7	Reserved
–	UxIR.6	Reserved
AVN	UxIR.5	Autovector. When AVN = 0; the transmitter/receiver interrupt is an autovector interrupt and the processor calculates the appropriate vector from a fixed vector table. AVN = 0 is also the default value. When AVN = 1; the transmitter/receiver interrupt is a vectored interrupt and the peripheral must provide an 8-bit vector number.
–	UxIR.4	Reserved
PIR	UxIR.3	Pending Interrupt Request. This bit is set to a logic 1 when a valid interrupt request has been detected. It is automatically reset by the interrupt acknowledge cycle from the CPU. If PIR = 0; there is no pending interrupt request; this is also the default value. PIR can be reset by software by writing a logic 0 to this location.
IPL2 IPL1 IPL0	UxIR.2 UxIR.1 UXIR.0	Interrupt Priority Level. These three bits determine the interrupt priority level of the interrupt requested by the transmitter/receiver. See Table 45.

16-bit microcontroller

P90CE201

Table 45 Selection of transmitter/receiver interrupt priority level.

IPL2	IPL1	IPL0	PRIORITY LEVEL
0	0	0	Interrupt inhibited; this is also the default value.
0	0	1	Level 1
0	1	0	Level 2
0	1	1	Level 3
1	0	0	Level 4
1	0	1	Level 5
1	1	0	Level 6
1	1	1	Level 7

9.3.5 UART TRANSMITTER/RECEIVER INTERRUPT VECTOR (UXIV)

These registers have a default value of 0FH.

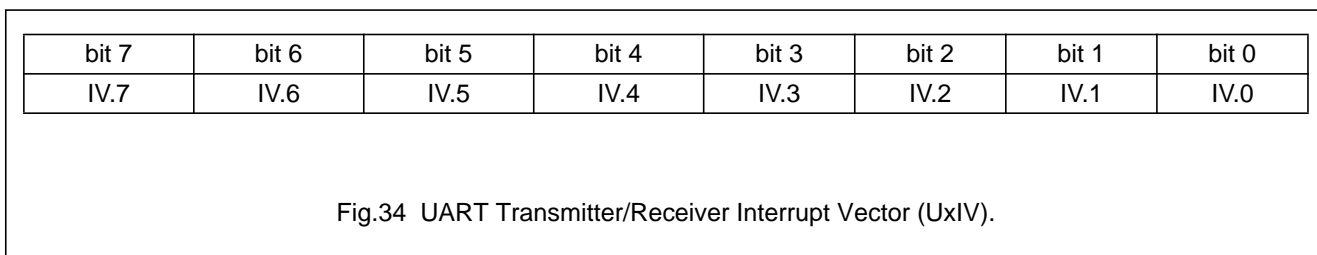

Table 46 Description of UxIV bits.

SYMBOL	BIT	FUNCTION
IV.7 to IV.0	UTIV.7 to UTIV.0	8-bit interrupt vector number. The default value of this register is 0FH.

16-bit microcontroller

P90CE201

10 8-BIT GENERAL PORT

The port is configured as a quasi-bidirectional port. A port pin is set to input mode by writing a logic 1 to the corresponding General Port Register (GP) bit. This drives a “hard” logic 1 to the corresponding output pin for a short period. After this period the logic 1 level is maintained by a weak pull-up transistor, which can be overwritten by an external signal.

A read from GP reads the value from the corresponding General Port Register bit. A read from the General Port Pad/Register (GPP) reads the value from the corresponding port input pin. A write to either GP or GPP writes the value to the port register (GP) from where it is driven to the corresponding port pins. After RESET the port is set to input mode. Bits 0 to 3 can be used as high current drive outputs at a logic 0. Bits 6 and 7 may also be used for I²C1 and therefore no internal pull-ups are implemented.

10.1 8-bit General Port registers

10.1.1 GENERAL PORT REGISTER (GP)

This register is located at address 8000 2073H.

bit 7	bit 6	bit 5	bit 4	bit 3	bit 2	bit 1	bit 0
GP7	GP6	GP5	GP4	GP3	GP2	GP1	GP0

Fig.35 General Port Register (GP).

10.1.2 GENERAL PORT PAD/REGISTER (GPP)

This register is located at address 8000 2071H.

bit 7	bit 6	bit 5	bit 4	bit 3	bit 2	bit 1	bit 0
GPP7	GPP6	GPP5	GPP4	GPP3	GPP2	GPP1	GPP0

Fig.36 General Port Pad/Register (GPP).

16-bit microcontroller

P90CE201

11 8-bit AUXILIARY PORT

Unused address pins can be used as auxiliary ports. The selection of unused address pins (A23 to A16) for use as auxiliary ports is controlled by the Auxiliary Port Control Register (APCON).

Each bit in APCON controls one address pin. A logic 1 written to APCON.n enables the auxiliary port function of the address pin A(n + 16). The APCON bits and their associated address pins are shown in Fig.37. A logic 0 written to APCON.n disables the auxiliary port function and drives the internal address bus to A(n + 16).

If bit APCON.n is set, a read from the corresponding bit APP.n in the Auxiliary Port Pad/Register (APP), reads the value from the address pin A(n + 16). A write to APP.n when APCON.n is set, drives the value of APP.n to the address pin A(n + 16). After RESET the auxiliary port function is disabled (APCON = 00H).

The Auxiliary Port is configured as a quasi-bidirectional port in the same way as described for the 8-bit General Port. A port pin is set to input mode by writing a logic 1 to the corresponding port register bit. This drives a "hard" logic 1 to the corresponding output pin for a short period. After this period the logic 1 level is maintained by a weak pull-up transistor, which can be overwritten by an external signal.

11.1 8-bit Auxiliary Port registers**11.1.1 AUXILIARY PORT CONTROL REGISTER (APCON)**

This register is located at address 8000 2083H.

bit 7	bit 6	bit 5	bit 4	bit 3	bit 2	bit 1	bit 0
APCON.7 (A23)	APCON.6 (A22)	APCON.5 (A21)	APCON.4 (A20)	APCON.3 (A19)	APCON.2 (A18)	APCON.1 (A17)	APCON.0 (A16)

Fig.37 Auxiliary Port Control Register (APCON).

11.1.2 AUXILIARY PORT PAD/REGISTER (APP)

This register is located at address 8000 2081H.

bit 7	bit 6	bit 5	bit 4	bit 3	bit 2	bit 1	bit 0
APP7	APP6	APP5	APP4	APP3	APP2	APP1	APP0

Fig.38 Auxiliary Port/Pad Register (APP).

16-bit microcontroller

P90CE201

12 WATCHDOG TIMER

The P90CE201 contains a Watchdog Timer. Its purpose is to reset the microcontroller, after a programmable time interval, in the event of the microcontroller entering an erroneous processor state. Erroneous processor states can be caused by noise or RFI.

The Watchdog Timer consists of a 14-bit prescaler and an 8-bit timer (WDTIM). The prescaler is incremented by the basic peripheral clock. WDTIM is incremented every 16384 cycles of the basic peripheral clock. It is the value written to WDTIM that determines the Watchdog Timer interval. If the timer interval is exceeded, the Watchdog Timer overflows and the microcontroller is reset. In order to prevent a timer overflow, the user program must reload the Watchdog Timer within a time period shorter than the programmed Watchdog Timer interval.

The Watchdog Timer is controlled by the Watchdog Control Register (WDCON). WDCON can be read and

written to by software. After RESET, the Watchdog Timer is disabled and WDCON contains A5H which clears both the prescaler and WDTIM. The Watchdog Timer is enabled by the first write operation to WDCON after RESET. A running Watchdog Timer can only be disabled by resetting the device.

WDTIM can be read on the fly but can only be written to if WDCON has been loaded with 5AH. A successful write operation to WDTIM also clears the prescaler and sets WDCON to 00H in order to prevent further, unintentional, write operations to WDTIM.

The Watchdog Timer interval (t) may be calculated as follows:

$$t = \frac{(256 - \text{WDTIM value}) \times 16384}{\text{basic peripheral clock frequency}}$$

For example, if the basic peripheral clock frequency is 4 MHz, the Watchdog Timer interval will be within the range 4.1 ms to 1 second.

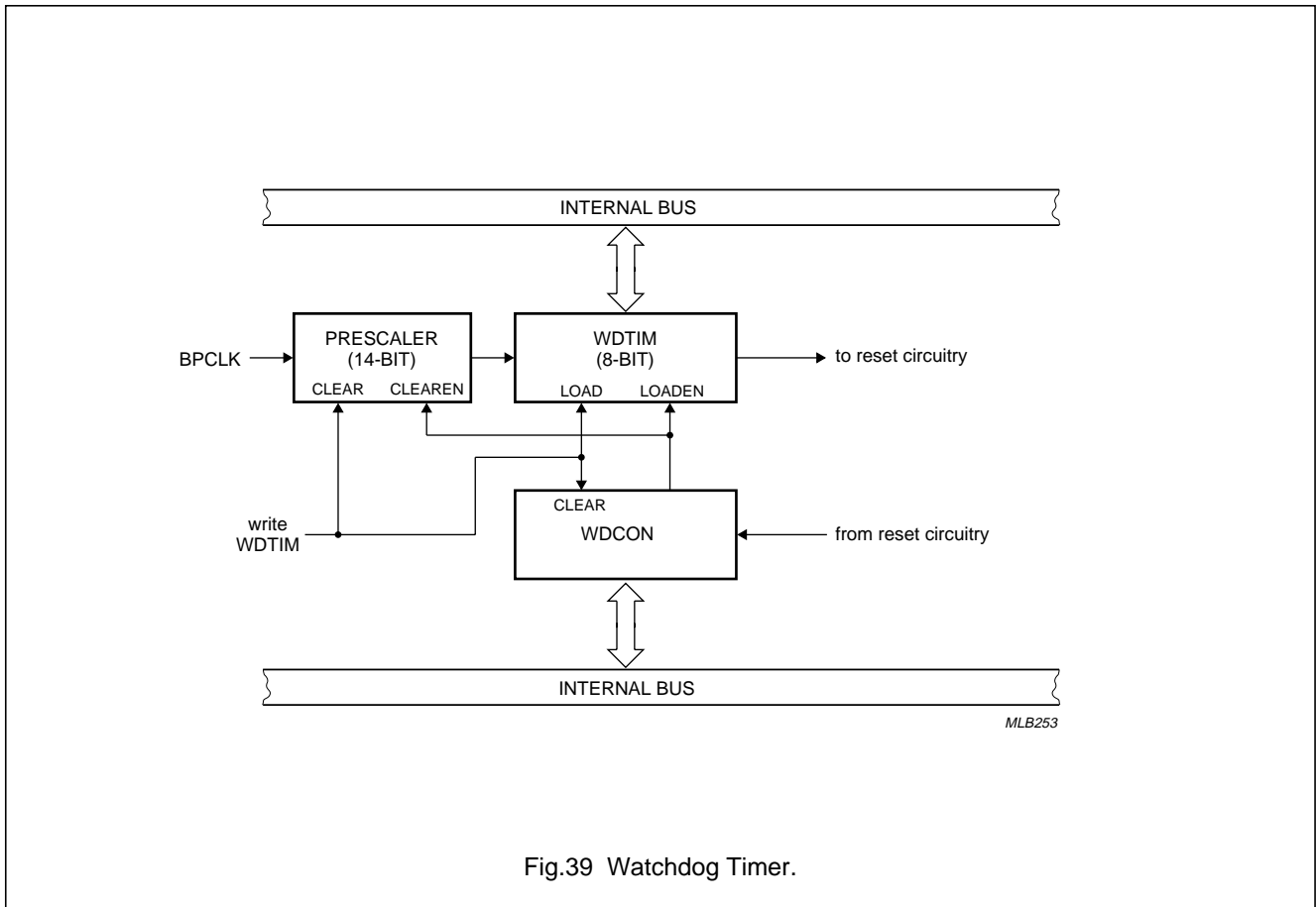

Fig.39 Watchdog Timer.

16-bit microcontroller

P90CE201

13 TIMERS**13.1 General**

The P90CE201 contains three almost identical, fully independent 16-bit timers (T0, T1 and T2). In the following general description of the timer block, “n” represents the number of the Timer (0, 1 or 2).

Timer n is a 16-bit timer/counter which is formed by the two 8-bit registers TLn and THn. Another pair of registers, RCAPLn and RCAPHn, form a 16-bit capture register or a 16-bit reload register. The timers can operate either as a timer or as an event counter. The selection of the clock source for each timer is done in register SYSCON2 (see Table 12). The timers have three operation modes.

- Mode 1: Timer/counter in capture mode
- Mode 2: Timer/counter in auto-reload mode
- mode 3: Timer/counter in baud rate generator mode for UART

The differences between the three timers are listed below:

- Timer 0:** Operates in all modes with the internal frequency of $f_{XTAL}/2$ or $f_{XTAL}/32$. Timer 0 contains a transition detection circuit for the external input. The detection circuitry is controlled by two bits in SYSCON2; all possible transitions can be monitored. Table 47 shows the selection of the trigger pulse.

Table 47 Selection of the trigger pulse.

SYSCON2.3	SYSCON2.2	TRANSITION
0	0	no edge detection
0	1	rising edge detection
1	0	falling edge detection (default value)
1	1	falling and rising edge detection

- Timer 1:** Operates in all modes with the internal frequency of $f_{XTAL}/2$ or $f_{XTAL}/32$. Transition detection for the external input is fixed to falling edge detection.
- Timer 2:** Operates in all modes with the internal frequency of $f_{XTAL}/2$ or $BPCLK/4$. Transition detection for the external input is fixed to falling edge detection.

13.2 Timer operating modes

The Timer Control Register (TnCON) controls the selection of the timer operating modes; this is described in section 13.3.1 Timer Control Register (TnCON).

13.2.1 CAPTURE MODE

In the Capture mode there are two options which are selected by the EXENn bit in TnCON. If EXENn = 0, then Timer n is a 16-bit timer/counter which on overflow sets the Overflow bit TFn. The overflow can be used to generate an interrupt. If EXENn = 1, then Timer n operates in the same way as EXENn = 0 but with the additional feature that a valid transition at the external input Tn causes the current value in Timer n registers (TLn and THn) to be captured into registers RCAPLn and RCAPHn, respectively. The transition at input Tn also causes the EXFn bit in TnCON to be set; this can also be used to generate an interrupt.

13.2.2 AUTO-RELOAD MODE

In the Auto-reload mode there are two options which are selected by the EXENn bit in TnCON. If EXENn = 0, then a Timer n overflow sets the TFn bit and causes the Timer n registers to be reloaded with the 16-bit value held in registers RCAPLn and RCAPHn. This 16-bit value is preset by software. The overflow can be used to generate an interrupt. If EXENn = 1, then Timer n operates as above but with the additional feature that a valid transition at the external input Tn triggers the 16-bit reload and sets the EXFn bit. The transition can also be used to generate an interrupt.

13.2.3 BAUD RATE GENERATOR MODE

The baud rate generator mode for the UART is selected by RCLKn and/or TCLKn in TnCON. Overflows of Timer n can be used for generating baud rates for transmit and receive of the UART in its Modes 1 and 3. See Table 50. The baud rate generation mode is similar to the auto-reload mode, in that a rollover in THn causes the Timer n registers to be reloaded with the 16-bit value held in registers RCAPLn and RCAPHn, which are preset by software. The baud rate for the UART is determined by Timer n's overflow rate as specified below.

$$\text{Baud rate} = \frac{\text{Timer n overflow rate}}{16}$$

16-bit microcontroller

P90CE201

Timer n can be configured for either timer or counter operation. In timer operation the internal timer frequency (f_{INT}) is given by $f_{XTAL}/2$, $f_{XTAL}/32$ or $BPCLK/4$. The baud rate may be calculated as follows:

$$\text{Baud rate} = \frac{f_{INT}}{16 \times (65536 - (RCAPnH, RCAPnL))}$$

In this mode an overflow of Timer n does not set TFn and does not generate an interrupt. If $EXENn = 1$, a valid transition at input pin Tn sets $EXFn$ and can be used to generate an interrupt.

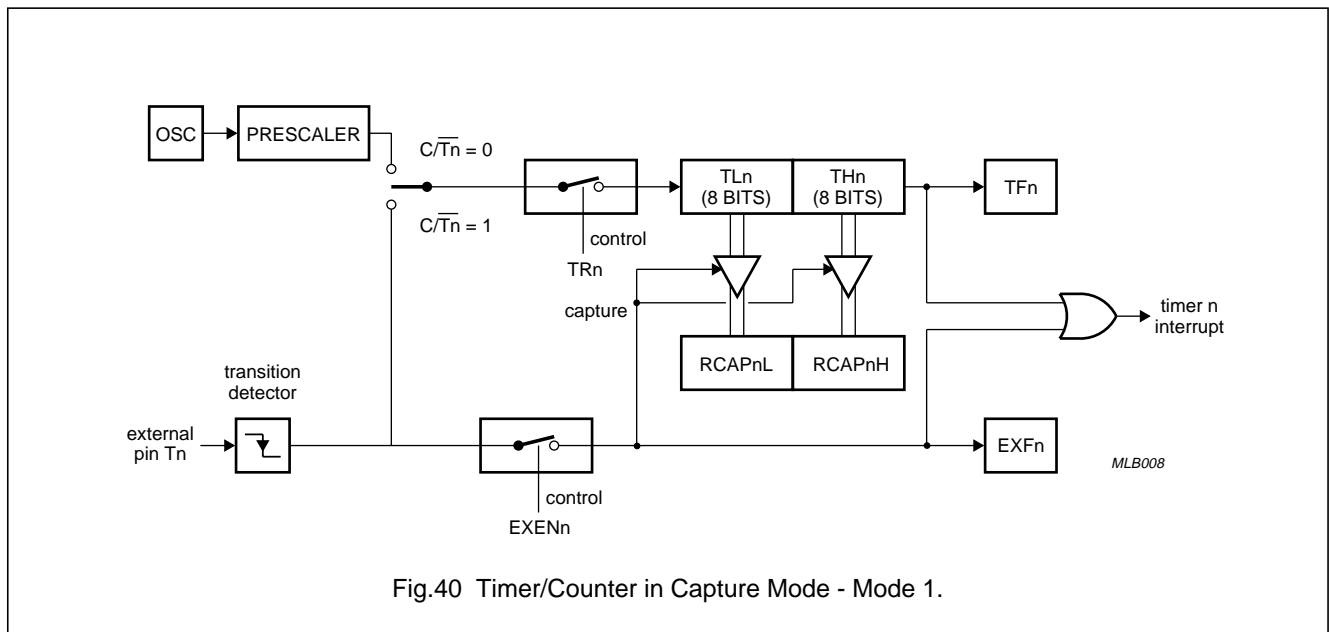

16-bit microcontroller

P90CE201

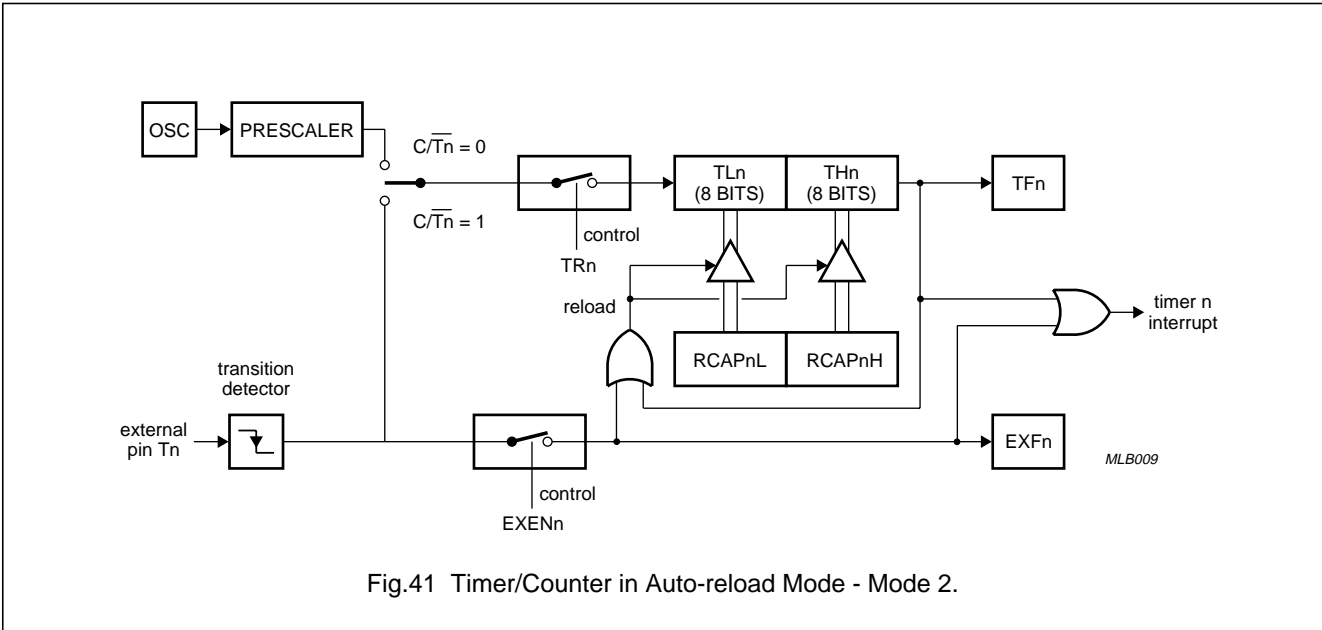

Fig.41 Timer/Counter in Auto-reload Mode - Mode 2.

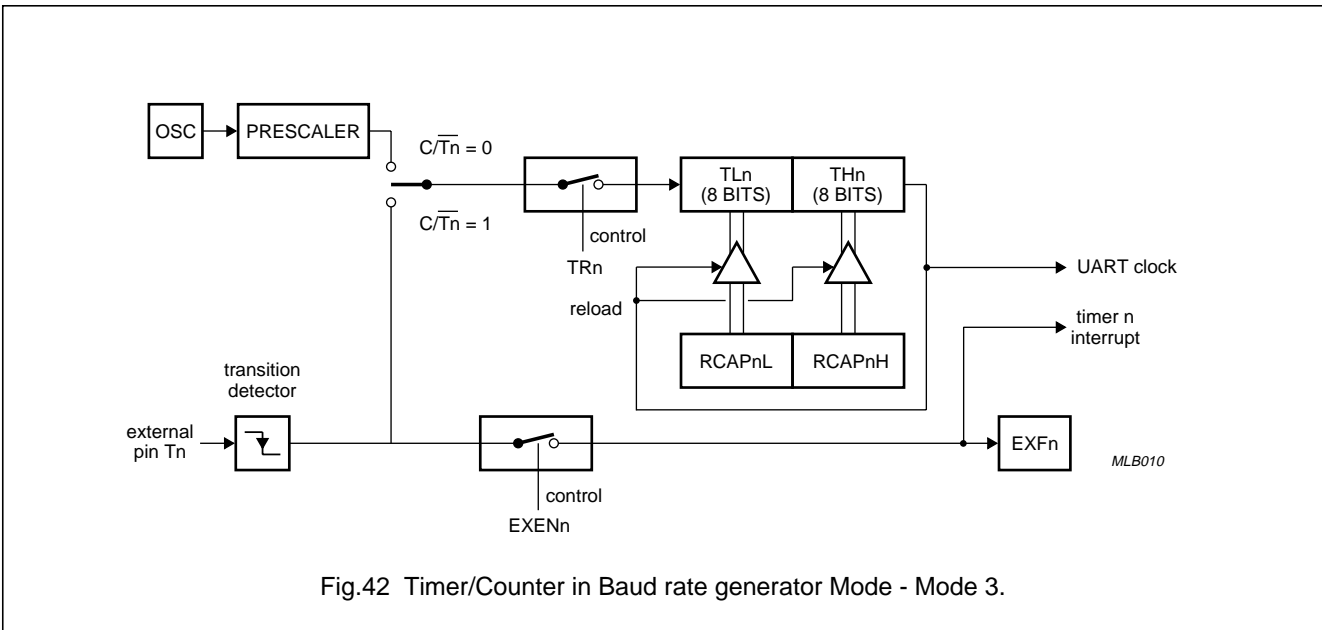

Fig.42 Timer/Counter in Baud rate generator Mode - Mode 3.

16-bit microcontroller

P90CE201

13.3 Timer registers

13.3.1 TIMER CONTROL REGISTER (TnCON)

The Timer Control Register (TnCON) controls the selection of the timer operating modes and the UART clock source.

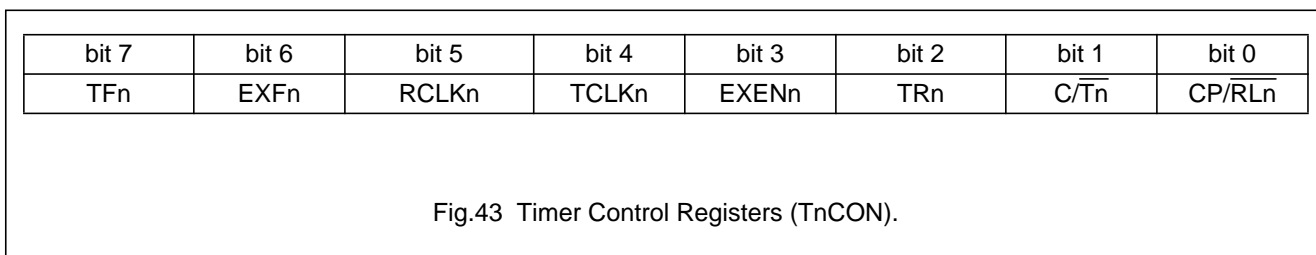

Table 48 Description of TnCON bits.

SYMBOL	BIT	FUNCTION
TFn	TnCON.7	Timer n overflow flag. Set by a Timer n overflow and must be cleared by software. TFn will not be set when either RCLKn = 1 or TCLKn = 1.
EXFn	TnCON.6	Timer n external flag. Set when either a capture or reload is caused by a negative transition on external input Tn and when EXENn = 1. EXFn must be cleared by software.
RCLKn	TnCON.5	Receive Clock flag. When set, causes the UART to use Timer n overflow pulses for its receive clock in Modes 1 and 3. See Table 50.
TCLKn	TnCON.4	Transmit Clock flag. When set, causes the UART to use Timer n overflow pulses for its transmit clock in Modes 1 and 3. See Table 50.
EXENn	TnCON.3	Timer n external enable flag. When set, allows a capture or reload to occur as a result of a negative transition on external input Tn, if Timer n is not being used to clock the UART. EXENn = 0 causes Timer 2 to ignore events at external input Tn.
TRn	TnCON.2	Start/Stop control. TRn = 1 starts Timer n; TRn = 0 stops the timer.
C/Tn	TnCON.1	Timer or Counter select. C/Tn = 0 selects the internal timer. C/Tn = 1 selects the external event counter (edge triggered).
CP/RLn	TnCON.0	Capture/Reload flag. When set, captures will occur on valid transitions at external input Tn, if EXEn2 = 1. When cleared, auto-reloads will occur upon either Timer n overflows or valid transitions at Tn, if EXENn = 1. When either RCLKn = 1 or TCLKn = 1, this bit is ignored and the timer is forced to auto-reload on a Timer n overflow.

16-bit microcontroller

P90CE201

Table 49 Selection of Timer n operating modes.

RCLKn + TCLKn	CP/ \overline{RLn}	TRn	MODE
0	0	1	16-bit automatic reload
0	1	1	16-bit capture
1	X	1	Baud rate generator
X	X	0	off

Table 50 UART clock source for Receive and Transmit - Modes 1 and 3.

RCLK2	RCLK1	RCLK0	UART CLOCK SOURCE
TCLK2	TCLK1	TCLK0	
0	0	0	None
0	0	1	Timer 0
0	1	0	Timer 1
1	0	0	Timer 2
X	1	1	Not usable, see note 1
1	X	1	Not usable, see note 1
1	1	X	Not usable, see note 1

Note

1. These combinations lead to the addition of clock pulses from different timers giving an irregular baud rate clock and therefore should not be used.

16-bit microcontroller

P90CE201

13.3.2 TIMER INTERRUPT REGISTER (TnIR)

Each Timer contains a register for the control of interrupts.

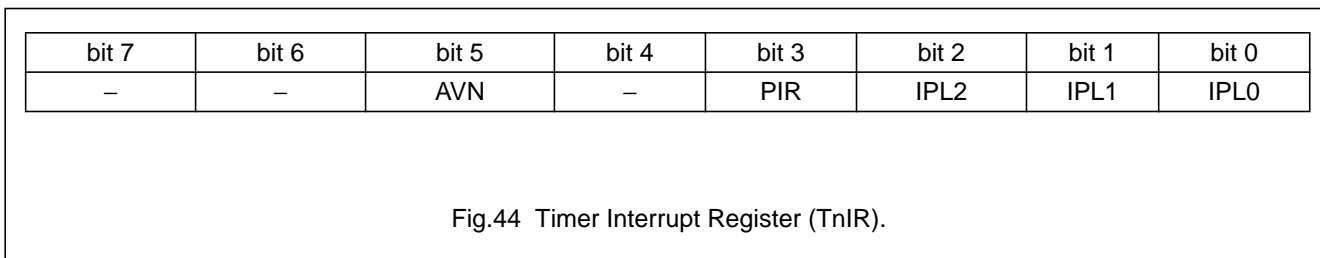

Table 51 Description of TnIR bits.

SYMBOL	BIT	FUNCTION
–	TnIR.7	Reserved
–	TnIR.6	Reserved
AVN	TnIR.5	Autovector. When AVN = 0; the timer interrupt is an autovectored interrupt and the processor calculates the appropriate vector from a fixed vector table. AVN = 0 is also the default value. When AVN = 1; the timer interrupt is a vectored interrupt and the peripheral must provide an 8-bit vectored interrupt.
–	TnIR.4	Reserved
PIR	TnIR.3	Pending Interrupt Request. This bit is set to a logic 1 when a valid interrupt request has been detected. It is automatically reset by the interrupt acknowledge cycle from the CPU. If PIR = 0, there is no pending interrupt request; this is also the default value. The PIR bit can be reset by software by writing a logic 0 to this location.
IPL2 IPL1 IPL0	TnIR.2 TnIR.1 TnIR.0	Interrupt Priority Level. These three bits determine the interrupt priority level of the interrupt requested by the timer. See Table 52.

Table 52 Selection of interrupt priority level.

IPL2	IPL1	IPL0	PRIORITY LEVEL
0	0	0	Interrupt inhibited; this is also the default value.
0	0	1	Level 1
0	1	0	Level 2
0	1	1	Level 3
1	0	0	Level 4
1	0	1	Level 5
1	1	0	Level 6
1	1	1	Level 7

16-bit microcontroller

P90CE201

13.3.3 TIMER INTERRUPT VECTOR (TnIV)

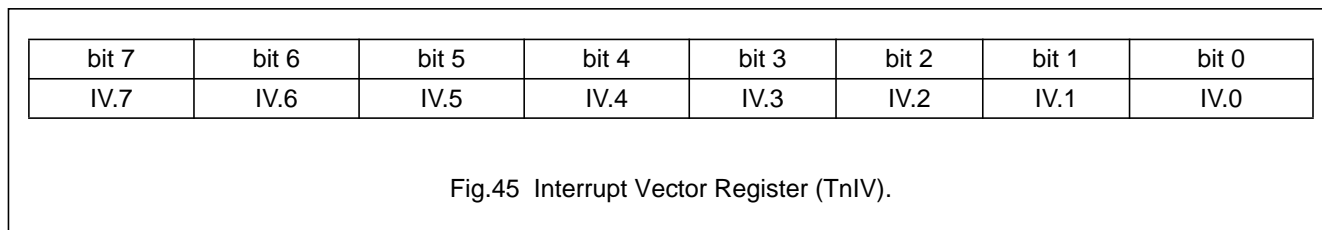
**Table 53** Description of TnIV bits.

SYMBOL	BIT	FUNCTION
IV.7 to IV.0	TnIV.7 to TnIV.0	8-bit interrupt vector number. The default value of this register is 0FH.

16-bit microcontroller

P90CE201

14 ELECTROMAGNETIC COMPATIBILITY (EMC) IMPROVEMENTS

Primary attention has been paid to the reduction of electromagnetic emission of the microcontroller. The following features result in a reduction of the electromagnetic emission and additionally improve the electromagnetic susceptibility:

- Two supply voltage pins (V_{DD1} and V_{DD2}) and two ground pins (V_{SS1} and V_{SS2}) are provided. V_{DD1} and V_{SS1} are adjacent pins located on one side of the package; V_{DD2} and V_{SS2} are also adjacent pins located diagonally opposite the V_{DD1} and V_{SS1} pins.
- Separate power supply pins for internal logic/memory interface and peripheral pins (quiet port)
- Internal decoupling capacitance improves the EMC radiation behaviour and the EMC immunity
- External capacitors are to be connected as close as possible between pins V_{DD1} and V_{SS1} and also V_{DD2} and V_{SS2} . Ceramic chip capacitors are recommended (100 nF).

15 ELECTRICAL SPECIFICATIONS**15.1 Limiting values**

In accordance with the Absolute Maximum Rating System (IEC 134).

SYMBOL	PARAMETER	MIN.	MAX.	UNIT
V_{DD}	supply voltage	-0.5	+6.5	V
V_I	input voltage on any pin with respect to ground (V_{SS})	-0.5	$V_{DD} + 0.5$	V
P_{tot}	total power dissipation; see note 1	-	0.75	W
T_{stg}	storage temperature	-65	+150	°C
T_{amb}	operating ambient temperature	-25	+85	°C

Note

1. This value is based on the maximum allowable die temperature and the thermal resistance of the package; not on device power consumption.

16-bit microcontroller

P90CE201

15.2 DC Characteristics

$V_{DD} = 5\text{ V} \pm 10\%$; $V_{SS} = 0\text{ V}$; $T_{amb} = -25\text{ to }+85\text{ }^{\circ}\text{C}$; all voltages with respect to V_{SS} unless otherwise specified.

SYMBOL	PARAMETER	CONDITIONS	MIN.	MAX.	UNIT
Supply					
V_{DD}	supply voltage		4.5	5.5	V
I_{DD}	supply current operating	$V_{DD} = 5.5\text{ V}$; $f_{CLK} = 24\text{ MHz}$ note 1	–	70	mA
R_{RST}	RESET pull-down resistor		50	150	k Ω
Inputs					
V_{IL}	LOW level input voltage (except SCLn and SDAn)		–0.5	0.8	V
V_{IL1}	LOW level input voltage SCLn and SDAn	note 2	–0.5	1.5	V
V_{IH}	HIGH level input voltage (except RESET, XTAL1, SCLn, SDAn)		2.0	$V_{DD} + 0.5$	V
V_{IH1}	HIGH level input voltage RESET, XTAL1		$0.7V_{DD} + 0.1$	$V_{DD} + 0.5$	V
V_{IH2}	HIGH level input voltage SCLn, SDAn	note 2	3.0	6.0	V
I_{IL}	LOW level input current GP0-5, A16-23 in port mode, INTN0 - 7	$V_{IN} = 0.45\text{ V}$	–	–50	μA
I_{TL}	input current HIGH-to-LOW transition for externally driven port pins (except GP6 and GP7)	$V_{IN} = 2.0\text{ V}$	–	–650	μA
I_{LI}	input leakage current D0 to D7	$0.45\text{ V} \leq V_{IN} \leq V_{DD}$	–	± 10	μA
I_{LI1}	input leakage current SCLn, SDAn	$0.4\text{ V} \leq V_{IN} \leq 4.95\text{ V}$ note 2	–	± 10	μA
Outputs					
V_{OL}	LOW level output voltage (except GP0-3, SCLn,SDAn)	$I_{OL} = 1.6\text{ mA}$; note 3	–	0.45	V
V_{OL1}	LOW level output voltage GP0-3	$I_{OL} = 6.4\text{ mA}$; note 3 $I_{IOL} = 20\text{ mA}$; note 3	–	0.45 1.2	V V
V_{OL2}	LOW level output voltage SCLn, SDAn	$I_{OL} = 3.0\text{ mA}$; notes 2 and 3 $I_{OL} = 60\text{ mA}$; notes 2 and 3	– –	0.4 0.6	V V
V_{OH}	HIGH level output voltage (except SCLn,SDAn)	$I_{OH} = -60\text{ }\mu\text{A}$	2.4	–	V

16-bit microcontroller

P90CE201

Notes

1. The operating supply current is measured during the STOP instruction executed immediately after RESET. All inputs are driven HIGH and outputs are loaded with $C_L = 50 \text{ pF}$, $R = 1 \text{ M}\Omega$; XTAL1 is driven with $t_r = t_f = 5 \text{ ns}$; $V_{IL} = V_{SS} + 0.5 \text{ V}$; $V_{IH1} = V_{DD} - 0.5 \text{ V}$; XTAL2 not connected.
2. The parameter meets the I²C-bus specification for standard mode and fast mode devices.
3. Under steady state (non-transient) conditions, I_{OL} must be externally limited as shown in Table 54. If I_{OL} exceeds the test conditions, V_{OL} may exceed the related specification. Pins are not guaranteed to sink current greater than the listed test conditions.

Table 54 Maximum I_{OL} values.

PARAMETER	MAX	UNIT
Maximum I_{OL} per port pin	10	mA
Maximum I_{OL} per high drive port pin (GP0 - GP3)	20	mA
Maximum total I_{OL} for all output pins	100	mA

15.3 AC Characteristics

$V_{DD} = 5 \text{ V} \pm 10\%$; $V_{SS} = 0 \text{ V}$; $T_{CLCLmin} = 1/f_{CLKmax} = 42 \text{ ns}$; $T_{amb} = -25 \text{ to } +85 \text{ }^\circ\text{C}$.

15.3.1 AC TESTING INPUT AND OUTPUT WAVEFORMS.

AC test inputs are driven at 2.4 V for a logic 1 and 0.45 V for a logic 0. Timing measurements are taken at 2.0 V for a logic 1 and 0.8 V for a logic 0. See Fig.46(a).

The float state is defined as the point at which the pin sinks 3.2 mA or sources 400 μA at the voltage test levels. See Fig.46(b).

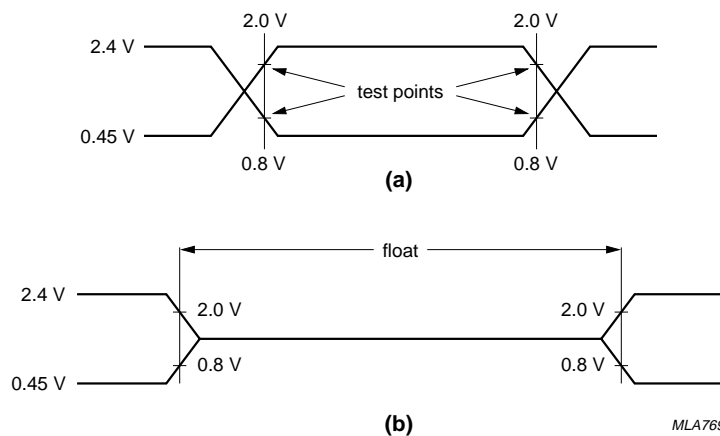

Fig.46 AC testing input, output waveform (a) and float waveform (b).

16-bit microcontroller

P90CE201

15.3.2 EXTERNAL CLOCK DRIVE XTAL1

Table 55 External clock drive XTAL1.

SYMBOL	PARAMETER	MIN.	MAX.	UNIT
t_{CLCL}	clock period	42	250	ns
t_{CHCX}	HIGH time	15	$t_{CLCL} - t_{CLCX}$	ns
t_{CLCX}	LOW time	15	$t_{CLCL} - t_{CHCX}$	ns
t_{CLCH}	rise time	–	20	ns
t_{CHCL}	fall time	–	20	ns

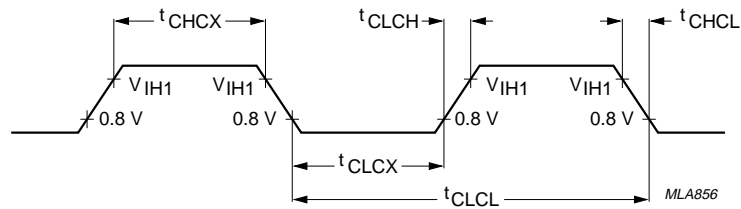

Fig.47 External clock drive XTAL1.

16-bit microcontroller

P90CE201

15.3.3 EXTERNAL MEMORY INTERFACE

Table 56 External memory read cycle timing.

SYMBOL	PARAMETER	MIN.	MAX.	UNIT
t_{AVSL}	address valid to CSROMN/CSRAMN LOW	$t_{CLCL} - 25$	–	ns
t_{SLDV}	CSROMN/CSRAMN LOW to data valid; note 1	–	$(2 + WS/2)t_{CLCL} - 65$	ns
t_{AXDX}	address invalid to data invalid	0	–	ns
t_{AVDV}	address valid to data valid; note 1	–	$(2 + WS/2)t_{CLCL} - 65$	ns
t_{SHAX}	CSROMN/CSRAMN HIGH to address invalid	$t_{CLCL} - 15$	–	ns </td
t_{SHDX}	CSROMN/CSRAMN HIGH to data invalid	0	–	ns

Note

1. WS is the number of additional wait states access time values. See Table 11 in section 6.

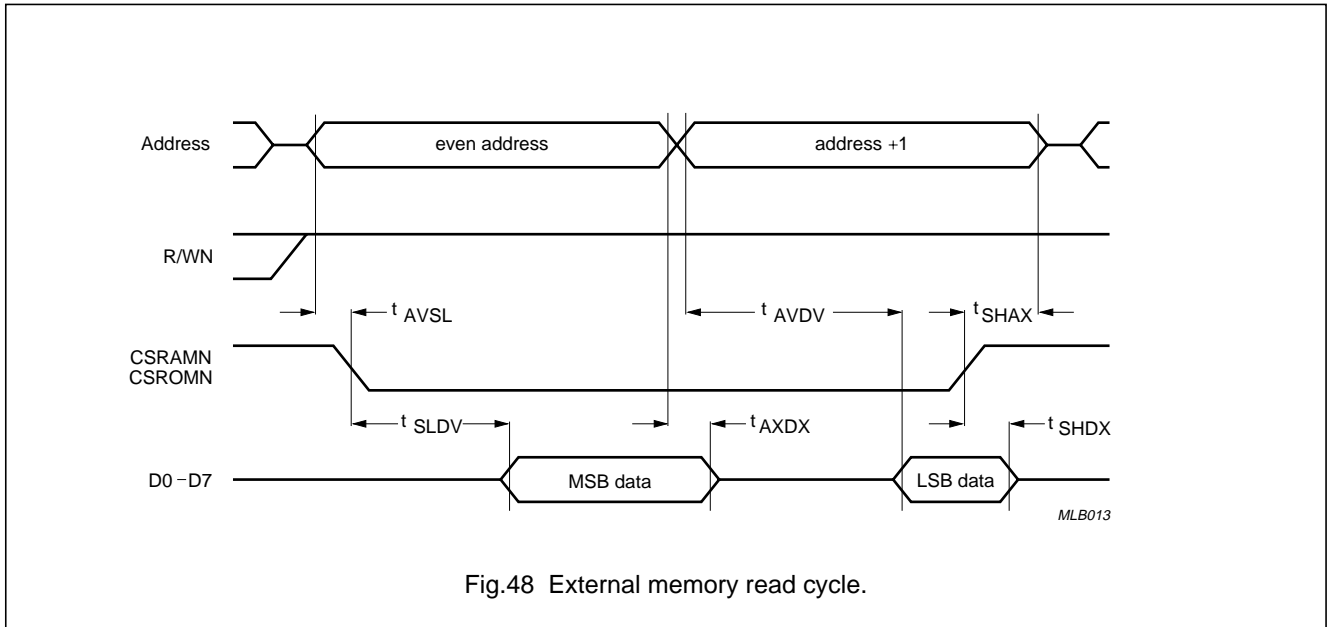

Fig.48 External memory read cycle.

16-bit microcontroller

P90CE201

Table 57 External memory write cycle timing.

SYMBOL	PARAMETER	MIN.	UNIT
t_{AVSL}	address valid to CSROMN/CSRAMN LOW	$t_{CLCL} - 25$	ns
t_{WLSL}	RWN LOW to CSROMN/CSRAMN LOW	$t_{CLCL} - 25$	ns
t_{SHWH}	CSROMN/CSRAMN HIGH to RWN HIGH	$t_{CLCL} - 15$	ns
t_{SLSH}	CSROMN/CSRAMN LOW; note 1	$(2 + WS/2)t_{CLCL} - 15$	ns
t_{SHAX}	CSROMN/CSRAMN HIGH to address invalid	$t_{CLCL} - 15$	ns
t_{QVSH}	data set-up to CSROMN/CSRAMN HIGH; note 1	$(2 + WS/2)t_{CLCL} - 20$	ns
t_{SHQX}	CSROMN/CSRAMN HIGH to data invalid	$t_{CLCL} - 15$	ns

Note

1. WS is the number of additional wait states access time values. See Table 11 in section 6.

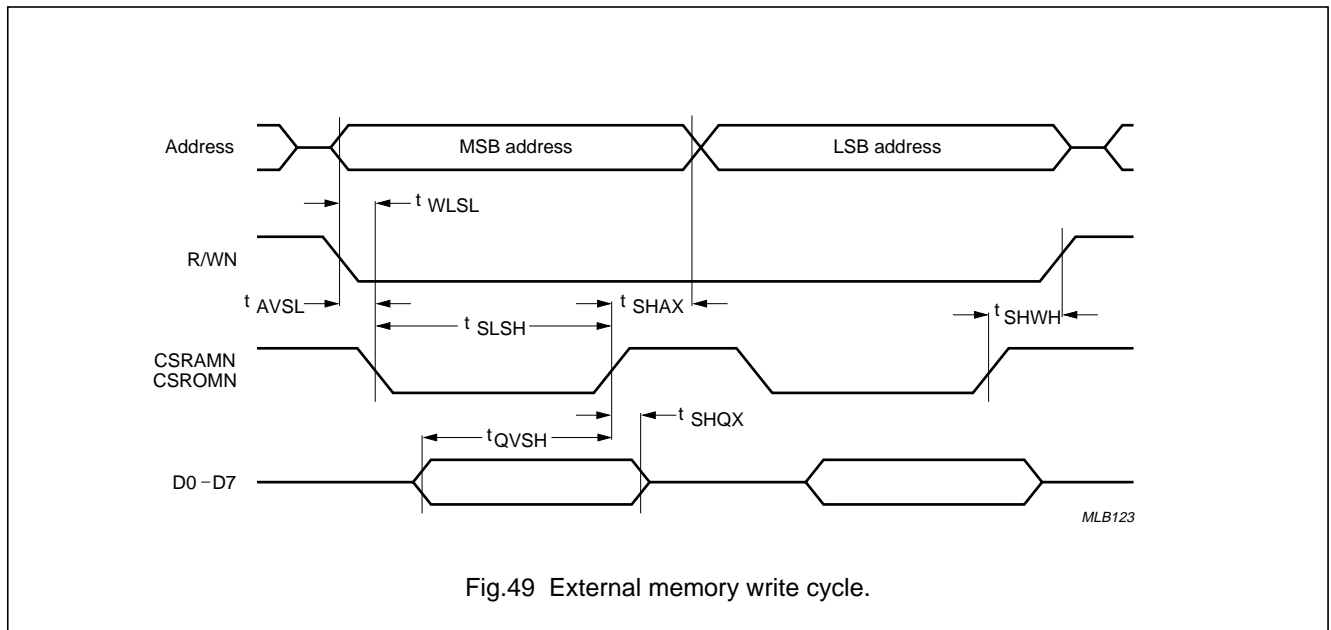

16-bit microcontroller

P90CE201

15.3.4 FAST I²C-BUS TIMING.**Table 58** Fast I²C-bus timing.

SYMBOL	PARAMETER	MIN.	MAX.	UNIT
f _{SCL}	SCL clock frequency	0	400	kHz
t _{BUF}	bus free time between a STOP and START condition	1300	–	ns
t _{HD; STA}	hold time (repeated) START condition	600	–	ns
t _{LOW}	LOW period of the SCL clock	1300	–	ns
t _{HIGH}	HIGH period of the SCL clock	600	–	ns
t _{SU; STA}	set-up time (repeated) START	600	–	ns
t _{HD; DAT}	data hold time (note 1)	0	900	ns
t _{SU; DAT}	data set-up time (note 2)	100	–	ns
t _{RC; t_{RD}}	rise time of both SDA and SCL lines (note 3)	(20 + 0.1Cb)	300	ns
t _{FC; t_{FD}}	fall time of both SDA and SCL lines (note 3)	(20 + 0.1Cb)	300	ns
t _{SU; STO}	set-up time for STOP condition	600	–	ns
C _b	capacitive load of each bus line	–	400	pF

Notes

1. A device must internally provide a hold time of at least 300 ns for the SDA signal, referenced to V_{IHmin} of the SCL signal, in order to bridge the undefined region of the falling edge of SCL. The maximum t_{HD; DAT} has to be met only if the device does not stretch the SCL LOW period (t_{LOW}).
2. A fast-mode I²C-bus device can be used in a “0-to-100 kbit/s” I²C-bus system and then the requirement t_{SU; DAT} > 250 ns must be fulfilled. This will automatically be the case if the device does not stretch the LOW period of the SCL signal. But if such a device stretches the LOW period of the SCL signal, it must output the next data bit to the SDA line (t_{RDmax} + t_{SU; DAT}) = 1000 + 250 = 1250 ns before the SCL line is released according to the existing “0-to-100 kbit/s” I²C-bus specification.
3. C_b = Total capacitance value of one bus line in pF.

16-bit microcontroller

P90CE201

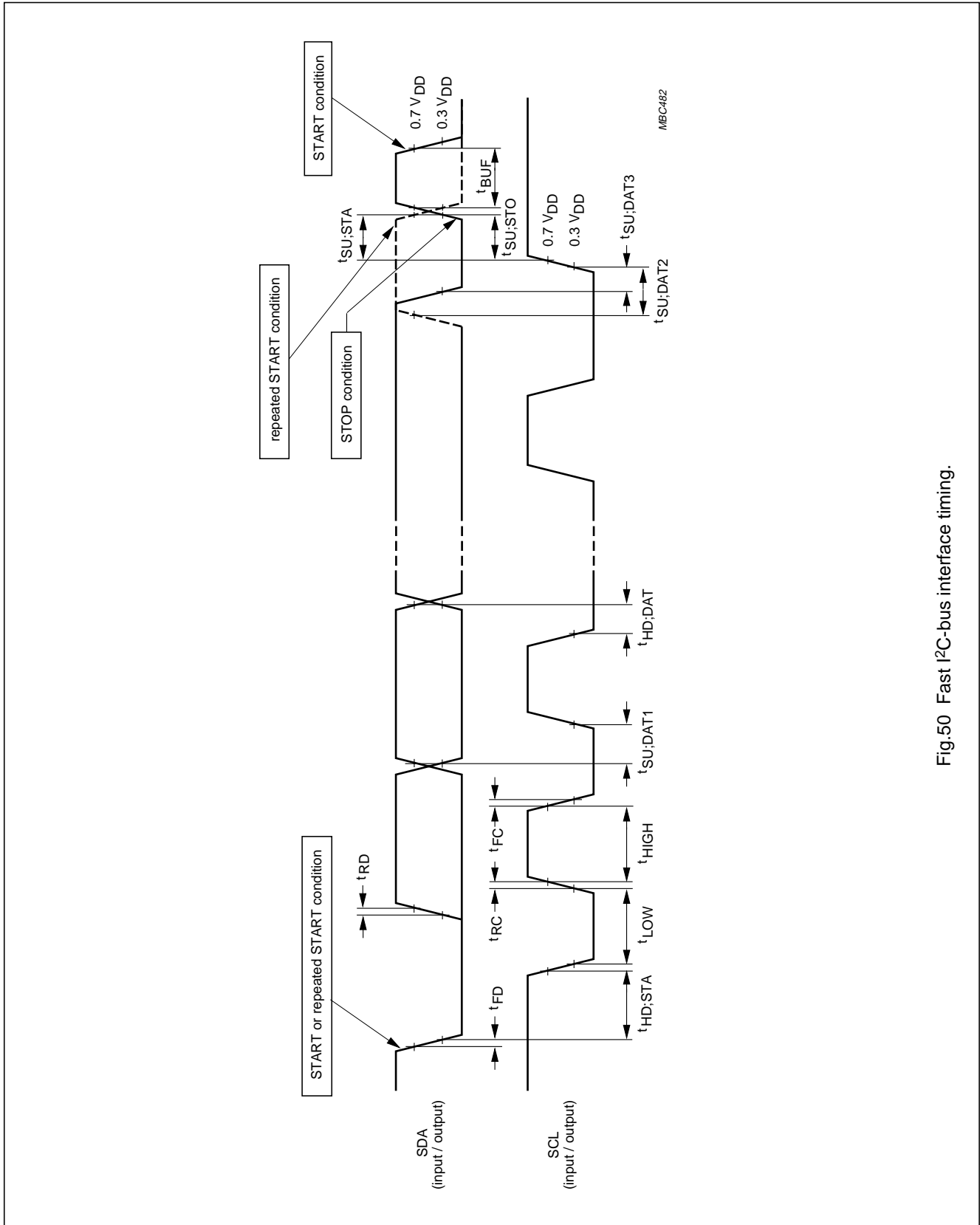

Fig.50 Fast I²C-bus interface timing.

16-bit microcontroller

P90CE201

15.3.5 UART SHIFT REGISTER MODE TIMING

Table 59 Basic peripheral clock set to 4 MHz; $C_L = 80$ pF.

SYMBOL	PARAMETER	MIN.	MAX.	UNIT
t_{XLXL}	serial port clock cycle time	1000	–	ns
t_{QVXH}	output data set-up to clock rising edge	700	–	ns
t_{XHQX}	output data hold after clock rising edge	50	–	ns
t_{XHDX}	input data hold after clock rising edge	0	–	ns
t_{XHDV}	clock rising edge to input data valid	–	700	ns

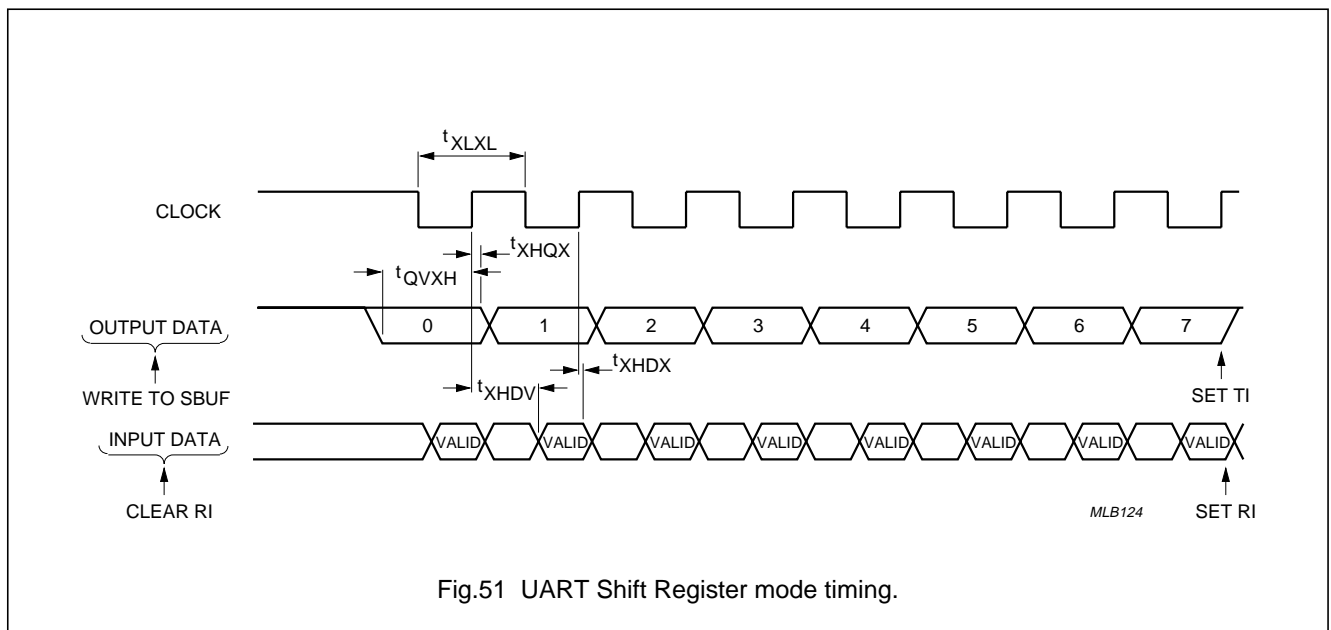

Fig.51 UART Shift Register mode timing.

16-bit microcontroller

P90CE201

16 REGISTER MAP

The internal register map of the P90CE201 is summarized in the following tables.

ADDRESS (HEX)	SYMBOL		REGISTER	
System registers				
8000 1000	SYSCON1H	SYSCON1	System Control Register 1 High	R/W
8000 1001	SYSCON1L		System Control Register 1 Low	R/W
8000 1002	SYSCON2H	SYSCON2	System Control Register 2 High	R/W
8000 1003	SYSCON1L		System Control Register 2 Low	R/W
8000 1004 to 800 101F			Reserved	
Interrupt registers				
8000 1020			Reserved	
8000 1021	LIR7		Latched Interrupt 7 Register	R/W
8000 1022			Reserved	
8000 1023	LIV7		Latched Interrupt 7 vector	R/W
8000 1024			Reserved	
8000 1025	LIR6		Latched Interrupt 6 Register	R/W
8000 1026			Reserved	
8000 1027	LIV6		Latched Interrupt 6 vector	R/W
8000 1028			Reserved	
8000 1029	LIR5		Latched Interrupt 5 Register	R/W
8000 102A			Reserved	
8000 102B	LIV5		Latched Interrupt 5 vector	R/W
8000 102C			Reserved	
8000 102D	LIR4		Latched Interrupt 4 Register	R/W
8000 102E			Reserved	
8000 102F	LIV4		Latched Interrupt 4 vector	R/W
8000 1030			Reserved	
8000 1031	LPCRH		Port Control Register bit 7 to 4	R/W
8000 1032			Reserved	
8000 1033	LPPH		Port Pad/Control Register bit 7 to 4	R/W
8000 1034 to 8000 1040			Reserved	
8000 1041	LIR3		Latched Interrupt 3 Register	R/W
8000 1042			Reserved	
8000 1043	LIV3		Latched Interrupt 3 vector	R/W
8000 1044			Reserved	
8000 1045	LIR2		Latched Interrupt 2 Register	R/W
8000 1046			Reserved	
8000 1047	LIV2		Latched Interrupt 2 vector	R/W

16-bit microcontroller

P90CE201

ADDRESS (HEX)	SYMBOL	REGISTER	
8000 1048		Reserved	
8000 1049	LIR1	Latched Interrupt 1 Register	R/W
8000 104A		Reserved	
8000 104B	LIV1	Latched Interrupt 1 vector	R/W
8000 104C		Reserved	
8000 104D	LIR0	Latched Interrupt 0 Register	R/W
8000 104E		Reserved	
8000 104F	LIV0	Latched Interrupt 0 vector	R/W
8000 1050		Reserved	
8000 1051	LPCRL	Port Control Register bit 3 to 0	R/W
8000 1052		Reserved	
8000 1053	LPPL	Port Pad/Control Register bit 3 to 0	R/W
8000 1054 to 8000 105F		Reserved	
I²C Registers			
8000 2000		Reserved	
8000 2001	S1DAT	I ² C1 Data Register	R/W
8000 2002		Reserved	
8000 2003	S1ADR	I ² C1 Address Register	R/W
8000 2004		Reserved	
8000 2005	S1STA	I ² C1 Status Register	R
8000 2006		Reserved	
8000 2007	S1CON	I ² C1 Control Register	R/W
8000 2008		Reserved	
8000 2009	S1IR	I ² C1 Interrupt Register	R/W
8000 200A		Reserved	
8000 200B	S1IV	I ² C1 Interrupt vector	R/W
8000 200C to 8000 2010		Reserved	
8000 2011	S2DAT	I ² C2 Data Register	R/W
8000 2012		Reserved	
8000 2013	S2ADR	I ² C2 Address Register	R/W
8000 2014		Reserved	
8000 2015	S2STA	I ² C2 Status Register	R
8000 2016		Reserved	
8000 2017	S2CON	I ² C2 Control Register	R/W
8000 2018		Reserved	
8000 2019	S2IR	I ² C2 Interrupt Register	R/W
8000 201A		Reserved	
8000 201B	S2IV	I ² C2 Interrupt vector	R/W
8000 201C to 8000 201F		Reserved	

16-bit microcontroller

P90CE201

ADDRESS (HEX)	SYMBOL		REGISTER	
UART registers				
8000 2020			Reserved	
8000 2021	SBUF		UART Transmit/Receive Register	R/W
8000 2022			Reserved	
8000 2023	SCON		UART Control Register	R/W
8000 2024			Reserved	
8000 2025	URIR		UART Receiver Interrupt Register	R/W
8000 2026			Reserved	
8000 2027	URIV		UART Receiver Interrupt vector	R/W
8000 2028			Reserved	
8000 2029	UTIR		UART Transmitter Interrupt Register	R/W
8000 202A			Reserved	
8000 202B	UTIV		UART Transmitter Interrupt vector	R/W
8000 202C to 8000 202F			Reserved	
Timers registers				
8000 2030	TH0	T0	Timer 0 High Order Register	R/W
8000 2031	TL0		Timer 0 Low Order Register	R/W
8000 2032	RCAPH0	RCAP0	Timer 0 Reload/Capture High Order Register	R/W
8000 2033	RCAPL0		Timer 0 Reload/Capture Low Order Register	R/W
8000 2034			Reserved	
8000 2035	T0CON		Timer 0 Control Register	R/W
8000 2036			Reserved	
8000 2037	T0IR		Timer 0 Interrupt Register	R/W
8000 2038			Reserved	
8000 2039	T0IV		Timer 0 Interrupt vector	R/W
8000 203A to 800 203F			Reserved	
8000 2040	TH1	T1	Timer 1 High Order Register	R/W
8000 2041	TL0		Timer 1 Low Order Register	R/W
8000 2042	RCAPH1	RCAP1	Timer 1 Reload/Capture High Order Register	R/W
8000 2043	RCAPL1		Timer 1 Reload/Capture Low Order Register	R/W
8000 2044			Reserved	
8000 2045	T1CON		Timer 1 Control Register	R/W
8000 2046			Reserved	
8000 2047	T1IR		Timer 1 Interrupt Register	R/W
8000 2048			Reserved	
8000 2049	T1IV		Timer 1 Interrupt vector	R/W
8000 204A to 8000 204F			Reserved	
8000 2050	TH2	T2	Timer 2 High Order Register	R/W
8000 2051	TL2		Timer 2 Low Order Register	R/W

16-bit microcontroller

P90CE201

ADDRESS (HEX)	SYMBOL		REGISTER	
8000 2052	RCAPH2	RCAP2	Timer 2 Reload/Capture Low Order Register	R/W
8000 2053	RCAPL2		Timer 2 Reload/Capture Low Order Register	R/W
8000 2054			Reserved	
8000 2055	T2CON		Timer 2 Control Register	R/W
8000 2056			Reserved	
8000 2057	T2IR		Timer 2 Interrupt Register	R/W
8000 2058			Reserved	
8000 2059	T2IV		Timer 2 Interrupt vector	R/W
8000 205A to 8000 205F			Reserved	
Watchdog registers				
8000 2060			Reserved	
8000 2061	WDTIM		Watchdog Timer Register	R/W
8000 2062			Reserved	
8000 2063	WDCON		Watchdog Control Register	R/W
8000 2064 to 8000 206F			Reserved	
General Port registers				
8000 2070			Reserved	
8000 2071	GPP		Port Pad/Register	R/W
8000 2072			Reserved	
8000 2073	GP		Port Register	R/W
8000 2074 to 8000 207F			Reserved	
Auxiliary Port registers				
8000 2080			Reserved	
8000 2081	APP		Auxiliary Port Pad/Register	R/W
8000 2082			Reserved	
8000 2083	APCON		Auxiliary Port Control Register	R/W
8000 2084 to 8000 208F			Reserved	

16-bit microcontroller

P90CE201

17 PACKAGE OUTLINE

QFP64: plastic quad flat package; 64 leads (lead length 1.95 mm); body 14 x 20 x 2.8 mm

SOT319-2

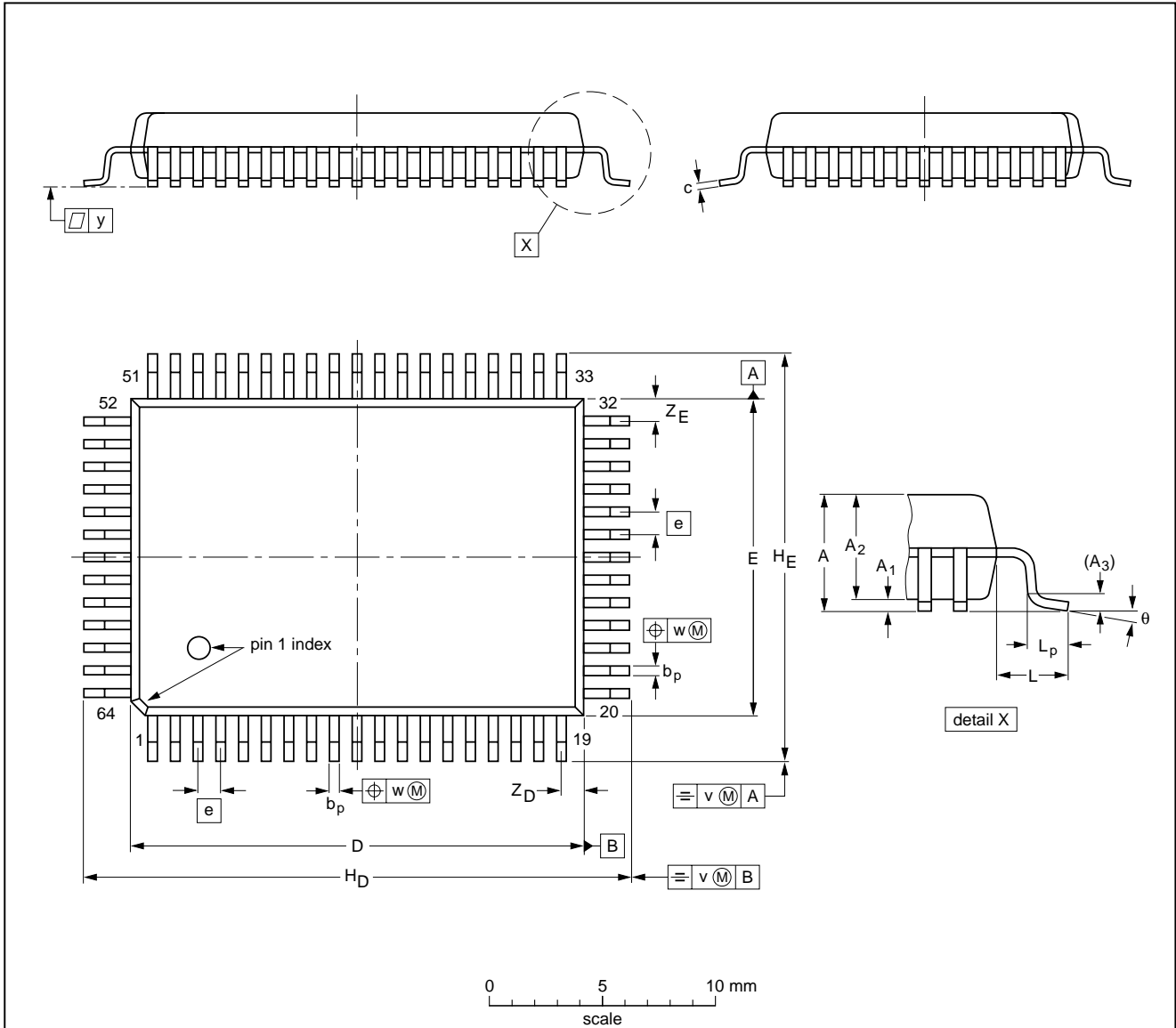

DIMENSIONS (mm are the original dimensions)

UNIT	A max.	A ₁	A ₂	A ₃	b _p	c	D ⁽¹⁾	E ⁽¹⁾	e	H _D	H _E	L	L _p	v	w	y	Z _D ⁽¹⁾	Z _E ⁽¹⁾	θ
mm	3.20	0.25 0.05	2.90 2.65	0.25	0.50 0.35	0.25 0.14	20.1 19.9	14.1 13.9	1	24.2 23.6	18.2 17.6	1.95	1.0 0.6	0.2	0.2	0.1	1.2 0.8	1.2 0.8	7° 0°

Note

1. Plastic or metal protrusions of 0.25 mm maximum per side are not included.

OUTLINE VERSION	REFERENCES				EUROPEAN PROJECTION	ISSUE DATE
	IEC	JEDEC	EIAJ			
SOT319-2						95-02-04 97-08-01

16-bit microcontroller

P90CE201

18 SOLDERING

18.1 Introduction

There is no soldering method that is ideal for all IC packages. Wave soldering is often preferred when through-hole and surface mounted components are mixed on one printed-circuit board. However, wave soldering is not always suitable for surface mounted ICs, or for printed-circuits with high population densities. In these situations reflow soldering is often used.

This text gives a very brief insight to a complex technology. A more in-depth account of soldering ICs can be found in our *"IC Package Databook"* (order code 9398 652 90011).

18.2 Reflow soldering

Reflow soldering techniques are suitable for all QFP packages.

The choice of heating method may be influenced by larger plastic QFP packages (44 leads, or more). If infrared or vapour phase heating is used and the large packages are not absolutely dry (less than 0.1% moisture content by weight), vaporization of the small amount of moisture in them can cause cracking of the plastic body. For more information, refer to the Drypack chapter in our *"Quality Reference Handbook"* (order code 9397 750 00192).

Reflow soldering requires solder paste (a suspension of fine solder particles, flux and binding agent) to be applied to the printed-circuit board by screen printing, stencilling or pressure-syringe dispensing before package placement.

Several techniques exist for reflowing; for example, thermal conduction by heated belt. Dwell times vary between 50 and 300 seconds depending on heating method. Typical reflow temperatures range from 215 to 250 °C.

Preheating is necessary to dry the paste and evaporate the binding agent. Preheating duration: 45 minutes at 45 °C.

18.3 Wave soldering

Wave soldering is **not** recommended for QFP packages. This is because of the likelihood of solder bridging due to closely-spaced leads and the possibility of incomplete solder penetration in multi-lead devices.

If wave soldering cannot be avoided, the following conditions must be observed:

- **A double-wave (a turbulent wave with high upward pressure followed by a smooth laminar wave) soldering technique should be used.**
- **The footprint must be at an angle of 45° to the board direction and must incorporate solder thieves downstream and at the side corners.**

Even with these conditions, do not consider wave soldering the following packages: QFP52 (SOT379-1), QFP100 (SOT317-1), QFP100 (SOT317-2), QFP100 (SOT382-1) or QFP160 (SOT322-1).

During placement and before soldering, the package must be fixed with a droplet of adhesive. The adhesive can be applied by screen printing, pin transfer or syringe dispensing. The package can be soldered after the adhesive is cured.

Maximum permissible solder temperature is 260 °C, and maximum duration of package immersion in solder is 10 seconds, if cooled to less than 150 °C within 6 seconds. Typical dwell time is 4 seconds at 250 °C.

A mildly-activated flux will eliminate the need for removal of corrosive residues in most applications.

18.4 Repairing soldered joints

Fix the component by first soldering two diagonally-opposite end leads. Use only a low voltage soldering iron (less than 24 V) applied to the flat part of the lead. Contact time must be limited to 10 seconds at up to 300 °C. When using a dedicated tool, all other leads can be soldered in one operation within 2 to 5 seconds between 270 and 320 °C.

16-bit microcontroller

P90CE201

19 DEFINITIONS

Data sheet status	
Objective specification	This data sheet contains target or goal specifications for product development.
Preliminary specification	This data sheet contains preliminary data; supplementary data may be published later.
Product specification	This data sheet contains final product specifications.
Limiting values	
Limiting values given are in accordance with the Absolute Maximum Rating System (IEC 134). Stress above one or more of the limiting values may cause permanent damage to the device. These are stress ratings only and operation of the device at these or at any other conditions above those given in the Characteristics sections of the specification is not implied. Exposure to limiting values for extended periods may affect device reliability.	
Application information	
Where application information is given, it is advisory and does not form part of the specification.	

20 LIFE SUPPORT APPLICATIONS

These products are not designed for use in life support appliances, devices, or systems where malfunction of these products can reasonably be expected to result in personal injury. Philips customers using or selling these products for use in such applications do so at their own risk and agree to fully indemnify Philips for any damages resulting from such improper use or sale.

21 PURCHASE OF PHILIPS I²C COMPONENTS

Purchase of Philips I²C components conveys a license under the Philips' I²C patent to use the components in the I²C system provided the system conforms to the I²C specification defined by Philips. This specification can be ordered using the code 9398 393 40011.

This datasheet has been download from:

www.datasheetcatalog.com

Datasheets for electronics components.